

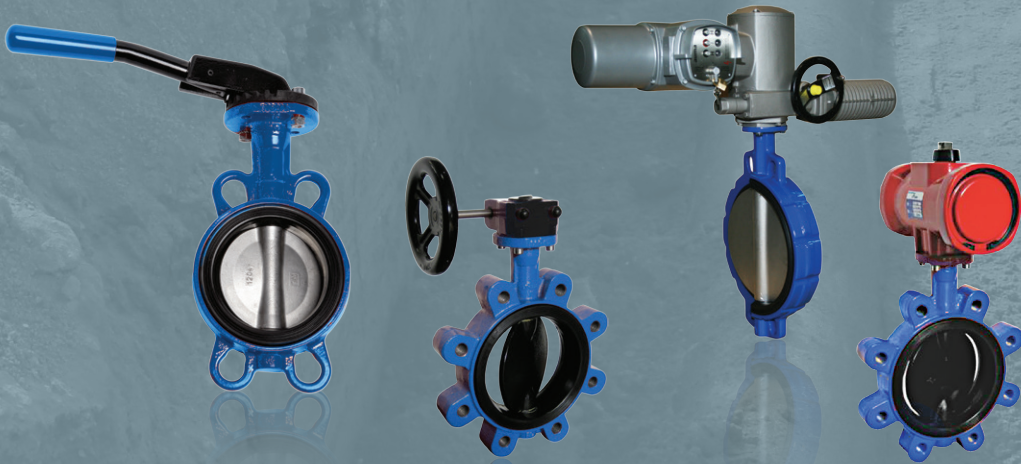

BUTTERFLY VALVES WAFER AND LUG



Comprehensive pipe solutions

PAM
SAINT-GOBAIN



STANDARD RANGE

- Wafer:
 - . DN 40 to 1200 PFA 10/16 bar
 - . DN 40 to 300 PFA 25 bar
- Lug:
 - . DN 40 to 1000 PFA 10/16 bar
 - . DN 40 to 300 PFA 25 bar

Materials and coatings

- Body: ductile iron + RAL 5005 min. 150 µm powder coated epoxy
- Butterfly/disc:
 - . Ductile iron black min. 150 µm powder coated epoxy with ACS
 - . CF8M stainless steel
- Seat: EPDM with ACS

Actuators

- Manual:
 - . MN/MR with handlever DN 40 to 350
 - . Gearbox with handwheel DN40 to 1200
- Motorised:
 - . Electrical AUMA or BERNARD
 - . Pneumatic: spring return or double effect

Accessories

Manual/electric position indicator, solenoid valves, extensions, etc.

Saint-Gobain PAM offers a wide range of coatings and materials to meet diverse requirements.

For more information contact our technical sales department.

FIELD OF USED

- Transport and distribution of drinking and raw water
- Drainage of waste water
- Pumping and hydroelectric plants
- Treatment of drinking water and desalination
- Fire fighting
- Mines
- Naval construction

FLUIDS

- Drinking water
- Waste water
- Raw water with suspended solids
- Sea water

Renowned in the industry sector for its extensive range of materials, coatings and actuators, the short pattern concentric Wafer and Lug Butterfly Valves (BV) are installed overhead where there are many dimensional constraints.

Their wide range of materials and coatings meet all types of application areas such as drinking water, raw water, sea water and gaseous fluids (such as air, gas, etc.) for temperature ranges from -40°C to 95°C.

They provide an effective and reliable solution for the industry, the hydroelectric pumping stations, fire-fighting, irrigation, water treatment, desalination, etc.

For the same diameter, the disk, shaft and seat of the Wafer and Lug are identical and can therefore be interchanged.

Installed between two flanges, only the connectivity and the network maintenance are different.

- Wafer BV:
 - . installed using ties and nuts
 - . can be dissembled under pressure
- Lug BV:
 - . installed with double sided screws without nut
 - . can be dissembled under pressure

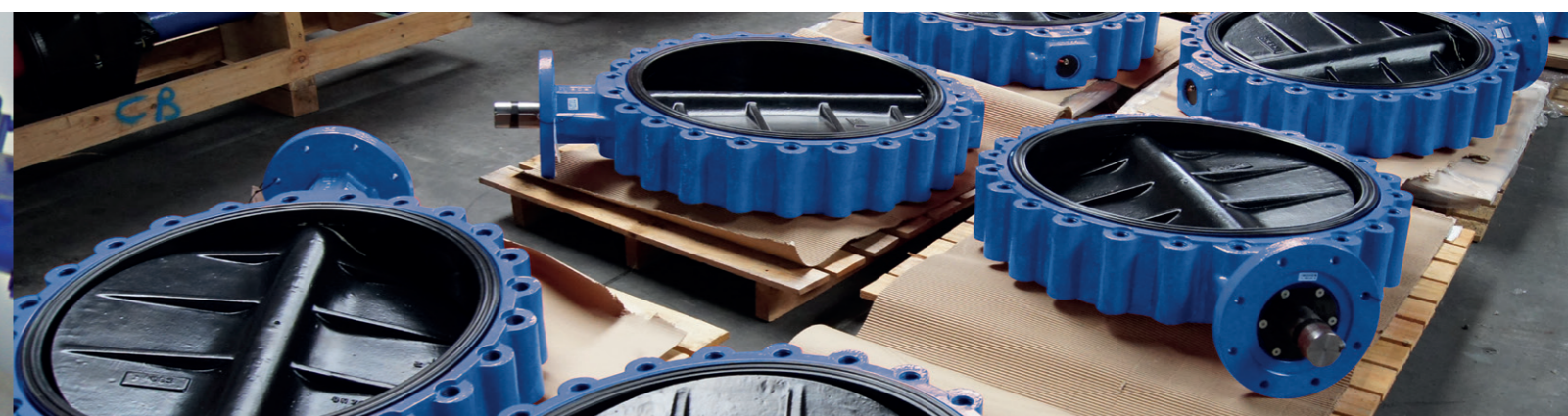
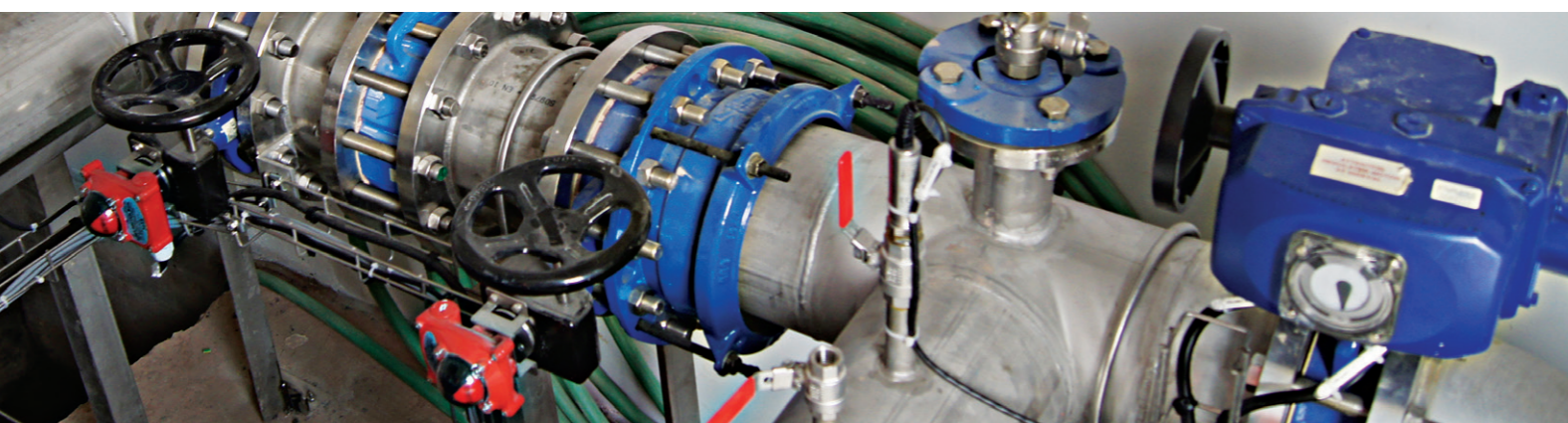
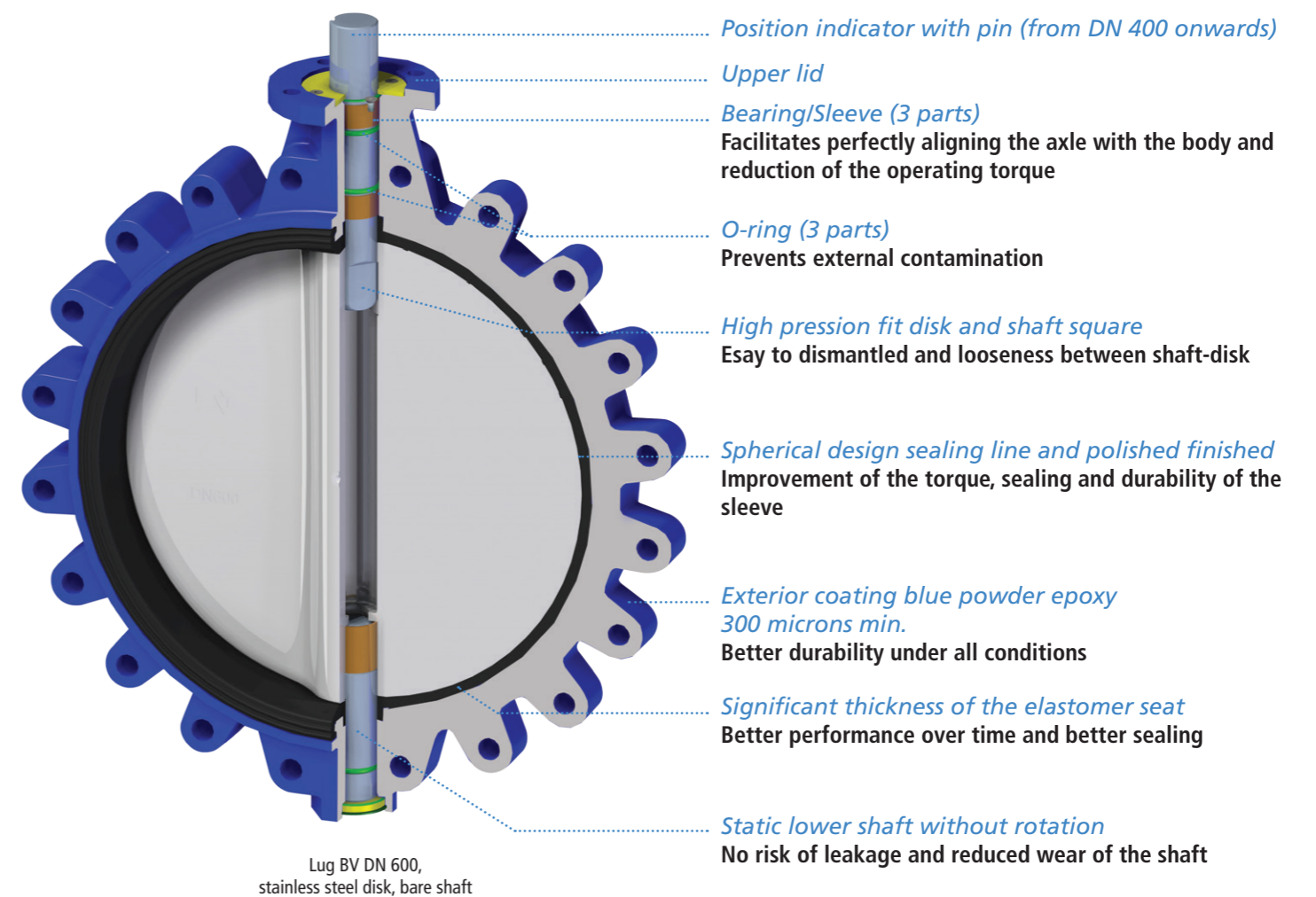
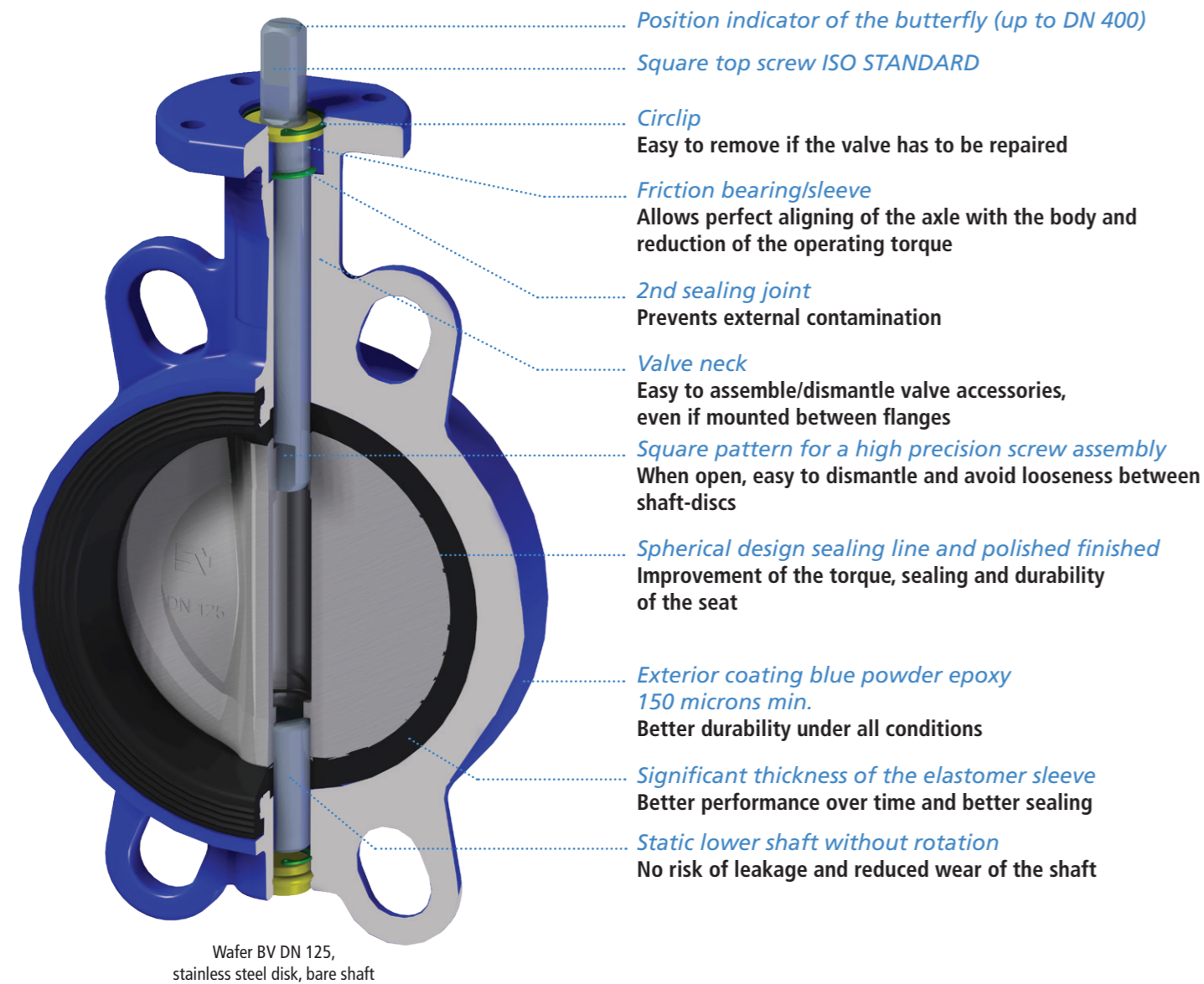

TABLE OF CONTENTS

	page
■ Performances and avantages	2
■ Quality assurance	4
■ Technical performance	6
■ Complete Wafer and Lug BV solutions	8
■ Wafer and Lug BV coding	8
■ Wafer BV drawings, materials and coatings	12
■ Lug BV drawings, materials and coatings	14
■ Other materials and coatings suitable for your needs	16
■ Wafer BV dimensions and references	18
■ Lug BV dimensions and references	24
■ Manual handlever actuators	30
■ Manual gearbox with handwheel	32
■ Electric motorised actuators	34
■ Pneumatic motorised actuators	36
■ Fastenings and associated products	38
■ Assembly and maintenance instructions	40

- Minimum operating torque and loss of load
- Fully leakproof (Ratio A) with unitary tests
- Flow of fluid in both directions

- Simple assembly and disassembly, all the components are interchangeable
- The butterfly, seat and shaft can be repaired
- No need of flat sealing joints for fixing to the network



- The design, manufacture and unitary tests are conducted in compliance with the quality assurance system EN ISO 9001:2008 certified by AENOR and by IQNet under no. ES-0780/1997.
- Compliant with EN 1074-2 standards, Directive for pressurised equipment 97/23/CE for industrial applications and the Atex Directive 94/4/CE for explosive atmospheres.
- The valves are certified for installation in naval construction, in explosive atmosphere and for transporting fluids in some countries,...

COMPLIANCE WITH THE STANDARDS AND DIRECTIVES

DIMENSIONS

- NF EN 593: metallic butterfly valves
- NF EN 558-1: face to face dimensions series 20
- EN ISO 5752: metal valves for use in flanged pipe systems (table 5 short series)
- API 609: Flange-Flange, Lug and Wafer Butterfly valves
- NF EN 1092-2: Cast iron flanges for connecting to pipes

MATERIALS: NNF EN 1503-3: valves.
Materials for body, lids, caps in cast iron

CONNECTION OF CONTROLS

- EN ISO 5210: multi-turn
- EN ISO 5211: fraction of a turn

ASSEMBLY BETWEEN FLANGES

- ISO PN10, DIN 2632 PN10, EN-1092 PN10, NFE 29222 PN10

IDENTIFICATION: EN ISO 5209: Marking

PERFORMANCE: EN 1074-2

TESTING

- EN ISO 5208: Test pressure (RatioA - No leak permitted)
- EN 12 266-1: Sealing - pressurised testing (RatioA - No leak permitted)

PRODUCTS FOR CONSTRUCTION

Directive for pressurised equipment 97/23/EC No. 056

EXPLOSIVE ATMOSPHERE

Directive 94/4/CEATEX type "II 2 GD c X" for valves and manual gear units No. SIRA 10XT267



SEALING AND UNITARY MECHANICAL RESISTANCE TESTS

A leakage test is made on each valve according to EN ISO 5208 and EN 12266-1: leakage - pressure tests (Ratio A – no leak permitted). For the butterfly, the test is made on each side with the butterfly closed, at a pressure equal to 1.1 x PFA (bar).

For the product assembly, the test is made with the butterfly semi-open, under a pressure equal to 1.5 x PFA (bar).

Upon customer's request, other certificates, tests or quality acceptances can be carried out.

If a 3.1 type unitary quality control is requested, each BV will be supplied with a document containing quality information of the assembly, hydraulic testing and inspection stages.



UNITARY IDENTIFICATION AND TRACEABILITY

Identification is compilation with the EN ISO 5209 standards "Marking". Marks on material of body and butterfly, as well as all the sticker labels, provides information about the type of material, the chemical composition and the mechanical performance until its end of life.

MARKINGS OF MATERIALS

- **Body:** diameter, pressure, manufacturer, casting no. and material
- **Butterfly:** diameter, manufacturer, material and casting no.

LABELS

Standard and traceability aspect: labels stuck on each valve.

- 1 Directive of CE pressure equipment: placed in front of the body
- 2 Rectangular label protected with actuator: placed on the flange of the body
- 3 Commercial aspect: label stuck on each valve. One single label to be selected placed in front of the body
- 4 Standard range PAM brand: EPDM elastomer with ACS
- 5 DVGW special range: EPDM elastomer W270 type certified by DVGW

Special scenario for explosive atmospheres

- 5 Only on the BV in compliance with the ATEX directive

UNITARY IDENTIFICATION

Upon the customer's request, a unit identification per product is possible. This identification must appear on the label of the square CE marking and in the rectangular placed on the mounting flange for the actuator. Contact us.

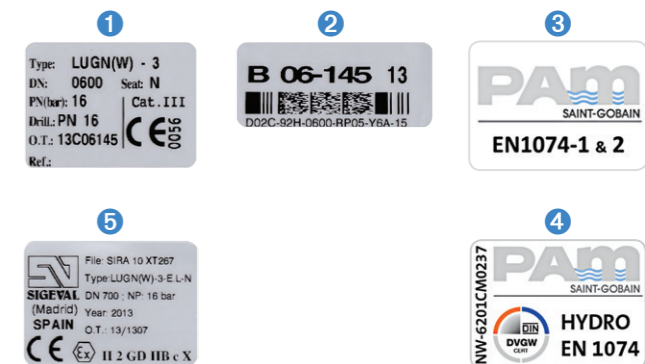
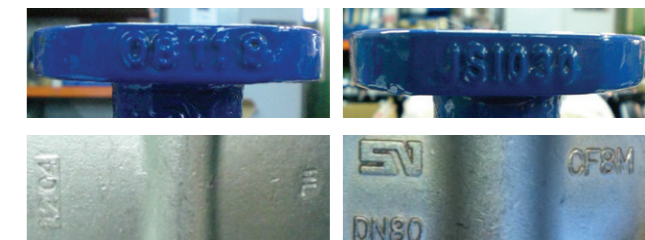

	ACS (and others except DVGW)	DVGW
Without ATEX	1 2 3	1 2 4
With ATEX	1 2 3 5	1 2 4 5

TESTING

The DN 40-1200 concentric Butterfly Valve range with elastomer in EPDM was tested in the CARSO laboratory - certified by the French Ministry of Health - and obtained the Sanitary Compliance Certificate in line with the order of 29 May 1997 under ACS no. 10ACC LY 19.

The range with elastomer of W270 quality was tested according to German regulation DVGW at the TZW laboratory and obtained approval no. NW-6201CM0237.

The same range is certified, in Russia by the accredited body GOST, for contact with drinking water (no. 78.01.01.515).



STANDARDISATION FOR OTHER FIELDS OF ACTIVITY

NAVAL CONSTRUCTION

This range is certified with regard to the three main certifying bodies of products for the naval construction market: DNV (Det Norske Veritas), Lloyd's Register and BureauVeritas.

GOST FOR THE GAS NETWORK IN RUSSIA



Technical performances

HYDRAULIC CHARACTERISTICS

- The Pressure drop the valve expressed through Kv, i.e. the flow, at a temperature of 20°C, passing the valve while resulting in a loss of load of 1 bar.
- In case of water, we have the following simplified relationship:

$$Kv = \frac{Q}{\sqrt{\Delta P}}$$

Where:

- Q = flow travelling in m³ /h,
- Kv = flowrate coefficient of the valve in m³/h,
- ΔP = Pressure loss in bar



Values of Kv in m³/h, depending on the diameter and the degree of opening of the valve

DN	Degree of opening of the butterfly (*)							
	25	30	40	50	60	70	80	90
40	2,5	4,3	9	15	22	38	60	68
50	5	7.7	14	23	45	60	90	112
60-65	8,6	12.9	22	36	70	90	138	172
80	13	19	33	54	110	138	207	258
100	24	36	63	103	200	260	410	474
125	52	76	133	215	420	540	860	970
150	146	125	215	353	690	890	1420	1680
200	146	215	360	603	1120	1510	2350	2800
250	224	336	580	990	1850	3190	3700	4310
300	327	475	860	1380	2670	3490	5215	6465
350	430	645	1120	1896	3535	4395	6980	8620
400	560	775	1465	2285	4395	5600	9310	10775
450	775	1077	1980	3190	6120	7930	12700	15086
500	970	1380	2415	3965	7500	9900	15085	18965
600	1293	1895	3275	5260	10130	14225	20700	24137
700	1350	1990	3860	5980	10600	17100	25300	36000
800	1600	2200	4500	8200	12500	20000	29000	44000
900	1800	2300	6100	10400	17500	29000	42000	58000
1000	2500	3800	8700	13500	23000	37500	59200	80500
1100	4450	6350	10560	18210	28650	54560	72540	97586
1200	5400	7800	12500	22600	35500	61500	82000	110500

Note : Values of the table are valid for the Wafer and Lug BV.

OPERATING TORQUES

- Torque in Nm required for seal closing (ratio A) based on the diameter and differential pressure. These torques were tested for the standard range with water at 20°C, optimal assembly and EPDM seat.

Pressure (Bar)	DN																			
	40	50	65	80	100	125	150	200	250	300	350	400	450	500	600	700	800	900	1000	1200
3	5	5	15	17	22	39	48	90	126	161	245	520	590	840	1000	1650	2300	4700	6500	8500
6	6	7	16	20	29	46	75	120	210	270	300	624	1120	1390	2200	3300	4600	6800	8500	12000
10	9	13	20	23	42	72	90	140	270	390	500	897	1450	1800	3450	5000	6500	8500	11500	15500
16	15	17	25	28	50	85	110	215	350	560	950	1400	1950	2500	3800	5860	9500	11500	15000	22000

Note : Values of the table are valid for the Wafer and Lug BV.



Lug BV DN 100 PN10/16 manual with handwheel gear unit and butterfly in CF8M stainless steel

Wafer BV DN 100 PN10/16 manual with handlever and butterfly in DI coated with min. 150 microns black epoxy



4 STEPS TO SELECT THE PRODUCT THAT MEETS YOUR REQUIREMENTS

- 1 TYPE OF BUTTERFLY VALVE
- 2 TYPE OF ACTUATOR
- 3 MATERIALS AND COATINGS
- 4 ACCESSORIES

Saint-Gobain PAM has a wide range of actuator and operating accessory solutions suited to your needs. Please contact our technical sales department.

For other fluids, Saint-Gobain PAM has a diverse range of materials, coatings and colours for the body, butterfly, seat and operating shaft.

1 TYPE OF BUTTERFLY VALVE

WAFER DN 40-1200

DN 40-150: PN10/16
DN 200-1200: PN10 and PN16
DN 40-300: PN25

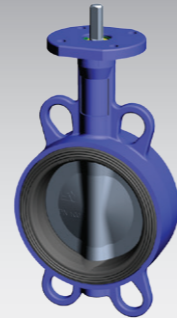

1 TYPE OF BUTTERFLY VALVE

LUG DN 40-1000

DN 40-150: PN10/16
DN 200-1000: PN10 and PN16
DN 40-300: PN25

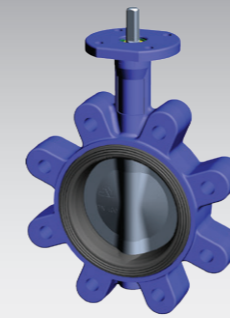

2 TYPE OF ACTUATOR

MANUAL

WITH HANDLEVER

MN Type
DN 40-200



MR Type
DN 40-350



GEARBOX WITH HANDWHEEL

MDV Type
PFA10/16 bar: DN 40-1200
PN25: DN 40-300



2 TYPE OF ACTUATOR

MOTORISED

ELECTRIC

AUMA
(single-phase or three-phase)



BERNARD
(single-phase or three-phase)



PNEUMATIC

Spring return



Double effect



3 MATERIALS AND COATINGS

BODY



- Ductile iron + 150 µm blue epoxy
- Ductile iron + epoxy in other colours (can be customised)
- Grey cast iron + 150 µm epoxy
- Aluminium
- Stainless steel
- Others, please contact us.

See page 16

BUTTERFLY



- Ductile iron + 150 µm black epoxy
- CF8M stainless steel
- Duplex and super Duplex
- Cupro-aluminium
- Ductile Iron 150 µm Rilsan®
- Others, please contact us.

See page 16

SEAT



- EPDM with ACS
- EPDM with DVGW
- NITRILE
- HYPALON®
- FLUCAST
- Others, please contact us.

See page 17

4 ACCESSORIES

POSITION INDICATOR (mechanical/electric)

Standard version
(mechanical switch)



ATEX version
(inductive switch)



DECLUTCHABLE GEARBOX

For actionneur
Pneumatic



REGULATION AND CONTROL



SOLENOID VALVE

For pneumatic actuator





Lug BV DN 700 PN16 bare shaft with DI butterfly coated with Rilsan® 180 microns min.

Wafer and Lug BV coding

References of the range of Wafer and Lug concentric Butterfly Valves has 10 characters.



DEFINITION OF THE REFERENCE

1+2	BV type concentric	Wafer				Lug			Flange		
		VW				VL			VB		
3 + 4 + 5	Diameter	DN40	DN50	DN60	DN65	DN80	DN100	DN125	DN150	DN200	DN250
		A40	A50	A60	A65	A80	B10	B12	B15	B20	B25
		DN300	DN350	DN400	DN450	DN500	DN600	DN700	DN800	DN900	
		B30	B35	B40	B45	B50	B60	B70	B80	B90	
		DN1000	DN1100	DN1200	DN1300	DN1400	DN1500	DN1600			
6	Disk/butterfly material	Ductile Iron + min. 150 µm epoxy					CF8M Stainless Steel				
		F					A				
7	Actuator	Bare shaft without mechanism									
		A									
		Manual	With handlever				gearbox with handwheel				
			L				B				
		Electrical-motorised	Auma Three-phase			Auma Single-phase		Bernard Three-phase		Bernard Single-phase	
E			M		Y		Z				
Electrical-motorised	Spring return				Double effect						
	X				P						
8	Rated pressure	PFA10/16 bar	PFA10 bar			PFA16 bar		PN20	PN25		
		C	B			A		F	D		
9	Coatings	150 µm blue powdered epoxy					150 µm red powdered epoxy				
		W					F				
10	Type of joint/sleeve	EPDM with ACS			EPDM with DVGW		Nitrile		Viton		
		E			W		N		V		

Example:

VWB10AMCWN = Wafer BV DN 100 motorised electric single-phase Auma PFA10/16 with disk in CF8M stainless steel and blue epoxy 150 microns and seat in nitrile.

For other types of materials, coatings, pressures or actuators, contact us.



The Wafer Butterfly Valve is manufactured for a range of diameters from DN 40 to DN 1200 PFA 16 bar and DN 40-300 PFA 25 bar.

COMMON COMPONENTS TO WAFER BV

Ref.	Description	Material	Coating
1	Valve body	Ductile iron EN GJS-400-15	Min. 150 µ RAL 5005 blue powder epoxy
2	Friction bearing	Acetal "DELTRIN" (POM)	-
3	O-ring	Nitrile	-
4	Upper axle	X20Cr13 Stainless steel as per EN10088-3	-
5	Seat	EPDM elastomer with ACS	-
6	Disk	Ductile iron EN GJS-400-15 (*) CF8M stainless steel (contact us) (**)	Min. 150 µ black powder epoxy with ACS
7	Lower axle	Stainless steel AISI 420	-

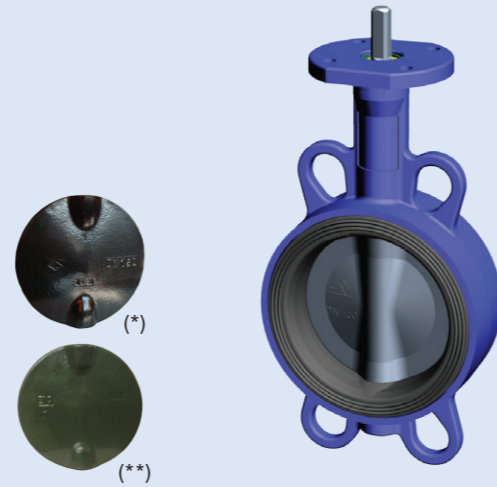

COMPONENTS RANGE DN 40-200

Ref.	Description	Material	Coating
8	Lock washer	Galvanised steel	-
9	Circlip	Galvanised steel	DIN 472
10	Lower plug	EPDM	-
11	Friction bearing	Acetal "DELTRIN" (POM)	-
12	Marking	Polyester	-

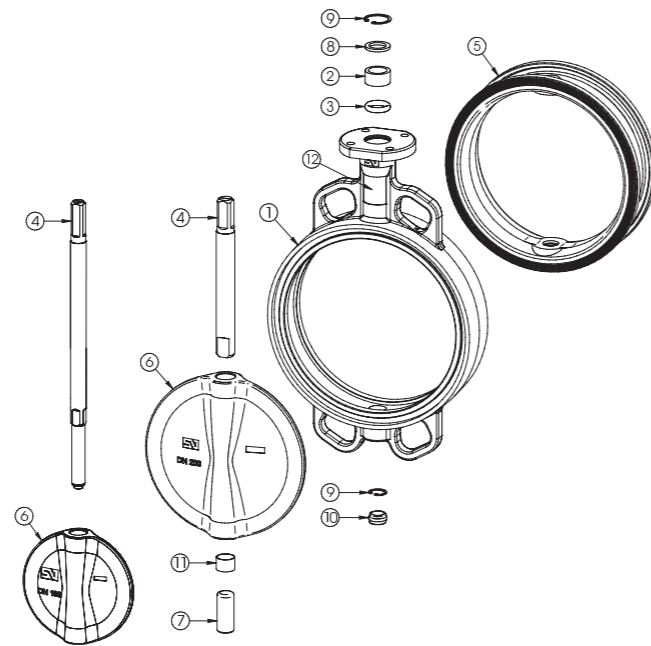
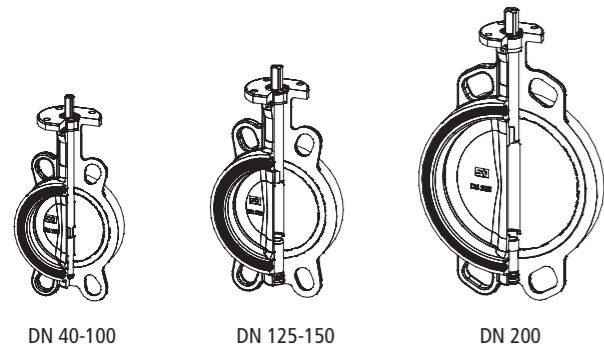

COMPONENTS RANGE DN 250-500

Ref.	Description	Material	Coating
8	Lock washer	Galvanised steel	-
9	Circlip	Galvanised steel	DIN 472
10	Lower plug	EPDM elastomer	-
11	Cylindrical pin (2 DN250-300) (4 DN350-400)	Carbon steel	100Cr6
12	Friction bearing	BZ steel	PTFE
13	Marking	Polyester	-

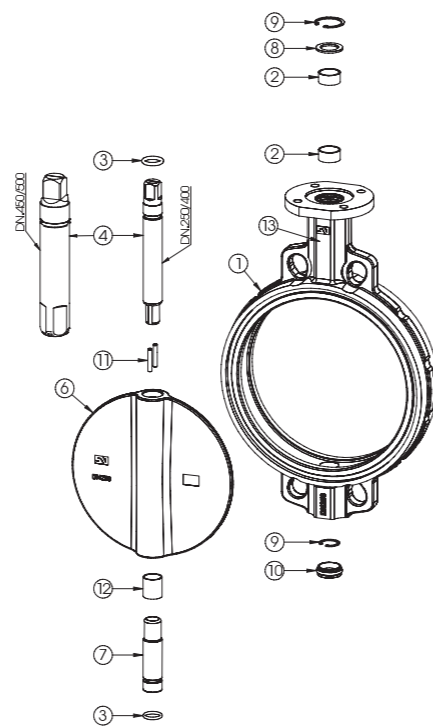
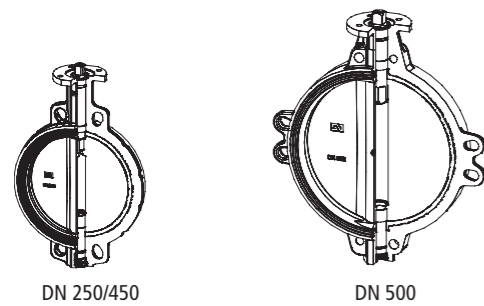

COMPONENTS RANGE DN 600-1100

Ref.	Description	Material	Coating
8	Upper lid	Carbon steel	Black powder epoxy
9	Lock washer	Galvanised steel	-
10	Circlip	Galvanised steel	DIN 472
11	Lower plug	EPDM elastomer	-
12	Elastic washer	Galvanised steel	DIN 913
13	Axle elastic washer (DN 600/800 seul)	Galvanised steel	DIN 471
14	Marking	Polyester	-

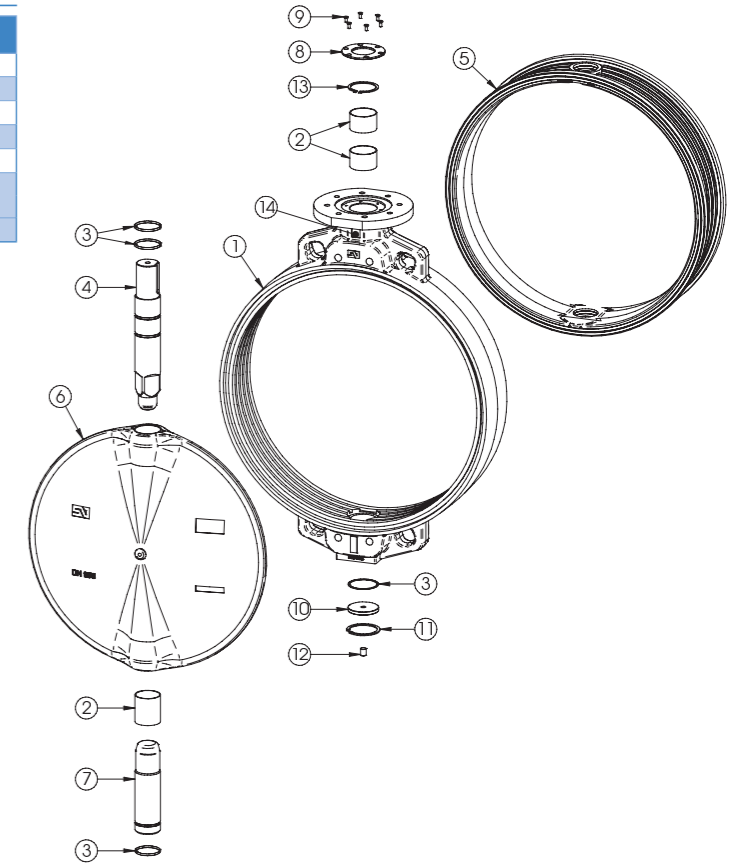
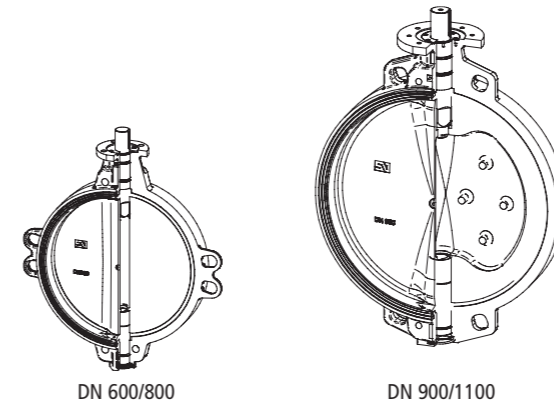

COMPONENTS RANGE DN 1200

Ref.	Description	Material	Coating
8	Upper lid	Carbon steel	Black powder epoxy
9	Upper lid screw	Galvanised steel	DIN 7991
10	Lower over	Galvanised steel	-
11	Lower screw	Galvanised steel	DIN 931
12	Lower elastic washer	Bronze	-
13	Disk	Galvanised steel	-
14	Screw	Galvanised steel	DIN 913
15	Pin	Galvanised steel	DIN 934
16	Guides	X20Cr13 Stainless steel as per EN10088-3	-
17	Bearing	Steel-Bz	PTFE

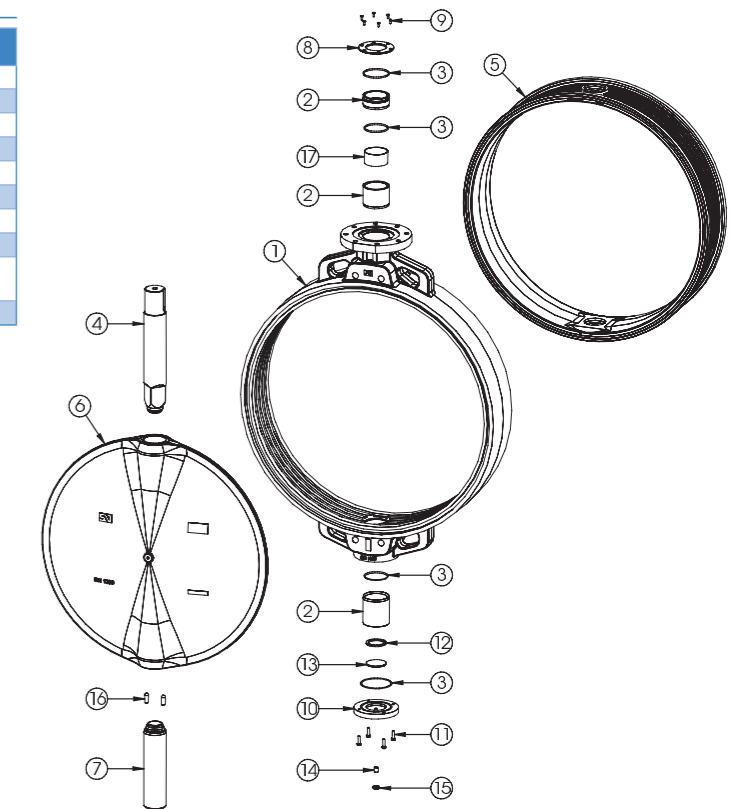
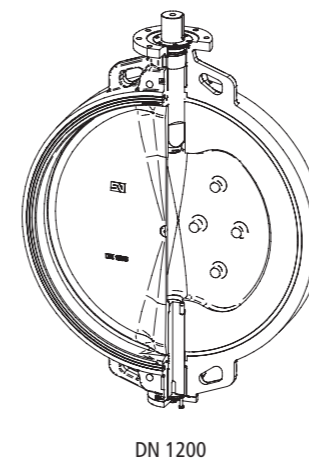

Lug BV drawings, materials and coatings

The Lug Butterfly Valve is manufactured for a range of diameters from **DN 40 to DN 1000mm PFA 16 bar and DN 40-300 PFA 25 bar.**

COMPONENTS COMMON TO LUG BV

Ref.	Description	Material	Coating
1	Valve body	Ductile iron EN GJS-400-15	Min. 150 µ RAL 5005 blue powder epoxy
2	Friction bearing	Acetal "DELTRIN" (POM)	-
3	O-ring	Nitrile	-
4	Upper axle	X20Cr13 Stainless steel as per EN 10088-3	-
5	Seat	EPDM elastomer with ACS (nitrile in sanitation)	-
6	Butterfly	Ductile iron EN GJS-400-15 (*) CF8M stainless steel (**)	Min. 150 microns black powder epoxy with ACS
7	Lower axle	X20Cr13 Stainless steel as per EN 10088-3	-

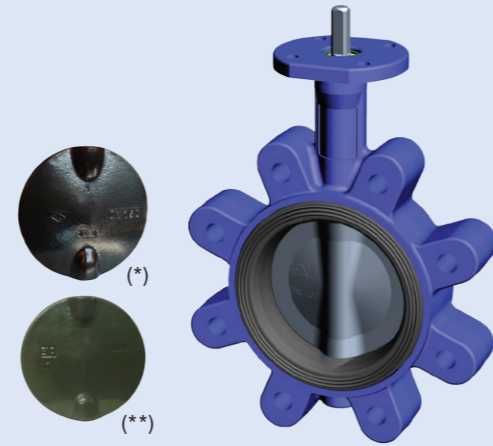

COMPONENTS RANGE DN 250-500

Ref.	Description	Material	Coating
8	Lock washer	Galvanised steel	-
9	Circlip	Galvanised steel	DIN 472
10	Lower plug	EPDM elastomer	-
11	Cylindrical pin (2 DN250-300) (4 DN350-400)	Carbon steel	100Cr6
12	Friction bearing	BZ steel	PTFE
13	Marking	Polyester	-

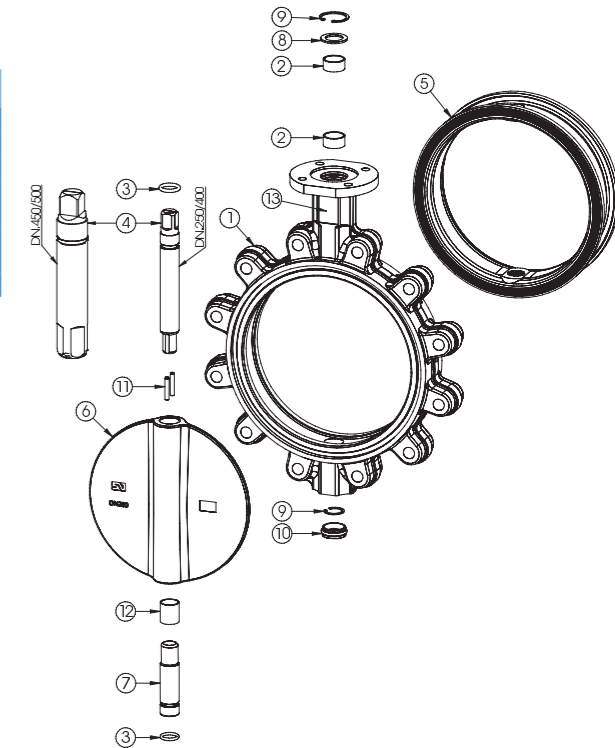
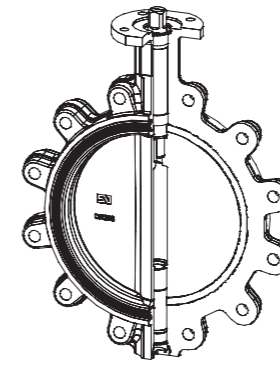

COMPONENTS RANGE DN 40-200

Ref.	Description	Material	Coating
8	Lock washer	Galvanised steel	-
9	Circlip	Galvanised steel	DIN 472
10	Lower plug	EPDM	-
11	Friction bearing	Acetal "DELTRIN" (POM)	-
12	Marking	Polyester	-

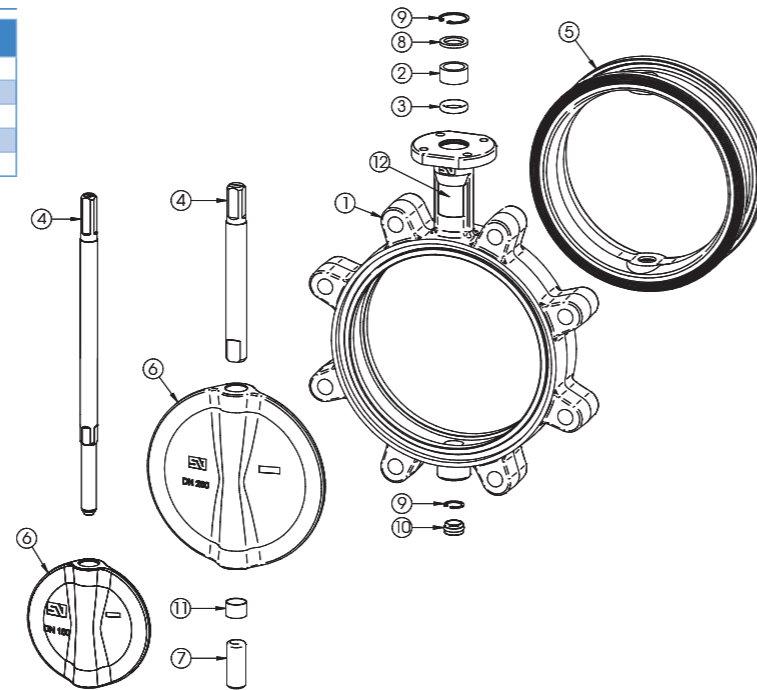
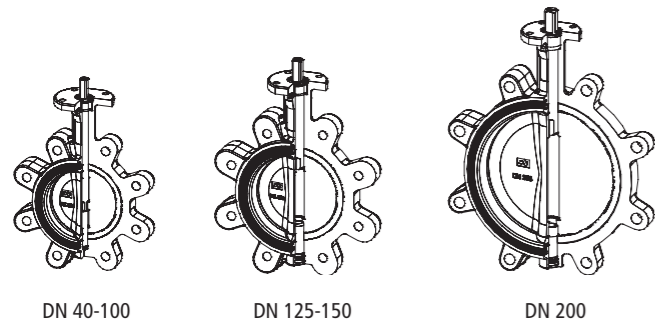

COMPONENTS RANGE DN 600-1000

Ref.	Description	Material	Coating
8	Upper lid	Carbon steel	Black powder epoxy
9	Circlip	Galvanised steel	DIN 472
10	Lower plug	EPDM elastomer	-
11	Elastic washer	Galvanised steel	-
12	Lock washer	Nickel steel	DIN 471
14	Marking	Polyester	-

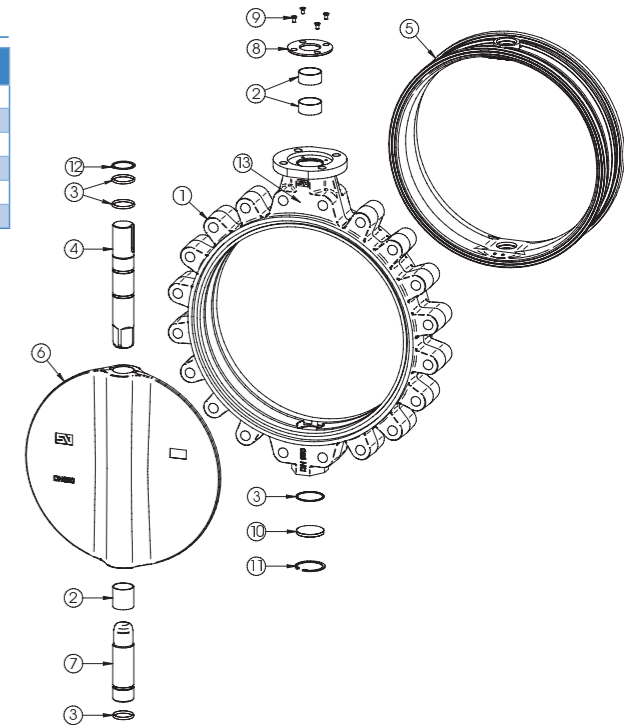
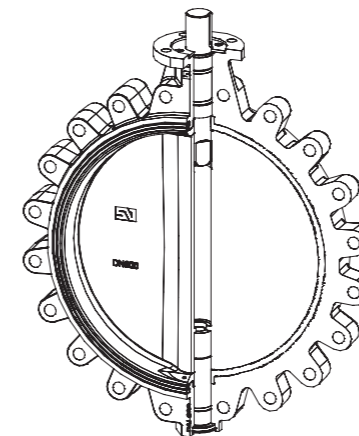

- The Wafer and Lug type short pattern BV from Saint-Gobain PAM are suitable for all types of fluids and situations.
- The diversity of materials and coatings meet the market requirements of water, sanitation, industry and other applications.
- One solution for each fluid to be conveyed: drinking water, raw water, waste water, sea water, water with suspended solids, transporting steam viscous fluids, etc.

BODY

Standard solution

Material + coating	Standards conformity	Applications
Ductile iron + 150 µm RAL 5005 blue powder epoxy	EN GJS 400-15 (DIN 1693 GGG 40)	Prescriptive market

Other solutions

Material + coating	Standards conformity	Applications
Grey cast iron + 150 µm powder epoxy	EN GJL-250 (DIN 1691 GG 25)	Irrigation
Carbon steel + 150 µm powder epoxy	ASTM A 216 / A216M WCB	
Carbon steel + 150 µm powder epoxy	EN 10025 S 275 JR	
Stainless steel	ASTM A 351 / 351M CF8 / CF8M	Corrosive environment
Stainless steel	AISI 304 / 316	Corrosive environment
Aluminium	EN AC 47100 / EN AC 46100	Optimised weight
Bronze	DIN 1705 Rg 10	Corrosive environment

For other types of coatings, thicknesses or colours, see next page or contact our technical sales department.



BUTTERFLY/DISK

Standard solution

Material + coating	Standards conformity	Characteristics	Applications
Black ductile iron + 150 µm black powder epoxy (1)	EN GJS 400-15 (DIN 1693 GGG 40)	Good mechanical resistance similar to carbon steel	Hot water (max. 90°C) air and gas
Stainless steel CF8M (2)	ASTM A 351 / 351M CF8 / CF8M	Very good chemical resistance and resistance to corrosion	Demineralised water, chemical and food products

Other solutions

Material + coating	Standards conformity	Characteristics	Applications
Vulcanised ductile iron (3)	EN GJS 400-15 (DIN 1693 GGG 40) + EPDM	Very good chemical resistance and resistance to corrosion	Fluids with suspended solids and sea water
Ductile Iron coated Rilsan®	EN GJS 400-15 (DIN 1693 GGG 40) + Rilsan®	Good mechanical resistance similar to carbon steel	Hot water (max. 90°), industrial oils, air, etc.
Stainless steel CF3M	A 351 Gr. CF3M	Very good chemical resistance and resistance to corrosion	Demineralised water, chemical and food products
Stainless steel CF8 (4)	ASTM A 351 / 351M CF8	Very good chemical resistance and resistance to corrosion	Chemical and food products
Stainless steel CF8M + polishing treatment (5)	ASTM A 351 / 351M CF8 / CF8M	Very good chemical resistance and resistance to corrosion	Chemical and food products
Stainless steel CF8M coated with HALAR (6)	ASTM A 351 / 351M CF8 / CF8M	Very good chemical resistance and resistance to corrosion	Chemical products and sea water
Duplex	ASTM A 351 / 351M CD4MCu (NORIDUR)	Very good chemical resistance and resistance to corrosion	Chemical products
Super duplex	14469	Very good chemical resistance and resistance to corrosion	Sea water and gas corrosives
Super austenitic	14539 B6 904L (Uranus)	Very good chemical resistance and resistance to corrosion	Chemical products
Bronze-Tin	DIN 1705 Rg 10 (DN<300)	Good mechanical resistance similar to carbon steel	Sea water
Bronze-Aluminium (7)	UNE EN 1982 (cuAl10fesni5c) (DN>350)	Good mechanical resistance similar to carbon steel	Sea water
Aluminium	En AC 44100	Very good chemical resistance and resistance to corrosion	Cold water and air
Carbon steel	ASTM A 216 / A216M WCB	Good mechanical resistance similar to carbon steel	Water and gas

All technical information about resistances, temperatures and applications is for information only. Saint-Gobain PAM reserves the right to change it without prior notice. Saint-Gobain PAM shall not be liable for possible consequences of wrong use of information included in these tables.



SEAT

Standard solution

Material	Name	SGPAM	Colour code	Permissible temperatures	Applications
	ISO 1629				
Ethylene Propylene (1)	EPDM	E ACS	-	-20°C +110°C	Water, sea water, weak acids and bases

Other solutions

Material	Name	SGPAM	Colour code	Permissible temperatures	Applications
	ISO 1629				
Ethylene Propylene	EPDM	E	-	-20°C +110°C	Water, sea water, weak acids and bases
Ethylene Propylene with DVGW	EPDM	E DVGW	-	-20°C +95°C	Water, sea water, weak acids and bases
High temperature Ethylene Propylene	EPDM	HT	Grey	+80°C +130°C	Heating without presence of steam
Nitrile (2)	NBR	NC	Blue Yellow	-10°C +90°C	Oils and grease mineral and vegetal
Flucast AB/P	-	AP	Red	-10°C + 70°C	Powder abrasive products
Flucast AB/E	-	AE	Red Yellow	-20°C + 95°C	Oxygenated solvents, ketone, esters abrasive
Flucast AB/N	-	AN	Brown	-10°C + 100°C	Oils and grease mineral and vegetal abrasifs
Silicon (3)	MVQ	S	-	-60°C +200°C	Extreme temperature without presence of steam
Food Silicon (4)	MVQ	SA	-	- 60°C +200°C	Milk and food products
Steam Silicon (5)	MVQ	SV	Red White	-60°C +140°C	Steam at low pressure
Viton	FPM	V	Yellow	-15°C +210°C	Acids and fluids at high temperature
Hypalon®	CSM	H	Green	-25°C +125°C	Water, bases and acids non oxidative dissolved
Epichlorhydrine	ECO	EP	-	-40°C +125°C	Brine, low temperatures and hydrocarbons
Neoprene	CR	NP	White	-25°C + 80°C	Sea water, average resistance to oils and greases



OTHER COATINGS AND SURFACE TREATMENTS

Coating	Thickness	Applications
Power epoxy different colours (RAL)	150-300 µm	Protection for highly corrosive atmospheres
Resi-coat RT 9000 R4	150-300 µm	Good resistance at high T° food (KTW, WRC, KIWA)
Halar (Fluorescent)	500-800 µm	Good resistance to environments and high T° (150°)
Rilsan®	150-300 µm	High resistance to organic acids, salts, bases, solvents and hydrocarbons High resistance to abrasion and impacts.
Ebonite	-	Protection against water and sea

Surface treatment	Applications
Stainless steel shiny polishing	Pharmaceutical and food industry
Chromium	Highly aggressive environment



SHAFT

Basic solution is stainless steel AISI 420. For other requirements, here are other types of materials.

Material	Stainless steel	Duplex	Super Duplex	Alloy Ni-Cu	Alloy Al-Bronze	Alloy Ni-Cr-Mb
Description	AISI 316 and AISI 316 L	1.4462	1.4541	MONEL K 500	QAL-10 Cu Al10 Fe Ni S-C	INCONEL 625



In case of other very specific requests, please contact us.

All technical information about resistances, temperatures and applications is for information only. Saint-Gobain PAM reserves the right to change it without prior notice.

Wafer BV dimensions and references

- The Wafer Butterfly Valve is manufactured for a range of diameters from DN 40 to DN 1200mm.
- Specially designed for conveyance of drinking water, pumping stations, waste water treatment, desalinisation, fire-fighting networks, naval construction, air-conditioning, etc. This BV is installed between two flanges using ties that do not allow isolating the two sides for network maintenance.



DN	Manual				Motorised						
	Lever based		Gear unit based		Electric				Pneumatic		
	DI Disk	Stainless Steel disk	DI Disk	Stainless Steel disk	Auma		Bernard		Double effect	Spring return	
40											
50											
60-65	PN 10/16	PN25	PN 10/16	PN25	PN 10/16	PN25	PN 10/16	PN25	PN 10/16	PN 10/16	PN 10/16
80											
100											
125											
150											
200	PN10	PN10	PN10 and PN16	PN10 and PN16	PN10 and PN16	PN10 and PN16	PN10 and PN16	PN10 and PN16	PN10	PN10	PN10
250											
300											
350											
400											
450											
500											
600											
700											
800											
900											
1000											
1100											
1200											

SIZE WAFER BV WITH HANDLEVER

"MN" TYPE

DN		Handlever								
mm	Inches	C	X	E2	H2	Y2	L2	M2	Weight	
40	1 1/2"	33	76	49	159	215	220	90	2.1	
50	2"	43	100	49	169	230	220	90	2.9	
65	2 1/2"	46	108	49	184	253	220	90	3	
80	3"	46	124	60	201	295	260	90	3.6	
100	4"	52	147	60	225	331	260	90	4.4	
125	5"	56	180	75	255	381	315	90	6.6	
150	6"	56	206	75	268	401	315	90	7.6	
200	8"	60	257	75	300	470	315	90	11.6	

Dimensions in mm, weight in kg.

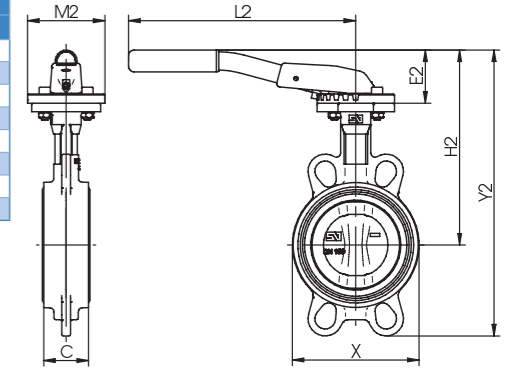

"MR" TYPE

DN		Handlever								
mm	Inches	C	X	E3	H3	Y3	L3	M3	Weight	
40	1 1/2"	33	76	115	225	281	260	90	2.3	
50	2"	43	100	115	235	296	260	90	3.1	
65	2 1/2"	46	108	115	250	319	260	90	3.2	
80	3"	46	124	115	256	350	260	90	3.7	
100	4"	52	147	115	280	386	260	90	4.5	
125	5"	56	180	115	295	421	310	90	6.8	
150	6"	56	206	115	308	441	310	90	7.9	
200	8"	60	257	115	340	510	310	90	11.7	
250	10"	68	324	120	402	612	500	130	22.2	
300	12"	78	376	120	428	668	500	130	31.2	
350	14"	78	430	120	458	722	500	130	37.1	

Dimensions in mm, weight in kg.

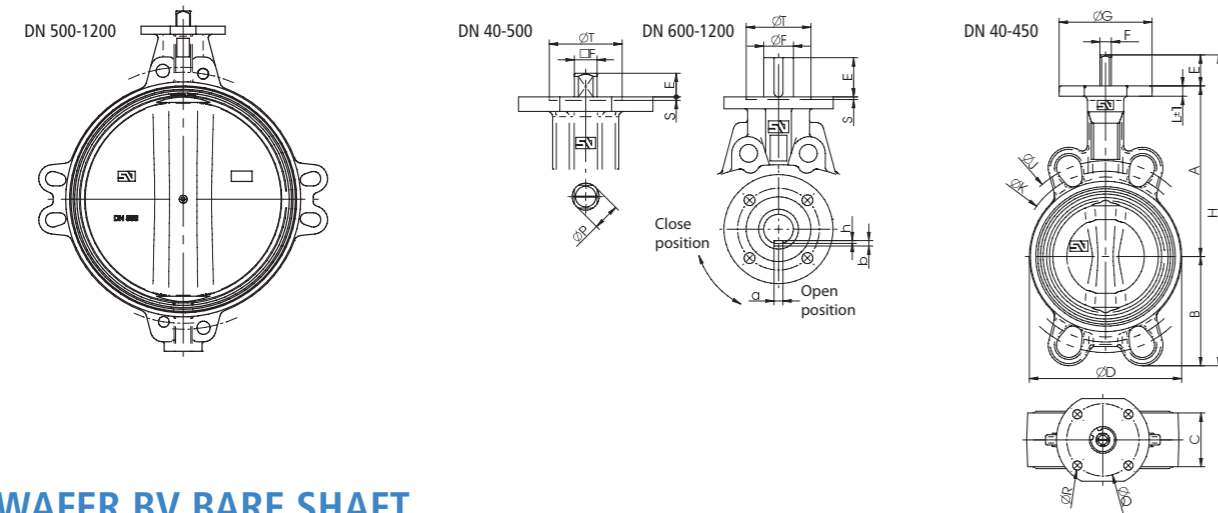
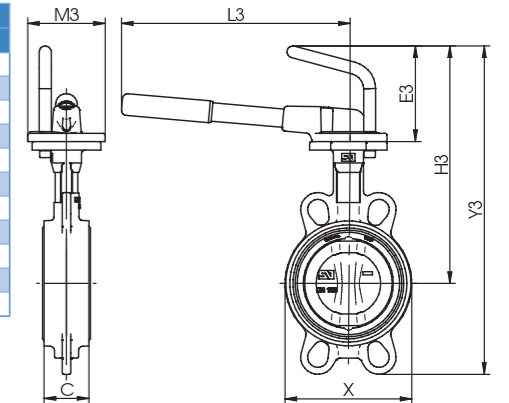

SIZE WAFER BV BARE SHAFT

DN		ISO	General dimensions											Weight
mm	Inches		A	B	C	D	E	F	G	H	J	L	K	
40	1 1/2"	F-07	110	56	33	76	30	11	90	196	110	95	10	1.7
50	2"	F-07	120	61.5	43	100	30	11	90	211.5	123	120.6	10	2.4
65	2 1/2"	F-07	135	69	46	108	30	11	90	234	145	127	10	2.6
80	3"	F-07	141	94	46	124	30	11	90	265	160	145	10	3.1
100	4"	F-07	165	106	52	147	30	11	90	301	185.5	165	10	4.0
125	5"	F-07	180	126.5	56	180	33	14	90	339.5	225	206	12	6.1
150	6"	F-07	193	133	56	206	33	14	90	359	241.3	229	12	7.3
200	8"	F-07	225	170	60	257	33	17	90	428	305	280	12	11
250	10"	F-10	282.5	210	68	324	23	22	130	515.5	362	335	14	20.5
300	12"	F-10	308	240	78	376	23	22	130	571	431.8	394	14	29.5
350	14"	F-10	338.5	263	78	430	31	22	160	632.5	476.3	445	15	35.4
400	16"	F-12	380	308	102	485	31	27	160	719	540	510	18	55.7
450	18"	F-14	380.5	340	114	536	38	36	190	758.5			20	80.8
500	20"	F-14	432.5	380	127	593	38	36	210	850.5			20	114
600	24"	F-16	494	440	154	690	80	60	210	1014			24	170.6
700	28"	F-25	590	490	165	830	106	65	300	1186			30	252
800	32"	F-25	630	565	190	902	106	80	300	1301			28	347
900	36"	F-25	695	610	203	1010	110	80	350	1415			32	457
1000	40"	F-25	770	675	216	1116	110	80	350	1555			32	580
1100	44"	F-25	815	733	216	1215	110	80	350	1658			32	701
1200	48"	F-30	875	818	254	1334	110	100	350	1803			40	959

Dimensions in mm, weight in kg.

SIZE WAFER BV WITH MANUAL HANDWHEEL GEAR UNIT

DN		MDV type gear unit with handwheel										Weight
mm	Inches	C	X	Model	E4	H4	Y4	L4	M4	N		
40	1 1/2"	33	76	MDV - 0	125	198	254	128	43,5	50	2.9	
50	2"	43	100	MDV - 0	125	208	269	128	43,5	50	3.7	
65	2 1/2"	46	108	MDV - 0	125	223	292	128	43,5	50	3.8	
80	3"	46	124	MDV - 0	125	229	323	128	43,5	50	4.3	
100	4"	52	147	MDV - 0	125	253	359	128	43,5	50	5.2	
125	5"	56	180	MDV - 1	160	286	412	135	43,5	50	7.5	
150	6"	56	206	MDV - 1	160	298	431	135	43,5	50	8.7	
200	8"	60	257	MDV - 1A	200	355	525	152	52,5	57	13.6	
250	10"	68	324	MDV - 2	250	442	652	222	61	70	24	
300	12"	78	376	MDV - 2	250	468	708	222	61	70	33	
350	14"	78	430	MDV - 2	250	498	761	222	61	70	39	
400	16"	102	485	MDV - 2A	300	572	880	278	69	73	64.6	
450	18"	114	536	MDV - 3	400	630	970	321	96,5	92	99.2	
500	20"	127	593	MDV - 3	400	682	1062	321	96,5	92	132	
600	24"	154	690	MDV - 4	500	799	1239	408	138	140	205	
700	28"	165	830	MDV - 4	600	945	1435	424	138	140	331.8	
800	32"	190	902	MDV - 5	600	985	1550	456	138	156	423.6	
900	36"	203	1010	MDV - 6	700	1108	1718	510	180	156	557.0	
1000	40"	216	1116	MDV - 7	700	1183	1858	579	180	156	659.0	
1100	44"	216	1215	MDV - 7	700	1229	1962	579	180	156	786.0	
1200	48"	254	1134	MDV - 8	700	1310	2128	593	252	201	1256.6	

Dimensions in mm, weight in kg.

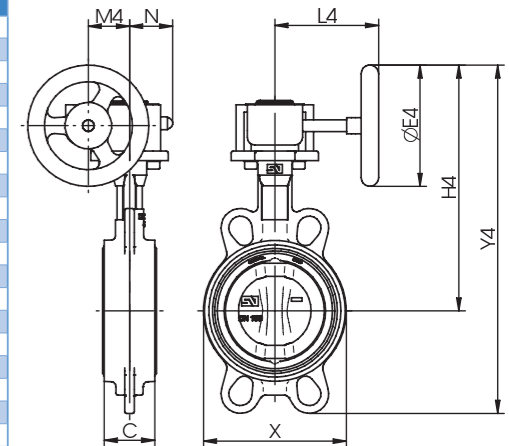

SIZE AUMA ELECTRIC MOTORISED WAFER BV PFA10 bar

DN		Gear unit and servomotor mechanism	Dimensions						Weight (kg)
mm	Inches		A3	B3	C3	D3	E3	H3	
40	1 1/2"	SG 03.3	92	210	207	215	119	320	10.0
50	2"	SG 03.3	92	210	207	215	119	327	10.7
65	2 1/2"	SG 03.3	92	210	207	215	119	342	10.9
80	3"	SG 04.3	92	210	207	215	119	348	11.4
100	4"	SG 04.3	92	210	207	215	119	372	12.3
125	5"	SG05.1	63	238	344	265	186	524	29.1
150	6"	SG05.1	63	238	344	265	186	537	30.3
200	8"	SG07.1	63	238	344	265	186	569	34
250	10"	SG10.1	80	248	361	265	191	643.5	47.5
300	12"	SG10.1	80	248	361	265	191	669	56.5
350	14"	SG10.1	80	248	361	265	191	699.5	62.4
400	16"	SG12.1	105	248	385	265	191	765	87.7
450	18"	GS100.3/VZ4.3/SA07.2	112.5	255	447	265	216	827.5	124
500	20"	GS100.3/VZ4.3/SA07.2	112.5	255	447	265	216	879.5	157
600	24"	GS100.3/VZ4.3 + SA07.6	547	189	313	164	287	807	231
700	28"	GS125.3/VZ4.3 + SA10.2	554	194	323	158	316	913	324
750	30"	GS125.3/VZ4.3 + SA10.2	554	194	323	158	316	913	366
800	32"	GS125.3/VZ4.3 + SA10.2	554	194	323	158	316	953	419
900	36"	GS160.3/GZ160.3(8:1) + SA07.6	628	290	313	165	346	1008	575
1000	40"	GS160.3/GZ160.3(8:1) + SA10.2	630	290	323	165	351	1093	698
1100	44"	GS160.3/GZ160.3(8:1) + SA10.2	630	290	323	165	351	1138	819
1200	48"	GS200.3/GZ200.3(8:1) + SA10.2	760	366	338	208	391	1213	1156

Dimensions in mm, weight in kg.

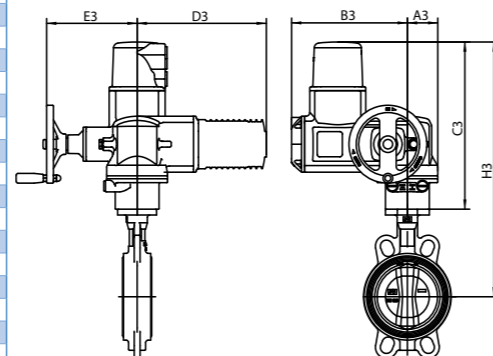

References correspond to the Wafer BV with ductile iron body EN GJS-400-15 + RAL 5005 min. 150 microns powder coated epoxy and seat/joint in EPDM elastomer with ACS. Contact us for other materials.

For other types of seats, change the letter in position 10 of the reference: N=Nitrile, W=EPDM DVGW, V=Viton.

REFERENCES WAFER BV PFA16 bar BARE SHAFT

DN mm	Weight (kg) PN10/16	DI butterfly + black 150 µm powder epoxy		CF8M stainless steel disk	
		PN10	PN16	PN10-	PN16
40	1.70	VWA40FACWE		VWA40AACWE	
50	2.40	VWA50FACWE		VWA50AACWE	
65	2.60	VWA65FACWE		VWA65AACWE	
80	3.10	VWA80FACWE		VWA80AACWE	
100	4.00	VWB10FACWE		VWB10AACWE	
125	6.10	VWB12FACWE		VWB12AACWE	
150	7.30	VWB15FACWE		VWB15AACWE	
200	11.00	VWB20FABWE	VWB20FAAWE	VWB20AABWE	VWB20AAAWE
250	20.50	VWB25FABWE	VWB25FAAWE	VWB25AABWE	VWB25AAAWE
300	29.50	VWB30FABWE	VWB30FAAWE	VWB30AABWE	VWB30AAAWE
350	35.40	VWB35FABWE	VWB35FAAWE	VWB35AABWE	VWB35AAAWE
400	55.70	VWB40FABWE	VWB40FAAWE	VWB40AABWE	VWB40AAAWE
450	80.80	VWB45FABWE	VWB45FAAWE	VWB45AABWE	VWB45AAAWE
500	114.00	VWB50FABWE	VWB50FAAWE	VWB50AABWE	VWB50AAAWE
600	170.60	VWB60FABWE	VWB60FAAWE	VWB60AABWE	VWB60AAAWE
700	252.00	VWB70FABWE	VWB70FAAWE	VWB70AABWE	VWB70AAAWE
800	347.00	VWB80FABWE	VWB80FAAWE	VWB80AABWE	VWB80AAAWE
900	457.00	VWB90FABWE	VWB90FAAWE	VWB90AABWE	VWB90AAAWE
1000	580.00	VWC10FABWE	VWC10FAAWE	VWC10AABWE	VWC10AAAWE
1100	701.00	VWC11FABWE	VWC11FAAWE	VWC11AABWE	VWC11AAAWE
1200	959.00	VWC12FABWE	VWC12FAAWE	VWC12AABWE	VWC12AAAWE

Wafer BV PFA25 bar DN 40-300 bare shaft (CF8M stainless steel butterfly), change position 8 letter with "D".



SIZE AUMA ELECTRIC MOTORISED WAFER BV PFA16 bar

DN		Gear unit and servomotor mechanism	Dimensions						Weight (kg)
mm	Inches		A3	B3	C3	D3	E3	H3	
200	8"	SG07.1	63	238	344	265	186	569	30
250	10"	SG10.1	80	248	361	265	191	643.5	46
300	12"	SG10.1	80	248	361	265	191	669	55
350	14"	SG12.1	105	248	385	265	191	723.5	65
400	16"	SG12.1	105	248	385	265	191	765	85
450	18"	GS100.3/VZ4.3/SA07.6	112.5	255	447	265	216	827.5	157
500	20"	GS100.3/VZ4.3/SA07.6	112.5	255	447	265	216	879.5	190
600	24"	GS100.3/VZ4.3 SA07.6	547	189	313	164	287	807	246.6
700	28"	GS125.3/VZ4.3 SA10.2	554	194	323	158	316	913	341
750	30"	GS125.3/VZ4.3 SA10.2	554	194	323	158	316	913	383
800	32"	GS160.3/GZ160.3(8:1) SA10.2	630	290	323	165	351	953	481
900	36"	GS160.3/GZ160.3(8:1) SA10.2	630	290	323	165	351	1018	591
1000	40"	GS200.3/GZ200.3(8:1) SA10.2	760	366	338	208	391	1108	793
1100	44"	GS200.3/GZ200.3(16:1) SA10.2	760	366	338	208	391	1153	914
1200	48"	GS200.3/GZ200.3(16:1) SA10.2	760	366	338	208	391	1213	1169

Dimensions in mm, weight in kg.

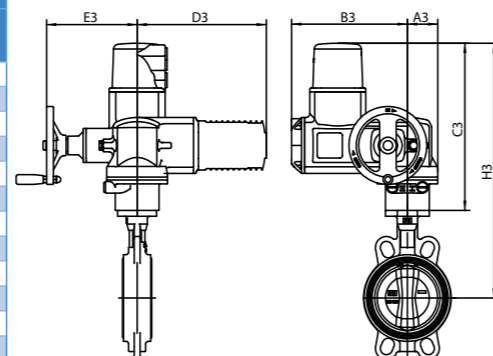

REFERENCES RAP WAFER PFA16 bar MANUAL WITH HANDLEVER

DN mm	Type Lever	Weight (kg)	Butterfly FD + epoxy poudre 150 µm noir		CF8M stainless steel disk	
			PN10/16	PN10	PN16	PN10-
40	MN	2.1		VWA40FLCWE		VWA40ALCWE
50	MN	2.9		VWA50FLCWE		VWA50ALCWE
65	MN	3.0		VWA65FLCWE		VWA65ALCWE
80	MN	3.6		VWA80FLCWE		VWA80ALCWE
100	MN	4.4		VWB10FLCWE		VWB10ALCWE
125	MN	6.6		VWB12FLCWE		VWB12ALCWE
150	MN	7.9		VWB15FLCWE		VWB15ALCWE
200	MR	11.7	VWB20FLBWE	VWB20FLAWE	VWB20ALBWE	VWB20ALAWWE
250	MR	22.2	VWB25FLBWE	VWB25FLAWE	VWB25ALBWE	VWB25ALAWWE
300	MR	31.2	VWB30FLBWE	VWB30FLAWE	VWB30ALBWE	VWB30ALAWWE

Wafer BV PFA25 bar DN 40-100 (CF8M stainless steel butterfly), change position 8 letter with "D".

Contact us for MR lever DN 40-150.



Contact us for the dimensions of Wafer BV with Bernard motorisation



REFERENCES WAFER BV PFA16 bar MANUAL HANDWHEEL WITH MDV GEAR UNIT

DN mm	Weight (kg) PN10/16	Gear unit	DI butterfly + black 150 µm powder		CF8M stainless steel disk	
			PN10	PN16	PN10-	PN16
40	2.9	MDV - 0	VWA40FBCWE		VWA40ABCWE	
50	3.7	MDV - 0	VWA50FBCWE		VWA50ABCWE	
65	3.8	MDV - 0	VWA65FBCWE		VWA65ABCWE	
80	4.3	MDV - 0	VWA80FBCWE		VWA80ABCWE	
100	5.2	MDV - 0	VWB10FBCWE		VWB10ABCWE	
125	7.5	MDV - 1	VWB12FBCWE		VWB12ABCWE	
150	8.7	MDV - 1	VWB15FBCWE		VWB15ABCWE	
200	13.6	MDV - 1A	VWB20FBBWE	VWB20FBAWE	VWB20ABBWE	VWB20ABAWWE
250	24.0	MDV - 2	VWB25FBBWE	VWB25FBAWE	VWB25ABBWE	VWB25ABAWWE
300	33.0	MDV - 2	VWB30FBBWE	VWB30FBAWE	VWB30ABBWE	VWB30ABAWWE
350	39.0	MDV - 2	VWB35FBBWE	VWB35FBAWE	VWB35ABBWE	VWB35ABAWWE
400	64.6	MDV - 2A	VWB40FBBWE	VWB40FBAWE	VWB40ABBWE	VWB40ABAWWE
450	99.2	MDV - 3	VWB45FBBWE	VWB45FBAWE	VWB45ABBWE	VWB45ABAWWE
500	132.0	MDV - 3	VWB50FBBWE	VWB50FBAWE	VWB50ABBWE	VWB50ABAWWE
600	205.0	MDV - 4	VWB60FBBWE	VWB60FBAWE	VWB60ABBWE	VWB60ABAWWE
700	331.8	MDV - 4	VWB70FBBWE	VWB70FBAWE	VWB70ABBWE	VWB70ABAWWE
800	423.6	MDV - 5	VWB80FBBWE	VWB80FBAWE	VWB80ABBWE	VWB80ABAWWE
900	557.0	MDV - 6	VWB90FBBWE	VWB90FBAWE	VWB90ABBWE	VWB90ABAWWE
1000	659.0	MDV - 7	VWC10FBBWE	VWC10FBAWE	VWC10ABBWE	VWC10ABAWWE
1100	786.0	MDV - 7	VWC11FBBWE	VWC11FBAWE	VWC11ABBWE	VWC11ABAWWE
1200	1257.6	MDV - 8	VWC12FBBWE	VWC12FBAWE	VWC12ABBWE	VWC12ABAWWE

Wafer BV PFA25 bar DN 40-300 with MDV manual gear unit (CF8M stainless steel disk), change position 8 letter with "D".



REFERENCES AUMA ELECTRIC MOTORISED WAFER BV PFA10 bar

DN	PN	Auma Motor/gear unit	Auma Single-phase			Auma Three-phase		
			Weight (kg)	DI Disk + epoxy 150 µm	CF8M stainless steel disk	Weight (kg)	DI Disk + epoxy 150 µm	CF8M stainless steel disk
40	10/16	SG03.3	10,0	VWA40FMCWE	VWA40AMCWE	10,0	VWA40FECWE	VWA40AECWE
50	10/16	SG03.3	10,7	VWA50FMCWE	VWA50AMCWE	10,7	VWA50FECWE	VWA50AECWE
65	10/16	SG03.3	10,9	VWA65FMCWE	VWA65AMCWE	11,3	VWA65FECWE	VWA65AECWE
80	10/16	SG04.3	11,4	VWA80FMCWE	VWA80AMCWE	11,5	VWA80FECWE	VWA80AECWE
100	10/16	SG04.3	12,3	VWB10FMCWE	VWB10AMCWE	12,3	VWB10FECWE	VWB10AECWE
125	10/16	SG05.1	29,1	VWB12FMCWE	VWB12AMCWE	24,1	VWB12FECWE	VWB12AECWE
150	10/16	SG05.1	30,3	VWB15FMCWE	VWB15AMCWE	25,5	VWB15FECWE	VWB15AECWE
200	10	SG07.1	34,0	VWB20FMCWE	VWB20AMCWE	29,0	VWB20FECWE	VWB20AECWE
250	10	SG10.1	47,5	VWB25FMCWE	VWB25AMCWE	45,0	VWB25FECWE	VWB25AECWE
300	10	SG10.1	56,5	VWB30FMCWE	VWB30AMCWE	54,0	VWB30FECWE	VWB30AECWE
350	10	SG10.1	62,4	VWB35FMCWE	VWB35AMCWE	60,0	VWB35FECWE	VWB35AECWE
400	10	SG12.1	87,7	VWB40FMCWE	VWB40AMCWE	84,0	VWB40FECWE	VWB40AECWE
450	10	GS100.3/VZ4.3/SA07.2	124,0	VWB45FMCWE	VWB45AMCWE	141,0	VWB45FECWE	VWB45AECWE
500	10	GS100.3/VZ4.3/SA07.2	157,0	VWB50FMCWE	VWB50AMCWE	174,0	VWB50FECWE	VWB50AECWE
600	10	GS100.3/VZ4.3/SA07.6	231,0	VWB60FMCWE	VWB60AMCWE	231,6	VWB60FECWE	VWB60AECWE
700	10	GS125.3/VZ4.3/SA10.2	324,0	VWB70FMCWE	VWB70AMCWE	326,0	VWB70FECWE	VWB70AECWE
750	10	GS125.3/VZ4.3/SA10.2	366,0	VWB75FMCWE	VWB75AMCWE	368,0	VWB75FECWE	VWB75AECWE
800	10	GS125.3/VZ4.3/SA10.2	419,0	VWB80FMCWE	VWB80AMCWE	421,0	VWB80FECWE	VWB80AECWE
900	10	GS160.3/GZ160.3(8:1)/SA07.6	575,0	VWB90FMCWE	VWB90AMCWE	570,0	VWB90FECWE	VWB90AECWE
1000	10	GS160.3/GZ160.3(8:1)/SA10.2	698,0	VWC10FMCWE	VWC10AMCWE	699,0	VWC10FECWE	VWC10AECWE
1100	10	GS160.3/GZ160.3(8:1)/SA10.2	819,0	VWC11FMCWE	VWC11AMCWE	820,0	VWC11FECWE	VWC11AECWE
1200	10	GS200.3/GZ200.3(8:1)/SA10.2	1 156,0	VWC12FMCWE	VWC12AMCWE	1 154,0	VWC12FECWE	VWC12AECWE



REFERENCES BERNARD ELECTRIC MOTORISED WAFER BV PFA10 bar

DN	PN	Bernard Moteur/Gear unit	Bernard Single-phase			Bernard Three-phase		
			Weight (kg)	DI Disk + epoxy 150 µm	CF8M stainless steel disk	Weight (kg)	DI Disk + epoxy 150 µm	CF8M stainless steel disk
40	10/16	OA-6	7,7	VWA40FZCWE	VWA40AZCWE	8,5	VWA40FYCWE	VWA40AYCWE
50	10/16	OA-6	8,4	VWA50FZCWE	VWA50AZCWE	8,7	VWA50FYCWE	VWA50AYCWE
65	10/16	OA-6	9,0	VWA65FZCWE	VWA65AZCWE	10,0	VWA65FYCWE	VWA65AYCWE
80	10/16	OA-6	9,2	VWA80FZCWE	VWA80AZCWE	10,0	VWA80FYCWE	VWA80AYCWE
100	10/16	OA-6	11,0	VWB10FZCWE	VWB10AZCWE	10,2	VWB10FYCWE	VWB10AYCWE
125	10/16	OA-8	13,1	VWB12FZCWE	VWB12AZCWE	11,0	VWB12FYCWE	VWB12AYCWE
150	10/16	OA-15	14,5	VWB15FZCWE	VWB15AZCWE	13,1	VWB15FYCWE	VWB15AYCWE
200	10	OA15	18,0	VWB20FZCWE	VWB20AZCWE	14,5	VWB20FYCWE	VWB20AYCWE
250	10	ASP	36,0	VWB25FZCWE	VWB25AZCWE	18,0	VWB25FYCWE	VWB25AYCWE
300	10	AS-50	50,0	VWB30FZCWE	VWB30AZCWE	36,0	VWB30FYCWE	VWB30AYCWE
350	10	AS-80	57,0	VWB35FZCWE	VWB35AZCWE	50,0	VWB35FYCWE	VWB35AYCWE
400	10	AS-100	103,0	VWB40FZCWE	VWB40AZCWE	57,0	VWB40FYCWE	VWB40AYCWE
450	10	AS-200	145,0	VWB45FZCWE	VWB45AZCWE	103,0	VWB45FYCWE	VWB45AYCWE
500	10	AS-200	178,0	VWB50FZCWE	VWB50AZCWE	145,0	VWB50FYCWE	VWB50AYCWE
600	10	AS-400	237,6	VWB60FZCWE	VWB60AZCWE	178,0	VWB60FYCWE	VWB60AYCWE
700	10	AS-600	344,0	VWB70FZCWE	VWB70AZCWE	237,6	VWB70FYCWE	VWB70AYCWE
750	10	AS-1000	386,0	VWB75FZCWE	VWB75AZCWE	336,0	VWB75FYCWE	VWB75AYCWE
800	10	AS-1000	439,0	VWB80FZCWE	VWB80AZCWE	386,0	VWB80FYCWE	VWB80AYCWE
900	10	AS-1000	549,0	VWB90FZCWE	VWB90AZCWE	439,0	VWB90FYCWE	VWB90AYCWE
1000	10	ASM1+SBWG05-1-SDM	NC	VWC10FZCWE	VWC10AZCWE	549,0	VWC10FYCWE	VWC10AYCWE
1100	10	ASM2+SBWG55-1-SDM	NC	VWC11FZCWE	VWC11AZCWE	NC	VWC11FYCWE	VWC11AYCWE
1200	10	ASM2+SBWG55-1-SDM	NC	VWC12FZCWE	VWC12AZCWE	NC	VWC12FYCWE	VWC12AYCWE



REFERENCES AUMA ELECTRIC MOTORISED WAFER BV PFA16 bar

DN	PN	Auma Motor/gear unit	Auma Single-phase			Auma Three-phase		
			Weight (kg)	DI Disk + epoxy 150 µm	CF8M stainless steel disk	Weight (kg)	DI Disk + epoxy 150 µm	CF8M stainless steel disk
200	16	SG07.1	30,0	VWB20FMAWE	VWB20AMAWWE	29,0	VWB20FEAWE	VWB20AEAWE
250	16	SG10.1	46,0	VWB25FMAWE	VWB25AMAWWE	45,0	VWB25FEAWE	VWB25AEAWE
300	16	SG10.1	55,0	VWB30FMAWE	VWB30AMAWWE	54,0	VWB30FEAWE	VWB30AEAWE
350	16	SG12.1	65,0	VWB35FMAWE	VWB35AMAWWE	64,0	VWB35FEAWE	VWB35AEAWE
400	16	SG12.1	85,0	VWB40FMAWE	VWB40AMAWWE	84,0	VWB40FEAWE	VWB40AEAWE
450	16	GS100.3/VZ4.3/SA07.6	157,0	VWB45FMAWE	VWB45AMAWWE	142,0	VWB45FEAWE	VWB45AEAWE
500	16	GS100.3/VZ4.3/SA07.6	190,0	VWB50FMAWE	VWB50AMAWWE	175,0	VWB50FEAWE	VWB50AEAWE
600	16	GS100.3/VZ4.3/SA07.6	246,6	VWB60FMAWE	VWB60AMAWWE	231,6	VWB60FEAWE	VWB60AEAWE
700	16	GS125.3/VZ4.3/SA10.2	341,0	VWB70FMAWE	VWB70AMAWWE	326,0	VWB70FEAWE	VWB70AEAWE
750	16	GS125.3/VZ4.3/SA10.2	383,0	VWB75FMAWE	VWB75AMAWWE	368,0	VWB75FEAWE	VWB75AEAWE
800	16	GS160.3/GZ160.3(8:1)/SA10.2	481,0	VWB80FMAWE	VWB80AMAWWE	466,0	VWB80FEAWE	VWB80AEAWE
900	16	GS160.3/GZ160.3(8:1)/SA10.2	591,0	VWB90FMAWE	VWB90AMAWWE	576,0	VWB90FEAWE	VWB90AEAWE
1000	16	GS200.3/GZ200.3(8:1)/SA10.2	793,0	VWC10FMAWE	VWC10AMAWWE	778,0	VWC10FEAWE	VWC10AEAWE
1100	16	GS200.3/GZ200.3(16:1)/SA10.2	914,0	VWC11FMAWE	VWC11AMAWWE	899,0	VWC11FEAWE	VWC11AEAWE
1200	16	GS200.3/GZ200.3(16:1)/SA10.2	1 169,0	VWC12FMAWE	VWC12AMAWWE	1 154,0	VWC12FEAWE	VWC12AEAWE



REFERENCES BERNARD ELECTRIC MOTORISED WAFER BV PFA16 bar

DN	PN	Moteur/Gear unit Bernard	Bernard Single-phase			Bernard Three-phase		
			Weight (kg)	DI Disk + epoxy 150 µm	CF8M stainless steel disk	Weight (kg)	DI Disk + epoxy 150 µm	CF8M stainless steel disk
200	16	ASP	26,0	VWB20FZAWWE	VWB20AZAWWE	26,0	VWB20FYAWWE	VWB20AYAWWE
250	16	AS-50	41,0	VWB25FZAWWE	VWB25AZAWWE	41,0	VWB25FYAWWE	VWB25AYAWWE
300	16	AS-80	51,0	VWB30FZAWWE	VWB30AZAWWE	51,0	VWB30FYAWWE	VWB30AYAWWE
350	16	AS-100	83,0	VWB35FZAWWE	VWB35AZAWWE	83,0	VWB35FYAWWE	VWB35AYAWWE
400	16	AS-100	103,0	VWB40FZAWWE	VWB40AZAWWE	103,0	VWB40FYAWWE	VWB40AYAWWE
450	16	AS-200	145,0	VWB45FZAWWE	VWB45AZAWWE	145,0	VWB45FYAWWE	VWB45AYAWWE
500	16	AS-200	178,0	VWB50FZAWWE	VWB50AZAWWE	178,0	VWB50FYAWWE	VWB50AYAWWE
600	16	AS-400	237,6	VWB60FZAWWE	VWB60AZAWWE	237,6	VWB60FYAWWE	VWB60AYAWWE
700	16	AS-600	344,0	VWB70FZAWWE	VWB70AZAWWE	336,0	VWB70FYAWWE	VWB70AYAWWE
750	16	AS-1000	386,0	VWB75FZAWWE	VWB75AZAWWE	386,0	VWB75FYAWWE	VWB75AYAWWE
800	16	AS-1000	439,0	VWB80FZAWWE	VWB80AZAWWE	439,0	VWB80FYAWWE	VWB80AYAWWE
900	16	ASM1+SBWG05-1-SDM	NC	VWB90FZAWWE	VWB90AZAWWE	NC	VWB90FYAWWE	VWB90AYAWWE
1000	16	ASM2+SBWG55-1-SDM	NC	VWC10FZAWWE	VWC10AZAWWE	NC	VWC10FYAWWE	VWC10AYAWWE
1100	16	ASM2+SBWG55-1-SDM	NC	VWC11FZAWWE	VWC11AZAWWE	NC	VWC11FYAWWE	VWC11AYAWWE
1200	16	ST70+SBWG55-1-SM	NC	VWC12FZAWWE	VWC12AZAWWE	NC	VWC12FYAWWE	VWC12AYAWWE



REFERENCES AUMA ELECTRIC MOTORISED WAFER BV PFA25 bar

DN 40-300 CF8M stainless steel disk, change position 8 letter with "D".

REFERENCES BERNARD ELECTRIC MOTORISED WAFER BV PFA25 bar

DN 40-300 CF8M stainless steel disk, change position 8 letter with "D".

REFERENCES PNEUMATIC MOTORISED WAFER BV

- Spring return: DN40-150 PFA10/16 bar and DN200-500 PFA10 bar, change position 7 letter with "X"
- Double effect: DN40-150 PFA10/16 bar and DN200-600 PFA10 bar, change position 7 letter with "P"



Diagram provided for information only. Saint-Gobain PAM shall not be liable for the wrong use of information included in this diagram.

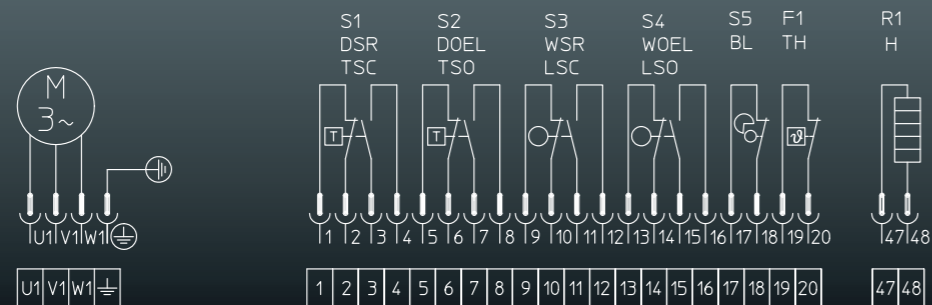

Lug BV dimensions and references

- The Lug Butterfly Valve is manufactured for a range of diameters from DN 40 to DN 1000 mm.
- The connection between flanges of the network is made with screws located on each side of the BV and screwed to the body of the valve. This assembly allows dismantling the valve from one side of the installation while keeping the other side pressurised and fully operational. This Lug BV offers greater simplification during the time of assembly that requires isolating the line temporarily, as well as for removing pumps, tanks, boat shells, etc.



DN	Manual				Motorised				Pneumatic	
	Lever based		Gear unit based		Electric				Double effect	Spring return
	DI Disk	Stainless Steel disk	DI Disk	Stainless Steel disk	Auma		Bernard			
DI Disk	Stainless Steel disk	DI Disk	Stainless Steel disk	DI Disk	Stainless Steel disk	DI Disk	Stainless Steel disk	Double effect	Spring return	
40										
50										
60-65	PN10/ PN16	PN25	PN10/ PN16	PN25	PN10/ PN16	PN25	PN10/ PN16	PN25	PN10/ PN16	PN10/ PN16
80										
100										
125										
150										
200										
250	PN10	PN10	PN10 and PN16	PN25	PN10 and PN16	PN25	PN10 and PN16	PN25	PN10 and PN16	PN16
300										
350										
400										
450										
500										
600										
700										
800										
900										
1000										

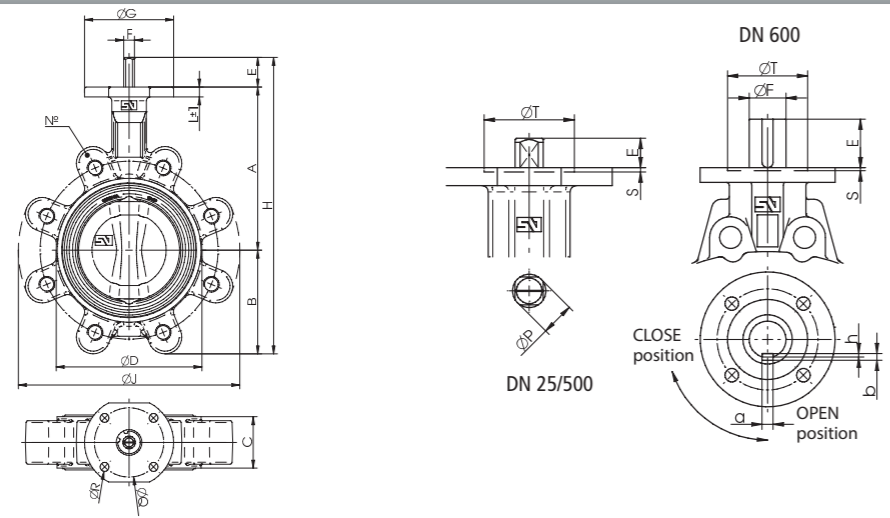

SIZE LUG BV BARE SHAFT

DN		General dimensions												
mm	Inches	ISO	N°	A	B	C	D	E	F	G	H	J	L	Weight
40	1 1/2"	F-07	4	110	54	33	76	30	11	90	194	140	10	2
50	2"	F-07	4	120	59.5	43	100	30	11	90	209.5	156	10	2.9
65 (*)	2 1/2"	F-07	4	135	66.5	46	108	30	11	90	231.5	175	10	3.3
65	2 1/2"	F-07	8	135	82	46	108	30	11	90	247	175	10	4
80 (*)	3"	F-07	8	141	91	46	124	30	11	90	262	194	10	4.8
80	3"	F-07	4	141	75	46	124	30	11	90	246	185	10	3.5
100	4"	F-07	8	165	105	52	147.3	30	11	90	300	224	10	6.3
125	5"	F-07	8	180	125	56	180	33	14	90	338	267	12	9.8
150	6"	F-07	8	193	136.5	56	206.5	33	14	90	362.5	292	12	10.5
200 (*)	8"	F-07	8	225	156	60	257	33	17	90	414	334	12	13.9
200	8"	F-07	12	225	171	60	257	33	17	90	429	352	12	17.5
250	10"	F-10	12	282.5	210	68	324	23	22	130	515.5	409	14	26.6
300	12"	F-10	12	308	240	78	383	23	22	130	571	480	14	39.5
350 (*)	14"	F-10	16	338.5	263	78	437	31	22	160	632.5	522	18	56
350	14"	F-10	12	338.5	263	78	437	31	22	160	632.5	522	18	55.5
400	16"	F-12	16	380	308	102	486	31	27	160	719	595	17	73.6
450 (*)	18"	F-14	20	380.5	340	114	538	38	36	190	758.5	633	20	103
450	18"	F-14	16	380.5	340	114	538	38	36	190	758.5	633	20	96.3
500	20"	F-14	20	432.5	380	127	586	38	36	210	850.5	717	20	149
600	24"	F-16	20	494	440	154	690	80	60	210	1014	833	24	215
700	28"	F-25	24	590	490	165	832	106	65	300	1186	904	30	287
800	32"	F-25	24	630	565	190	902	106	80	300	1301	1020	28	406
1000	40"	F-25	28	770	675	216	1116	110	80	350	1555	1246	32	672

Dimensions in mm, weight in kg.
(*) PN10 Standard. DN 750 and DN 900: contact us.

SIZE LUG BV WITH HANDLEVER

"MN" TYPE

DN		handler								
mm	Inches	Standard	C	X	E2	H2	Y2	L2	M2	Weight
40	1 1/2"	PN.10-16-ANSI 150	33	76	49	150	213	220	90	2.4
50	2"	PN.10-16-ANSI 150	43	100	49	169	228	220	90	3.3
65 (*)	2 1/2"	PN.10-16-ANSI 150	46	108	49	184	250	220	90	3.7
65	2 1/2"	PN.16-EN.1092.1	46	108	49	184	200	220	90	4.4
80 (*)	3"	PN.10-16	46	124	60	201	292	260	90	5.2
80	3"	ANSI 150	46	124	60	201	276	260	90	3.9
100	4"	PN.10-16-ANSI 150	52	147	60	225	330	260	90	6.8
125	5"	PN.10-16-ANSI 150	56	180	75	255	380	315	90	10.3
150	6"	PN.10-16-ANSI 150	56	206	75	268	404	315	90	10.9
200 (*)	8"	PN.10-ANSI 150	60	257	75	300	456	315	90	14.5
200		PN.16	60	257	75	300	471	315	90	18.1

Dimensions in mm, weight in kg.

ANSI 150 = PN20.

(*) PN10 Standard.

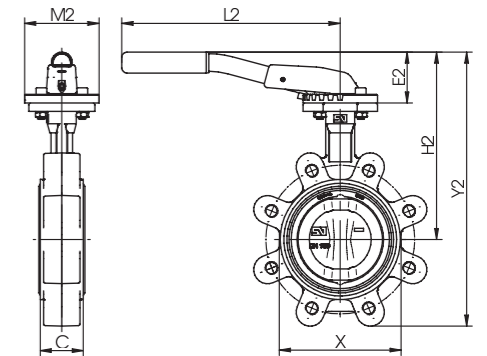

"MR" TYPE

DN		handler								
mm	Inches	Standard	C	X	E3	H3	Y3	L3	M3	Weight
40	1 1/2"	PN.10-16-ANSI 150	33	76	115	225	279	260	90	2.6
50	2"	PN.10-16-ANSI 150	43	100	115	235	294	260	90	3.5
65 (*)	2 1/2"	PN.10-16-ANSI 150	46	108	115	250	316	260	90	3.9
65	2 1/2"	PN.16-EN.1092.1	46	108	115	250	332	260	90	4.6
80 (*)	3"	PN.10-16	46	124	115	256	347	260	90	5.3
80	3"	ANSI 150	46	124	115	256	331	260	90	4
100	4"	PN.10-16-ANSI 150	52	147	115	280	385	260	90	6.9
125	5"	PN.10-16-ANSI 150	56	180	115	295	420	310	90	10.5
150	6"	PN.10-16-ANSI 150	56	206	115	308	444	310	90	11.2
200 (*)	8"	PN.10-ANSI 150	60	257	115	340	496	310	90	14.6
200		PN.16	60	257	115	340	511	310	90	18.2
250	10"	PN.10-16-ANSI 150	68	324	120	402	612	500	130	28.2
300	12"	PN.10-16-ANSI 150	78	383	120	428	668	500	130	41.2
350 (*)	14"	PN.10-16	78	437	120	458	722	500	130	57.7
350	14"	ANSI 150	78	437	120	458	722	500	130	57.2

Dimensions in mm, weight in kg.

ANSI 150 = PN20.

(*) PN10 Standard.

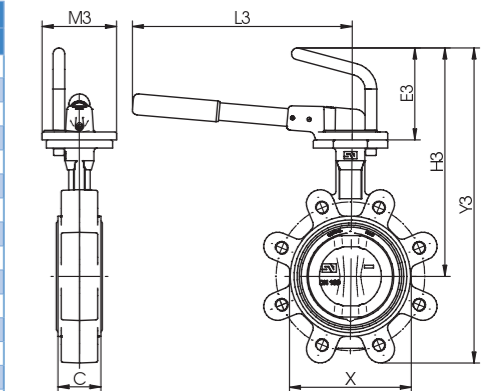

SIZE RAP LUG GEARBOX MANUAL HANDWHEEL

DN		Gear unit type MDV with volant										
mm	Inches	Standard	C	X	Model	E4	H4	Y4	L4	M4	N	Weight
40	1 1/2"	PN.10-16-ANSI 150	33	76	MDV - 0	125	198	252	128	43.5	50	3.2
50	2"	PN.10-16-ANSI 150	43	100	MDV - 0	125	208	267	128	43.5	50	4.1
65 (*)	2 1/2"	PN.10-16-ANSI 150	46	108	MDV - 0	125	223	289	128	43.5	50	4.5
65	2 1/2"	PN.16-EN.1092.1	46	108	MDV - 0	125	223	305	128	43.5	50	5.2
80 (*)	3"	PN.10-16	46	124	MDV - 0	125	229	320	128	43.5	50	5.9
80	3"	ANSI 150	46	124	MDV - 0	125	229	304	128	43.5	50	4.6
100	4"	PN.10-16-ANSI 150	52	147	MDV - 0	125	253	358	128	43.5	50	7.6
125	5"	PN.10-16-ANSI 150	56	180	MDV - 1	160	286	411	135	43.5	50	11.2
150	6"	PN.10-16-ANSI 150	56	206	MDV - 1	160	298	434	135	43.5	50	12.0
200 (*)	8"	PN.10-ANSI 150	60	257	MDV - 1A	200	355	511	152	52.5	57	16.5
200	8"	PN.16	60	257	MDV - 1A	200	355	526	152	52.5	57	20.1
250	10"	PN.10-16-ANSI 150	68	324	MDV - 2	250	442	652	222	61	70	30.0
300	12"	PN.10-16-ANSI 150	78	383	MDV - 2	250	468	708	222	61	70	43.0
350 (*)	14"	PN.10-16	78	437	MDV - 2	250	498	761	222	61	70	59.6
350	14"	ANSI 150	78	437	MDV - 2	250	498	761	222	61	70	59.1
400	16"	PN.10-16-ANSI 150	102	486	MDV - 2A	300	572	880	278	69	72.5	83.6
450	18"	PN.10-16	114	538	MDV - 3	400	630	970	321	96.5	91.5	122.0
450 (*)	18"	ANSI 150	114	538	MDV - 3	400	630	970	321	96.5	91.5	115.3
500	20"	PN.10-16-ANSI 150	127	586	MDV - 3	400	682	1062	321	96.5	91.5	167.0
600	24"	PN.10-16-ANSI 150	154	690	MDV - 4	500	799	1239	408	137.5	140	250.0

Dimensions in mm, weight in kg.

ANSI 150 = PN20

(*) PN10 Standard.

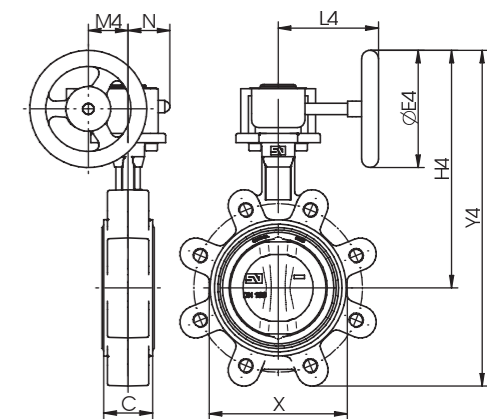

SIZE AUMA ELECTRIC MOTORISED LUG BV PFA10 bar

DN		Gear unit and servomotor mechanism	Dimensions						Weight (kg)
mm	Inches		A3	B3	C3	D3	E3	H3	
40	1 1/2"	SG 03.3	92	210	207	215	119	320	10.3
50	2"	SG 03.3	92	210	207	215	119	327	11.2
65	2 1/2"	SG 03.3	92	210	207	215	119	342	11.6
80	3"	SG 04.3	92	210	207	215	119	348	13.1
100	4"	SG 04.3	92	210	207	215	119	372	14.6
125	5"	SG05.1	63	238	344	265	186	524	27.8
150	6"	SG05.1	63	238	344	265	186	537	28.5
200	8"	SG07.1	63	238	344	265	186	569	31.9
250	10"	SG10.1	80	248	361	265	191	643.5	50.6
300	12"	SG10.1	80	248	361	265	191	669	63.5
350	14"	SG10.1	80	248	361	265	191	699.5	80.0
400	16"	SG12.1	105	248	385	265	191	765	102.6
450	18"	GS100.3/VZ4.3/SA07.2	112.5	255	447	265	216	827.5	170
500	20"	GS100.3/VZ4.3/SA07.2	112.5	255	447	265	216	879.5	216
600	24"	GS100.3/VZ4.3 + SA07.6	547	189	313	164	287	807	291
700	28"	GS125.3/VZ4.3 + SA10.2	554	194	323	158	316	913	376
800	32"	GS125.3/VZ4.3 + SA10.2	554	194	323	158	316	953	491
1000	40"	GS160.3/GZ160.3(8:1) + SA10.2	630	290	323	165	351	1093	798

Dimensions in mm, weight in kg.

DN 750 and 900: contact us.

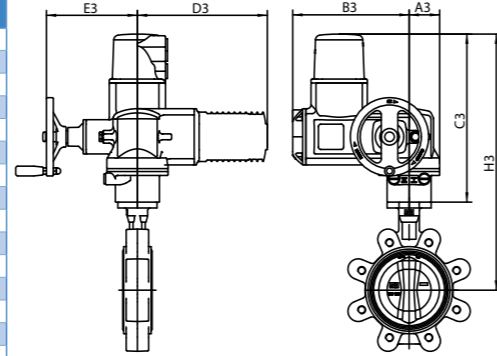

References correspond to the Lug type BV with ductile cast iron body EN GJS-400-15 + RAL 5005 min. 150 microns powder coated epoxy and sleeve/joint in EPDM elastomer with ACS. Contact us for other materials.

For other types of sleeve materials, change the letter in position 10 of the reference: N=Nitrile, W=EPDM DVGW, V=Viton.

REFERENCES LUG BV PFA16 bar BARE SHAFT

DN	Weight (kg)	DI butterfly + black epoxy powder 150 µ		CF8M stainless steel disk	
		PN10/16	PN10	PN16	PN10
40	2.00		VLA40FACWE		VLA40AACWE
50	2.90		VLA50FACWE		VLA50AACWE
65	3.30		VLA65FACWE		VLA65AACWE
80	4.80		VLA80FACWE		VLA80AACWE
100	6.30		VLB10FACWE		VLB10AACWE
125	9.80		VLB12FACWE		VLB12AACWE
150	10.50		VLB15FACWE		VLB15AACWE
200	13.90	VLB20FABWE	VLB20FAAWE	VLB20AABWE	VLB20AAAWE
250	26.60	VLB25FABWE	VLB25FAAWE	VLB25AABWE	VLB25AAAWE
300	39.50	VLB30FABWE	VLB30FAAWE	VLB30AABWE	VLB30AAAWE
350	56.00	VLB35FABWE	VLB35FAAWE	VLB35AABWE	VLB35AAAWE
400	73.60	VLB40FABWE	VLB40FAAWE	VLB40AABWE	VLB40AAAWE
450	103.00	VLB45FABWE	VLB45FAAWE	VLB45AABWE	VLB45AAAWE
500	149.00	VLB50FABWE	VLB50FAAWE	VLB50AABWE	VLB50AAAWE
600	215.00	VLB60FABWE	VLB60FAAWE	VLB60AABWE	VLB60AAAWE
700	287.00	VLB70FABWE	VLB70FAAWE	VLB70AABWE	VLB70AAAWE
800	406.00	VLB80FABWE	VLB80FAAWE	VLB80AABWE	VLB80AAAWE
1000	672.00	VLC10FABWE	VLC10FAAWE	VLC10AABWE	VLC10AAAWE



Lug BV PFA25 bar DN 40-300 (CF8M stainless steel disk), change position 8 letter with "D".

DN 900: contact us.

SIZE AUMA ELECTRIC MOTORISED LUG BV PFA16 bar

DN		Gear unit and servomotor mechanism	Dimensions						Weight (kg)
mm	Inches		A3	B3	C3	D3	E3	H3	
200	8"	SG07.1	63	238	344	265	186	569	37.0
250	10"	SG10.1	80	248	361	265	191	643.5	54.1
300	12"	SG10.1	80	248	361	265	191	669	66.5
350	14"	SG10.1	105	248	385	265	191	723.5	88.0
400	16"	SG12.1	105	248	385	265	191	765	106
450	18"	GS100.3/VZ4.3/SA07.2	112.5	255	447	265	216	827.5	146
500	20"	GS100.3/VZ4.3/SA07.2	112.5	255	447	265	216	879.5	192
600	24"	GS100.3/VZ4.3 + SA07.6	547	189	313	164	287	807	275
700	28"	GS125.3/VZ4.3 + SA10.2	554	194	323	158	316	913	360
800	32"	GS160.3/GZ160.3(8:1) + SA10.2	630	290	323	165	351	953	521
1000	40"	GS200.3/GZ200.3(8:1) + SA10.2	760	366	338	208	391	1108	869

Dimensions in mm, weight in kg.

DN 750 and 900: contact us.

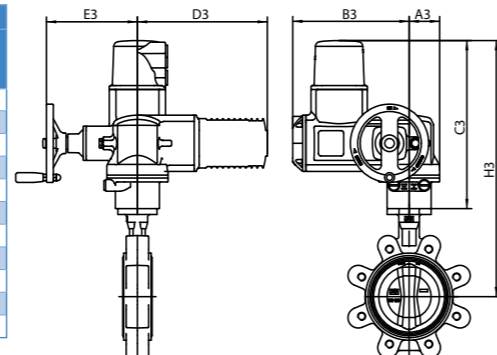

REFERENCES LUG BV PFA16 bar MANUAL WITH HANDLEVER

DN	Type	Weight (kg)	DI butterfly + black epoxy powder 150 µ		CF8M stainless steel butterfly disk	
			PN10/16	PN10	PN16	PN10
40	MN	2.4		VLA40FLCWE		VLA40ALCWE
50	MN	3.3		VLA50FLCWE		VLA50ALCWE
65	MN	3.7		VLA65FLCWE		VLA65ALCWE
80	MN	5.2		VLA80FLCWE		VLA80ALCWE
100	MN	6.8		VLB10FLCWE		VLB10ALCWE
125	MN	10.3		VLB12FLCWE		VLB12ALCWE
150	MN	10.9		VLB15FLCWE		VLB15ALCWE
200	MR	14.5	VLB20FLBWE	VLB20FLAWE	VLB20ALBWE	VLB20ALAWWE
250	MR	28.2	VLB25FLBWE	VLB25FLAWE	VLB25ALBWE	VLB25ALAWWE
300	MR	41.2	VLB30FLBWE	VLB30FLAWE	VLB30ALBWE	VLB30ALAWWE



Lug BV PFA25 bar DN 40-100 (CF8M stainless steel disk), change position 8 letter with "D".

Contact us for MR lever DN40-150.

Contact us for dimensions of Lug BV with Bernard motorisation.

REFERENCES LUG BV PFA16 bar MANUAL HANDWELL WITH MDV GEARBOX

DN	Gear unit		Weight (kg)	DI butterfly + black epoxy powder 150 µ		CF8M stainless steel disk	
	PN10	PN16		PN10/16	PN10	PN16	PN10
40	MDV-0		3.2	VLA40FBCWE		VLA40ABCWE	
50	MDV-0		4.1	VLA50FBCWE		VLA50ABCWE	
65	MDV-0		4.5	VLA65FBCWE		VLA65ABCWE	
80	MDV-0		5.9	VLA80FBCWE		VLA80ABCWE	
100	MDV-0		7.6	VLB10FBCWE		VLB10ABCWE	
125	MDV-1		11.2	VLB12FBCWE		VLB12ABCWE	
150	MDV-1		12.0	VLB15FBCWE		VLB15ABCWE	
200	MDV-1A		16.5	VLB20FBBWE	VLB20FBAWE	VLB20ABBWE	VLB20ABAWWE
250	MDV-2		30.0	VLB25FBBWE	VLB25FBAWE	VLB25ABBWE	VLB25ABAWWE
300	MDV-2		43.0	VLB30FBBWE	VLB30FBAWE	VLB30ABBWE	VLB30ABAWWE
350	MDV-2		59.6	VLB35FBBWE	VLB35FBAWE	VLB35ABBWE	VLB35ABAWWE
400	MDV-2A		83.6	VLB40FBBWE	VLB40FBAWE	VLB40ABBWE	VLB40ABAWWE
450	MDV-3		122.0	VLB45FBBWE	VLB45FBAWE	VLB45ABBWE	VLB45ABAWWE
500	MDV-3		167.0	VLB50FBBWE	VLB50FBAWE	VLB50ABBWE	VLB50ABAWWE
600	MDV-4		250.0	VLB60FBBWE	VLB60FBAWE	VLB60ABBWE	VLB60ABAWWE
700	MDV-4	MDV-5	367.0	VLB70FBBWE	VLB70FBAWE	VLB70ABBWE	VLB70ABAWWE
800	MDV-5	MDV-6	482.0	VLB80FBBWE	VLB80FBAWE	VLB80ABBWE	VLB80ABAWWE
1000	MDV-7		744.0	VLC10FBBWE	VLC10FBAWE	VLC10ABBWE	VLC10ABAWWE



Lug BV PFA25 bar DN 40-300 (CF8M stainless steel disk), change position 8 letter with "D".

DN 900: contact us.

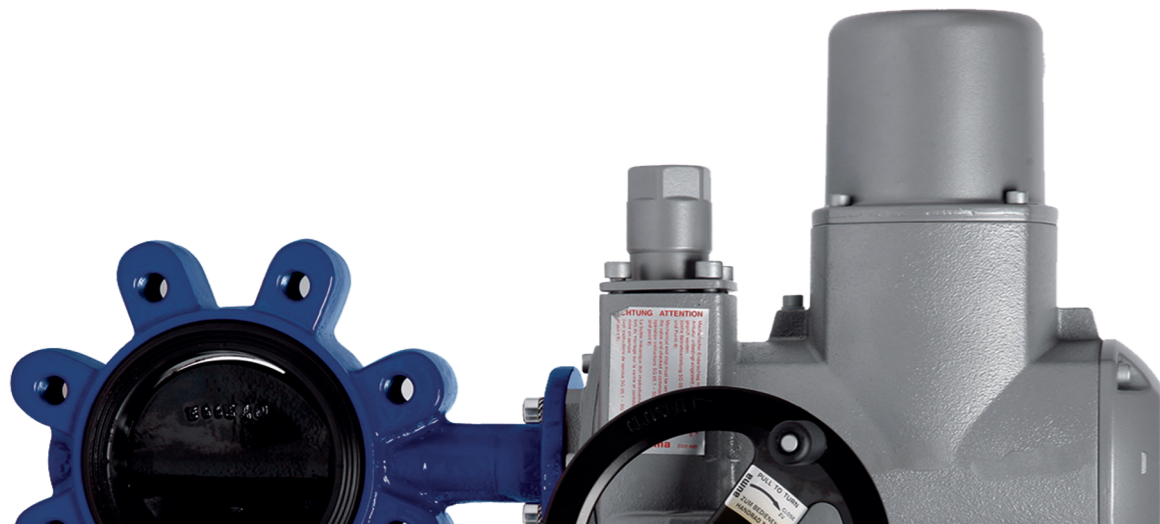

REFERENCES AUMA ELECTRIC MOTORISED LUG BV PFA10 bar

DN	PN	Moteur / Gear unit Auma	Auma Single-phase			Auma Three-phase		
			Weight (kg)	DI Disk + epoxy 150 µm	CF8M stainless steel disk	Weight (kg)	DI Disk + epoxy 150 µm	CF8M stainless steel disk
40	10/16	SG03.3	10.3	VLA40FMCWE	VLA40AMCWE	10.3	VLA40FECWE	VLA40AECWE
50	10/16	SG03.3	11.2	VLA50FMCWE	VLA50AMCWE	11.2	VLA50FECWE	VLA50AECWE
65	10/16	SG03.3	11.6	VLA65FMCWE	VLA65AMCWE	11.6	VLA65FECWE	VLA65AECWE
80	10/16	SG04.3	13.1	VLA80FMCWE	VLA80AMCWE	13.1	VLA80FECWE	VLA80AECWE
100	10/16	SG04.3	14.6	VLB10FMCWE	VLB10AMCWE	14.6	VLB10FECWE	VLB10AECWE
125	10/16	SG05.1	27.8	VLB12FMCWE	VLB12AMCWE	27.8	VLB12FECWE	VLB12AECWE
150	10/16	SG05.1	28.5	VLB15FMCWE	VLB15AMCWE	28.5	VLB15FECWE	VLB15AECWE
200	10	SG07.1	31.9	VLB20FMCWE	VLB20AMCWE	31.9	VLB20FECWE	VLB20AECWE
250	10	SG10.1	50.6	VLB25FMCWE	VLB25AMCWE	50.6	VLB25FECWE	VLB25AECWE
300	10	SG10.1	63.5	VLB30FMCWE	VLB30AMCWE	63.5	VLB30FECWE	VLB30AECWE
350	10	SG10.1	80.0	VLB35FMCWE	VLB35AMCWE	80.0	VLB35FECWE	VLB35AECWE
400	10	SG12.1	102.6	VLB40FMCWE	VLB40AMCWE	102.6	VLB40FECWE	VLB40AECWE
450	10	GS100.3/VZ4.3/SA07.2	170.0	VLB45FMCWE	VLB45AMCWE	163.0	VLB45FECWE	VLB45AECWE
500	10	GS100.3/VZ4.3/SA07.2	216.0	VLB50FMCWE	VLB50AMCWE	209.0	VLB50FECWE	VLB50AECWE
600	10	GS100.3/VZ4.3/SA07.6	291.0	VLB60FMCWE	VLB60AMCWE	276.0	VLB60FECWE	VLB60AECWE
700	10	GS125.3/VZ4.3/SA10.2	376.0	VLB70FMCWE	VLB70AMCWE	361.0	VLB70FECWE	VLB70AECWE
800	10	GS125.3/VZ4.3/SA10.2	491.0	VLB80FMCWE	VLB80AMCWE	476.0	VLB80FECWE	VLB80AECWE
1000	10	GS160.3/GZ160.3(8:1)/SA10.2	798.0	VLC10FMCWE	VLC10AMCWE	783.0	VLC10FECWE	VLC10AECWE



DN 900: contact us.

REFERENCES AUMA ELECTRIC MOTORISED LUG BV PFA16 bar

DN	PN	Moteur / Gear unit Auma	Auma Single-phase			Auma Three-phase		
			Weight (kg)	DI Disk + epoxy 150 µm	CF8M stainless steel disk	Weight (kg)	DI Disk + epoxy 150 µm	CF8M stainless steel disk
200	16	SG07.1	32.9	VLB20FMAWE	VLB20AMAWE	31.9	VLB20FEAWE	VLB20AEAWE
250	16	SG10.1	51.6	VLB25FMAWE	VLB25AMAWE	50.6	VLB25FEAWE	VLB25AEAWE
300	16	SG10.1	64.5	VLB30FMAWE	VLB30AMAWE	63.5	VLB30FEAWE	VLB30AEAWE
350	16	SG12.1	85.0	VLB35FMAWE	VLB35AMAWE	84.0	VLB35FEAWE	VLB35AEAWE
400	16	SG12.1	102.6	VLB40FMAWE	VLB40AMAWE	101.6	VLB40FEAWE	VLB40AEAWE
450	16	GS100.3/VZ4.3/SA07.6	179.0	VLB45FMAWE	VLB45AMAWE	164.0	VLB45FEAWE	VLB45AEAWE
500	16	GS100.3/VZ4.3/SA07.6	225.0	VLB50FMAWE	VLB50AMAWE	210.0	VLB50FEAWE	VLB50AEAWE
600	16	GS100.3/VZ4.3/SA07.6	291.0	VLB60FMAWE	VLB60AMAWE	276.0	VLB60FEAWE	VLB60AEAWE
700	16	GS125.3/VZ4.3/SA10.2	376.0	VLB70FMAWE	VLB70AMAWE	361.0	VLB70FEAWE	VLB70AEAWE
800	16	GS160.3/GZ160.3(8:1)/SA10.2	536.0	VLB80FMAWE	VLB80AMAWE	521.0	VLB80FEAWE	VLB80AEAWE
1000	16	GS200.3/GZ200.3(8:1)/SA10.2	877.0	VLC10FMAWE	VLC10AMAWE	862.0	VLC10FEAWE	VLC10AEAWE



Electric motorised Lug BV AUMA PFA25 bar DN 40-300 (CF8M stainless steel disk), change position 8 letter with "D".

DN 900: contact us.

REFERENCES BERNARD ELECTRIC MOTORISED LUG BV PFA10 bar

DN	PN	Moteur / Gear unit Bernard	Bernard Single-phase			Bernard Three-phase		
			Weight (kg)	DI Disk + epoxy 150 µm	CF8M stainless steel disk	Weight (kg)	DI Disk + epoxy 150 µm	CF8M stainless steel disk
40	10/16	OA-6	8.0	VLA40FZCWE	VLA40AZCWE	9.0	VLA40FYCWE	VLA40AYCWE
50	10/16	OA-6	8.9	VLA50FZCWE	VLA50AZCWE	9.9	VLA50FYCWE	VLA50AYCWE
65	10/16	OA-6	9.3	VLA65FZCWE	VLA65AZCWE	10.3	VLA65FYCWE	VLA65AYCWE
80	10/16	OA-6	10.8	VLA80FZCWE	VLA80AZCWE	11.8	VLA80FYCWE	VLA80AYCWE
100	10/16	OA-6	13.3	VLB10FZCWE	VLB10AZCWE	13.3	VLB10FYCWE	VLB10AYCWE
125	10/16	OA-6	16.8	VLB12FZCWE	VLB12AZCWE	16.8	VLB12FYCWE	VLB12AYCWE
150	10/16	OA-6	17.5	VLB15FZCWE	VLB15AZCWE	17.5	VLB15FYCWE	VLB15AYCWE
200	10	OA-8	20.9	VLB20FZBWE	VLB20AZBWE	20.9	VLB20FYBWE	VLB20AYBWE
250	10	OA-15	41.6	VLB25FZBWE	VLB25AZBWE	41.6	VLB25FYBWE	VLB25AYBWE
300	10	OA15	59.5	VLB30FZBWE	VLB30AZBWE	59.5	VLB30FYBWE	VLB30AYBWE
350	10	ASP	77.0	VLB35FZBWE	VLB35AZBWE	77.0	VLB35FYBWE	VLB35AYBWE
400	10	AS-50	120.6	VLB40FZBWE	VLB40AZBWE	120.6	VLB40FYBWE	VLB40AYBWE
450	10	AS-80	167.0	VLB45FZBWE	VLB45AZBWE	167.0	VLB45FYBWE	VLB45AYBWE
500	10	AS-100	213.0	VLB50FZBWE	VLB50AZBWE	213.0	VLB50FYBWE	VLB50AYBWE
600	10	AS-200	282.0	VLB60FZBWE	VLB60AZBWE	282.0	VLB60FYBWE	VLB60AYBWE
700	10	AS-200	379.0	VLB70FZBWE	VLB70AZBWE	371.0	VLB70FYBWE	VLB70AYBWE
800	10	AS-400	NC	VLB80FZBWE	VLB80AZBWE	NC	VLB80FYBWE	VLB80AYBWE
1000	10	AS-600	494.0	VLC10FZBWE	VLC10AZBWE	494.0	VLC10FYBWE	VLC10AYBWE



Electric motorised Lug BV BERNARD PFA25 bar DN 40-300 (CF8M stainless steel disk), change position 8 letter with "D".

DN 750 and DN 900: contact us.

REFERENCES BERNARD ELECTRIC MOTORISED LUG BV PFA16 bar

DN	PN	Moteur / Gear unit Bernard	Bernard Single-phase			Bernard Three-phase		
			Weight (kg)	DI Disk + epoxy 150 µm	CF8M stainless steel disk	Weight (kg)	DI Disk + epoxy 150 µm	CF8M stainless steel disk
200	16	ASP	28.9	VLB20FZAWE	VLB20AZAWE	28.9	VLB20FYAWE	VLB20AYAWE
250	16	AS-50	46.6	VLB25FZAWE	VLB25AZAWE	46.6	VLB25FYAWE	VLB25AYAWE
300	16	AS-80	60.5	VLB30FZAWE	VLB30AZAWE	60.5	VLB30FYAWE	VLB30AYAWE
350	16	AS-100	103.0	VLB35FZAWE	VLB35AZAWE	103.0	VLB35FYAWE	VLB35AYAWE
400	16	AS-100	120.6	VLB40FZAWE	VLB40AZAWE	120.6	VLB40FYAWE	VLB40AYAWE
450	16	AS-200	167.0	VLB45FZAWE	VLB45AZAWE	167.0	VLB45FYAWE	VLB45AYAWE
500	16	AS-200	213.0	VLB50FZAWE	VLB50AZAWE	213.0	VLB50FYAWE	VLB50AYAWE
600	16	AS-400	282.0	VLB60FZAWE	VLB60AZAWE	282.0	VLB60FYAWE	VLB60AYAWE
700	16	AS-600	379.0	VLB70FZAWE	VLB70AZAWE	371.0	VLB70FYAWE	VLB70AYAWE
750	16	AS-1000	NC	VLB75FZAWE	VLB75AZAWE	NC	VLB75FYAWE	VLB75AYAWE
800	16	AS-1000	494.0	VLB80FZAWE	VLB80AZAWE	494.0	VLB80FYAWE	VLB80AYAWE
1000	16	ASM2+SBWG55-1-SDM	NC	VLC10FZAWE	VLC10AZAWE	NC	VLC10FYAWE	VLC10AYAWE



Electric motorised Lug BV BERNARD PFA25 bar DN 40-300 (CF8M stainless steel disk), change position 8 letter with "D".

DN 750 and DN 900: contact us.

REFERENCES PNEUMATIC MOTORISED LUG BV

- Spring return: DN40-150 PFA10/16 bar and DN200-500 PFA10 bar, change position 7 letter with "X"
- Double effect: DN40-150 PFA10/16 bar and DN200-600 PFA10 bar, change position 7 letter with "P"



APPLICATIONS

- For mounting on the Wafer and Lug concentric BV range, in diameters DN 40 to DN 350mm.



RANGE

"MN" TYPE LEVER DN 40 to DN 200 mm

- "MN-S" single DN 40-150
- "MN-C" with lock DN 40-200
In case of locking of the lever position.

"MR" TYPE LEVER DN 40 to DN 350 mm

- "MR-1" DN 40-200
- "MR-2" DN 250-350

DN	"MN" Type		"MR" Type	
	MN-S	MN-C	MR-1	MR-2
40-200				
250-350				

"MN" TYPE LEVER FOR DN 40 TO DN 200 MM

No.	Description	Material	Parts
1	Lever head	Aluminium + epoxy	1
2	Lever arm	Steel pipe + epoxy	1
3	Spring	Stainless steel AISI 302	1
4	Coverage	Vinyl	1
5	Final flange	Reinforced polyamide	1
6	Elastic bar	Carbon steel	1
7	ALLEN tie DIN 916	Galvanised steel	1
8	Screw C/ ALLEN DIN 912 + nut DIN 934	Galvanised steel	1
9 (*)	Padlock	Brass	1

(*) only for model "MN-C".

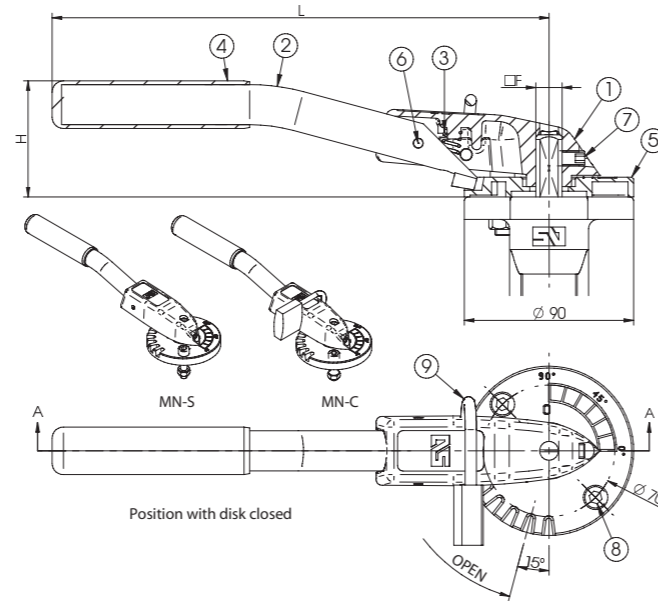

Dimensions and weights

DN	F (mm)	L (mm)	H (mm)	Weight (kg)	
				MN-S	MN-C
40-65	11	220	49	0,4	0,7
80-100	11	260	60	0,45	0,75
125-150	14	315	75	0,55	0,85
200	17	315	75	0,55	0,85

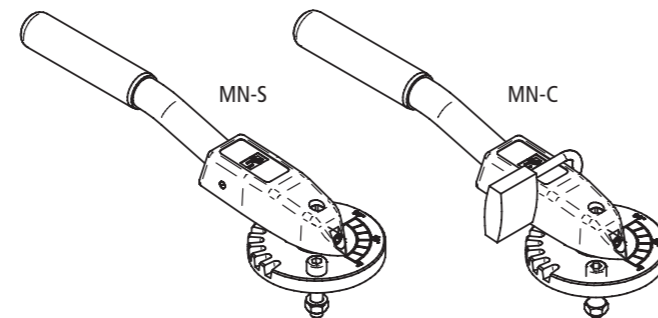

It is recommended to use the manual gearbox from DN 200 mm onwards.

The range of levers is made of "MN" and "MR" types:

- The "MN" type is with 90° square recess as per DIN 3337. Notching every 15° with seven position.
- The "MR" type is 90° square as per DIN 3337. Lever adjustable from all positions.

"MR" TYPE LEVER FOR DN 40 TO DN 350MM

"MR-1" TYPE LEVER: DN 40 TO DN 200MM

Material

No.	Description	Material	Parts
1	Lever head	Aluminium + epoxy	1
2	Lever arm	Tube en Steel + epoxy	1
3	Coverage	Vinyl	1
4	Blocking lever	Stainless steel AISI 420	1
5	Elastic bar	Carbon steel	1
6	ALLEN tie DIN 916	Galvanised steel	1
7	Screw C/ ALLEN DIN 912 + nut DIN 934	Galvanised steel	1

Dimensions and Weights

DN	F (mm)	L (mm)	Weight (kg)
	40-100	11	260
125-150	14	310	0,7
200	17	310	0,7

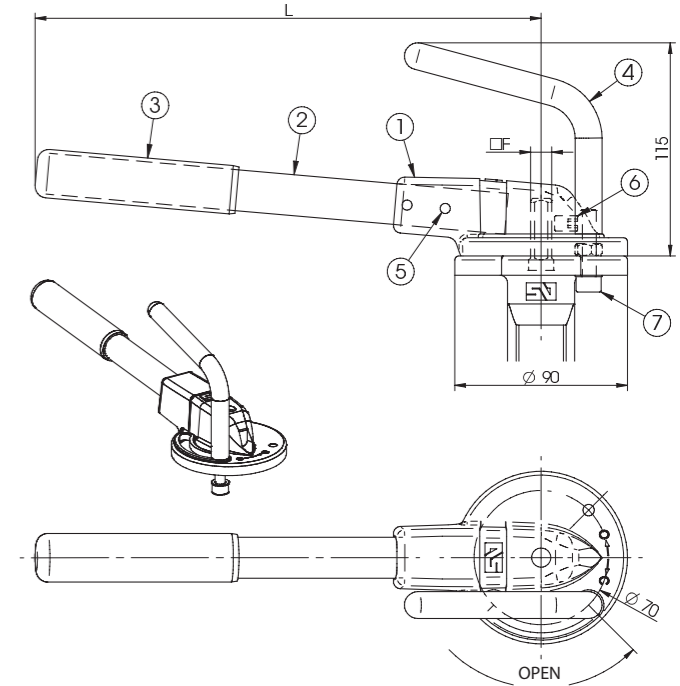
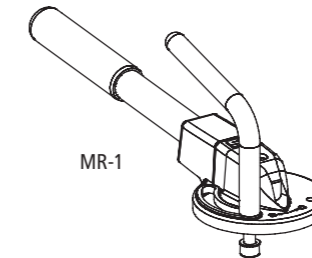

"MR-2" TYPE HANDLEVER: DN 250 TO DN 350 MM

Material

No.	Description	Material	Parts
1	Lever head	Aluminium + epoxy	1
2	Lever arm	Steel pipe + epoxy	1
3	Coverage	Vinyl	1
4	Blocking lever	Stainless steel AISI 420	1
5	Cap	Polyethylene	1
6	ALLEN tie DIN 916	Galvanised steel	1
7	ALLEN tie DIN 931 + nut DIN 934	Galvanised steel	1
8	Flange	Aluminium + epoxy	1
9	Screw C/ ALLEN DIN 912 + nut DIN 934	Galvanised steel	4

Weight of the lever MR-2 = 1.7 kg / part.

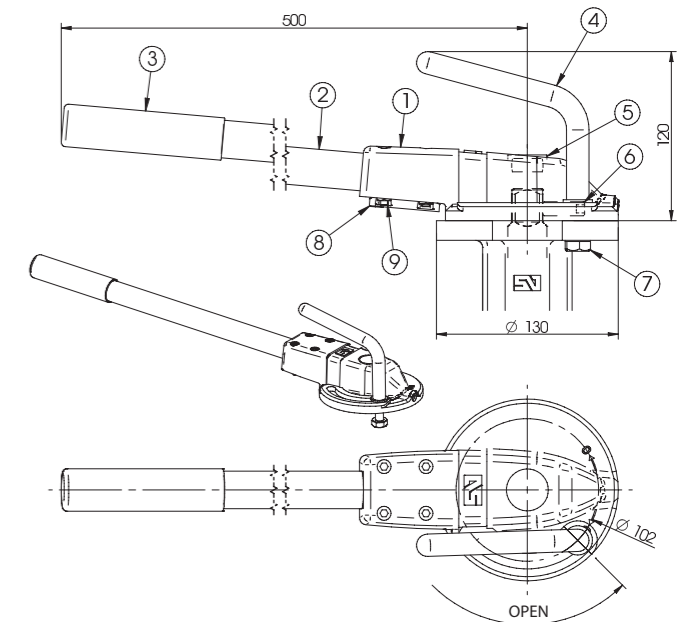
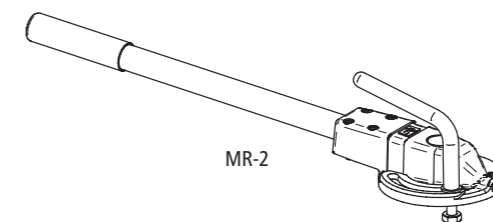

Manual gearbox with handwheel actuators

APPLICATIONS

- The range of quarter turn gearbox for the BV (DN 40 to DN 1200) is made of two series X and Q.
The name MDV of the gear units groups the set of the two series.
- The X serie gearbox for diameters DN 40 to DN 350.
Light to handle with an aluminium housing coated with powder epoxy Standard IP67 protection and IP68 possible on request.
Operating torques up to 600 Nm.

- The Q series gearbox for diameters DN 400 to DN 1200.
Housing in ductile iron coated powder epoxy and final coat in polyurethane. IP68 protection. Operating torques up to 7000 Nm
- The quarter turn travel starts from 0° at 90° adjustable with range of ± 5°.
Operating temperature -25°C and +110°C (-13°F to 230°F)



RANGE AND SELECTION

Selection of gear unit based on diameter of the concentric BV and the PFA

Type Gear unit	DN	Model for PFA10 bar	Model for PFA16 bar	Shaft connection valve	Handwheel Ø and H
X	40-100	MDV-0 / Type X-21		□ 11	Ø 125 and 42
	125-150	MDV-1 / Type X-21		□ 14	Ø 160 and 48
	200	MDV-1A / Type X-41		□ 17	Ø 200 and 53
	250-350	MDV-2 / Type X-61		□ 22	Ø 250 and 66
Q	400	MDV-2A / Type Q-800		□ 27	Ø 300 and 86
	450-500	MDV-3 / Type Q-2000		□ 36	Ø 400 and 122
	600	MDV-4 / Type Q-4000		Ø 60	Ø 500 and 141
	700	MDV-4 / Type Q-4000	MDV-5 / Type Q-6500	Ø 65	Ø 600 and 157
	750	MDV-6 / Type Q-12000		Ø 80	Ø 600 and 157
	800	MDV-5 / Type Q-6500		Ø 80	Ø 600 and 157
			MDV-6 / Type Q-12000	Ø 80	Ø 700 and 180
	900	MDV-6 / Type Q-12000		Ø 80	Ø 700 and 180
	1000	MDV-7 / Type Q-16000		Ø 80	Ø 700 and 180
	1100	MDV-7 / Type Q-16000	MDV-8 / Type Q-24000	Ø 80	Ø 700 and 180
1200	MDV-8 / Type Q-24000		Ø 100	Ø 700 and 180	

Dimensions in mm, weight in kg.

Technical characteristics

Type Gear unit	Reduction gear	Max. output torque (Nm)	Max. input torque (Nm)	Ratio	Number of closing turns	Weight (kg)	Mechanical advantage (%)
X	MDV-0	200	16.8	40:1	10	1.2	11.9
	MDV-1	200	16.8	40:1	10	1.4	11.9
	MDV-1A	400	31.2	44:1	11	2.6	12.8
	MDV-2	600	46.5	34:1	8.5	3.5	12.9
Q	MDV-2A	800	60	40:1	10	8.9	13.3
	MDV-3	2000	131	48:1	12	18.4	15.3
	MDV-4	4000	185	72:1	18	34.2	21.6
	MDV-5	6500	95	267:1	67	41.0	68.4
	MDV-6	12000	168.5	267:1	67	60.6	71.0
	MDV-7	16000	120	648:1	162	66.4	133.3
	MDV-8	24000	140	720:1	180	196.0	171.5

Dimensions in mm, weight in kg.

IP PROTECTION

- DN 40-350: Aluminium frame with IP67
- DN 400-1200: Cast iron frame with IP68 protection

Contact us for other materials or protections.



MDV-0 TO MDV-2 TYPE GEARBOX (SERIES X) FOR BV DN 40 TO DN 200

Dimensions (mm)

Ref.	A	B	C	D	E	F	H	J	K
MDV-0	84	118	43.5	50.5	128	51.2	125	F-07	11
MDV-1	84	118	43.5	50.5	135	51.2	160	F-07	14
MDV-1A	112	138.5	52.5	57.0	152	63.5	200	F-07/F-10	17
MDV-2	120	170.5	61.2	70.5	222	77.0	250	F-10/F-12	22

Material

Item	Description	Material	Parts
1	Body	Aluminium	1
2	Lid	Aluminium	1
3	Position indicator	Polyethylene	1
4	Quarter of toothed disk	Cast Iron GGG-40 – ASTM A356	1
5	Worm	Carbon steel C45/AISI 1045	1
6	Axle	Stainless steel AISI 303	1
7	Axial needle bearing	AXK-AS	2
8	Sealing joint	Nitrile/Silicon	1
9	Joint	Nitrile	2
10	Lubricant	Lithium/Calcium	1
11	Bearing	Permaglide P-10	2
12	Inserts	Steel	1
13	Screw	Steel 45H : DIN 915	2

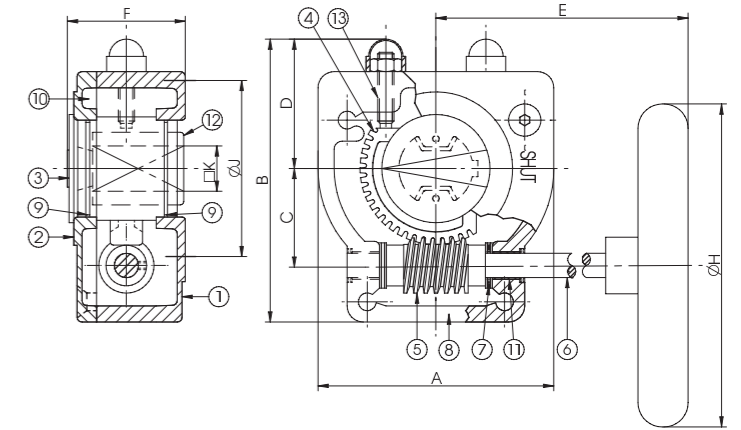

MDV-2A TO MDV-4 TYPE GEARBOX (SERIES X) FOR BV DN 250 TO DN 350

Dimensions (mm)

Ref.	A	B	C	D	E	F	H	J
MDV-2A	135	187	69	72.5	278	90.5	300	F-10/F-14
MDV-3	180	235	96.5	91.5	321	100	400	F-12/F-16
MDV-4	282	326	137.5	140	408	128	500	F-16/F-25
MDV-2	120	170.5	61.2	70.5	222	77.0	250	F-10/F-12

Material

Item	Description	Material	Parts
1	Body	Cast iron GG-25 – ASTM A48	1
2	Lid	Cast iron GG-25 – ASTM A48	1
3	Position indicator	Cast iron GG-25 – ASTM A48	1
4	Quarter of toothed disk	Cast Iron GGG-40 – ASTM A356	1
5	Worm	Carbon steel C45/AISI 1045	1
6	Axle	Stainless steel AISI 303	1
7	Axial needle bearing	AXK-AS	2
8	Sealing joint	Nitrile/Silicon	1
9	Joint	Nitrile	2
10	Lubricant	Lithium/Calcium	1
11	Bearing	Steel	2
12	Screw	Steel 45H : DIN 915	2

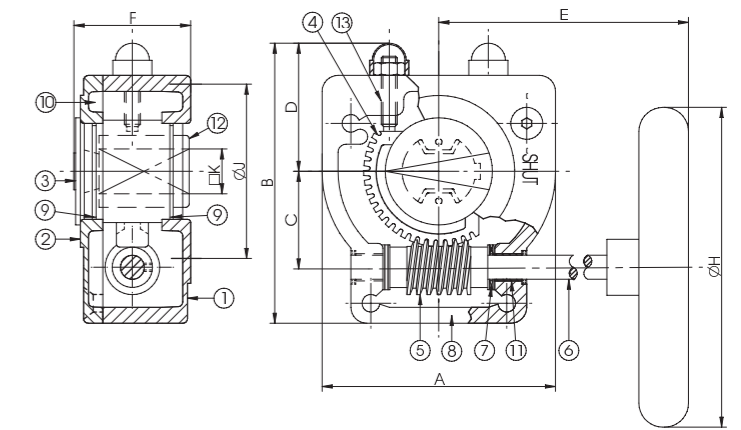

MDV-5 TO MDV-9 TYPE GEARBOX (SERIE Q) FOR RAP DN 400 TO DN 1200

Dimensions (mm)

Ref.	A	B	C	D	E	F	H	J
MDV-5	282	326	137.5	140	456	128	600	F-16/F-25
MDV-6	376	396	180.0	156	510	135	700	F-25/F-30
MDV-7	376	396	180.0	156	579	135	700	F-25/F-30
MDV-8	510	536	252.5	201	593	189	700	F-25/F-40

Material

Item	Description	Material	Parts
1	Body	Cast iron GG-25 – ASTM A48	1
2	Lid	Cast iron GG-25 – ASTM A48	1
3	Position indicator	Cast iron GG-25 – ASTM A48	1
4	Quarter of toothed disk	Cast iron GG-25 – ASTM A48	1
5	Worm	Carbon steel C45/AISI 1045	1
6	Axle	Stainless steel AISI 303	1
7	Axial needle bearing	AXK-AS	2
8	Sealing joint	Nitrile/Silicon	1
9	Joint	Nitrile	2
10	Lubricant	Lithium/Calcium	1
11	Bearing	Steel	2

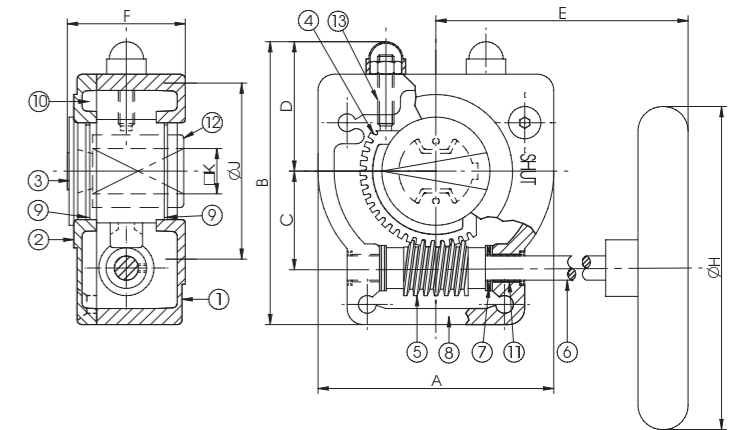

APPLICATIONS

- The standard range of PAM electric servomotors for the Wafer and Lug BV is Auma. Actuators produced by Bernard are used in special cases where this type of electric motorisation is recommended. For other manufacturers, please contact us.
- Small diameters with quarter turn type servomotors without gear unit. Large diameters with multi-turn + gear unit and gear reducer.

- Electric power supply can be given through three-phase or single-phase assembly.
- These applications include energy (hydro-electric plants), chemical industry and in the water treatment plants among others, etc.

RANGE AND SELECTION

The servomotor is selected based on the DN and the PFA of the BV. It is not dependent on the type of BV.

Auma

DN 40 – 400 mm with SG AUMA NORM quarter turn servomotor without servomotor control.

DN 450 – 1200 mm with SA multi-turn servomotor + GS type gearbox and VZ/GZ primary reduction gearing.

DN	Auma servomotor/gearbox		
	PFA10 bar	PFA16 bar	PFA25 bar
40	11/2"	SG03.3	SG04.3
50	2"	SG03.3	SG04.3
60/65	2 1/2"	SG03.3	SG04.3
80	3"	SG04.3	SG05.1
100	4"	SG04.3	SG05.1
125	5"	SG05.1	SG07.1
150	6"	SG05.1	SG07.1
200	8"	SG07.1	SG07.1
250	10"	SG10.1	SG10.1
300	12"	SG10.1	SG10.1
350	14"	SG10.1	SG12.1
400	16"	SG12.1	SG12.1
450	18"	GS100.3/VZ4.3/SA07.2	GS100.3/VZ4.3/SA07.6
500	20"	GS100.3/VZ4.3/SA07.2	GS100.3/VZ4.3/SA07.6
600	24"	GS100.3/VZ4.3/SA07.6	GS100.3/VZ4.3/SA07.6
700	28"	GS125.3/VZ4.3/SA10.2	GS125.3/VZ4.3/SA10.2
750	30"	GS125.3/VZ4.3/SA10.2	GS125.3/VZ4.3/SA10.2
800	32"	GS125.3/VZ4.3/SA10.2	GS160.3/GZ160.3(8:1)/SA10.2
900	36"	GS160.3/GZ160.3(8:1)/SA07.6	GS160.3/GZ160.3(8:1)/SA10.2
1000	40"	GS160.3/GZ160.3(8:1)/SA10.2	GS200.3/GZ200.3(8:1)/SA10.2
1100	44"	GS160.3/GZ160.3(8:1)/SA10.2	GS200.3/GZ200.3(16:1)/SA10.2
1200	48"	GS200.3/GZ200.3(8:1)/SA10.2	GS200.3/GZ200.3(16:1)/SA10.2

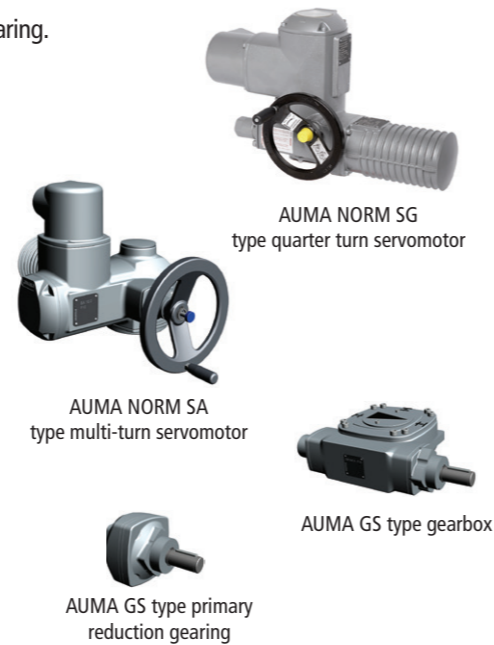

Bernard

OA type small diameters, ASP/AS type medium diameters all quarter turn.

From DN 900 (PFA16 bar) and DN 1000 (PFA10 bar) onwards: ASM / ST multi-turn servomotors with SBW primary reduction gearing.

DN	Bernard servomotor/gearbox		
	PFA10 bar	PFA 16 bar	PFA25 bar
40	11/2"	OA-6	OA-6
50	2"	OA-6	OA-6
60/65	2 1/2"	OA-6	OA-6
80	3"	OA-6	OA-8
100	4"	OA-6	OA-8
125	5"	OA-8	OA-15
150	6"	OA-15	ASP
200	8"	OA15	ASP
250	10"	ASP	AS-50
300	12"	AS-50	AS-80
350	14"	AS-80	AS-100
400	16"	AS-100	AS-100
450	18"	AS-200	AS-200
500	20"	AS-200	AS-200
600	24"	AS-400	AS-400
700	28"	AS-600	AS-600
750	30"	AS-1000	AS-1000
800	32"	AS-1000	AS-1000
900	36"	AS-1000	ASM1+SBWG05-1-SDM
1000	40"	ASM1+SBWG05-1-SDM	ASM2+SBWG55-1-SDM
1100	44"	ASM2+SBWG55-1-SDM	ASM2+SBWG55-1-SDM
1200	48"	ASM2+SBWG55-1-SDM	ST70+SBWG55-1-SM



TECHNICAL CHARACTERISTICS

AUMA MOTORISATION FOR PFA 10 bar

DN	Type	Gear unit		Auma Norm quarter turn servomotor		
		No. of turns	Max. torque (Nm)	Type	Max. torque (Nm)	Time (s)
40	11/2"			SG03.3	32	22
50	2"			SG03.3	32	22
60	2 1/2"			SG03.3	32	22
65	2 1/2"			SG03.3	32	22
80	3"			SG04.3	63	22
100	4"			SG04.3	63	22
125	5"			SG05.1	150	22
150	6"			SG05.1	150	22
200	8"			SG07.1	300	22
250	10"			SG10.1	600	32
300	12"			SG10.1	600	32
350	14"			SG10.1	600	32
400	16"			SG12.1	1200	32
450	18"	GS100.3/VZ4.3	52	4000	SA07.2	30
500	20"	GS100.3/VZ4.3	52	4000	SA07.2	30
600	24"	GS100.3/VZ4.3	52	4000	SA07.6	60
700	28"	GS125.3/VZ4.3	52	8000	SA10.2	120
750	30"	GS125.3/VZ4.3	52	8000	SA10.2	120
800	32"	GS125.3/VZ4.3	52	8000	SA10.2	120
900	36"	GS160.3/GZ160.3(8:1)	110,5	14000	SA07.6	60
1000	40"	GS160.3/GZ160.3(8:1)	110,5	14000	SA10.2	120
1100	44"	GS160.3/GZ160.3(8:1)	110,5	14000	SA10.2	120
1200	48"	GS200.3/GZ200.3(8:1)	108,5	28000	SA10.2	120

(*) The servomotors have a wide range of speeds and open-close times. They can be adjusted to the customer requirements.

AUMA MOTORISATION FOR PFA 16 bar

DN	Type	Gear unit		Auma Norm quarter turn servomotor		
		No. of turns	Max. torque (Nm)	Type	Max. torque (Nm)	Time (s)
200	8"			SG07.1	300	22
250	10"			SG10.1	600	32
300	12"			SG10.1	600	32
350	14"			SG12.1	1200	32
400	16"			SG12.1	1200	32
450	18"	GS100.3/VZ4.3	52	4000	SA07.6	60
500	20"	GS100.3/VZ4.3	52	4000	SA07.6	60
600	24"	GS100.3/VZ4.3	52	4000	SA07.6	60
700	28"	GS125.3/VZ4.3	52	8000	SA10.2	120
750	30"	GS125.3/VZ4.3	52	8000	SA10.2	120
800	32"	GS160.3/GZ160.3(8:1)	110,5	14000	SA10.2	120
900	36"	GS160.3/GZ160.3(8:1)	110,5	14000	SA10.2	120
1000	40"	GS200.3/GZ200.3(8:1)	108,5	28000	SA10.2	120
1100	44"	GS200.3/GZ200.3(16:1)	216	28000	SA10.2	120
1200	48"	GS200.3/GZ200.3(16:1)	216	28000	SA10.2	120

(*) The servomotors have a wide range of speeds and open-close times. They can be adjusted to the customer requirements.

AUMA MOTORISATION FOR PFA 25 bar

DN	Auma Norm quarter turn servomotor		
	Type	Max. torque (Nm)	Time (s)
40	11/2"	SG04.3	63
50	2"	SG04.3	63
60	2 1/2"	SG04.3	63
65	2 1/2"	SG04.3	63
80	3"	SG05.1	150
100	4"	SG05.1	150
125	5"	SG07.1	300
150	6"	SG07.1	300
200	8"	SG10.1	600
250	10"	SG12.1	1200
300	12"	SG12.1	1200

The max. torque of the gearbox is the maximum resistance capacity, independent of the BV's torque.

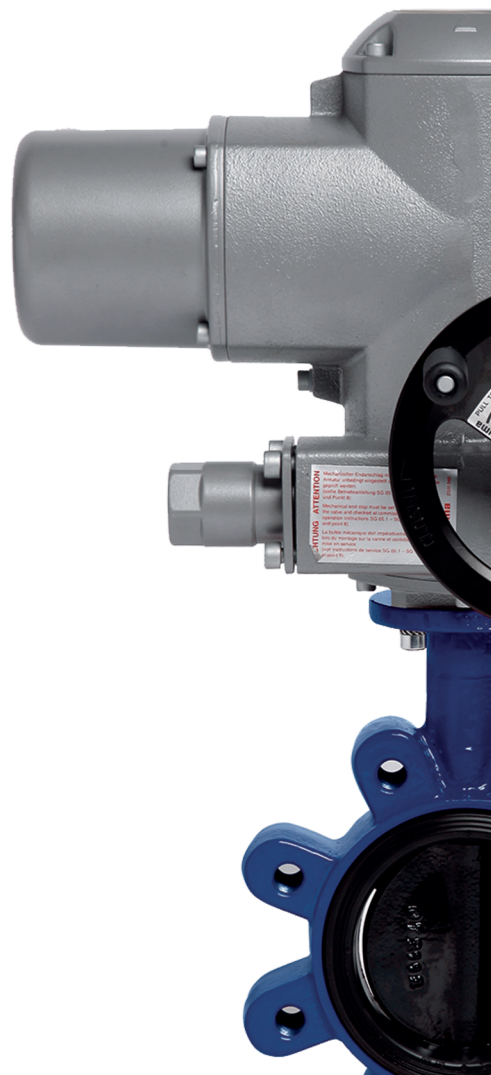
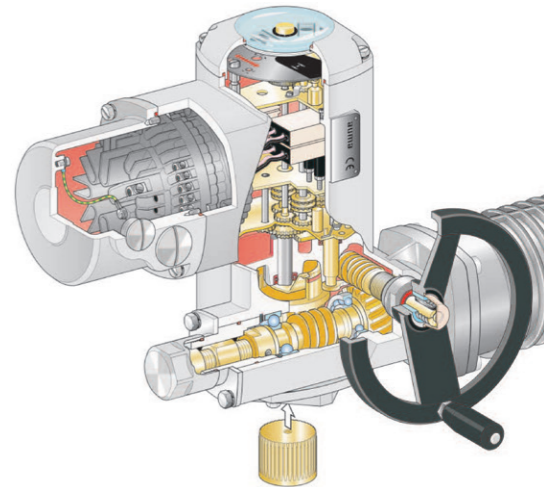

APPLICATIONS

- The fluid used for the pneumatic actuators is generally compressed air at a network pressure of 6 bar (max. 8 bar) and a temperature between -32°C and +90°C.
- There are two models: the "PA" type and the "P" type.
- The "PA" type operating mechanism is made of 2 to 6 pre-compressed springs with a unitary safety system per spring. Easy to mount and change.
- The "P" type operating mechanism is made of 2 concentric springs on each side without initial pre-compression. The safety system is optional.

- Two operating options: **spring return** and **double effect** with operating torques from 15 Nm to 5000 Nm.
- Spring return is made of a **single chamber with piston plus a mechanical spring**. In case of absence of air, the spring returns the piston to its initial position.
- The double effect is made of **two chambers**. In case of absence of air, the piston remains in its final position.

RANGE AND SELECTION

Selection of the "PA" or "P" type mechanism is done based on the DN of the BV, the network pressure and the type of actuator.

The difference between these two mechanisms is in the type of springs used:

- "PA" type: from 2 to 6 pre-compressed springs with expansion limiter (new version)
- "P" type: 1 or 2 concentric springs (old version)

DN	Double effect			Spring return		
	PFA6 bar	PFA10 bar	PFA16 bar	PFA6 bar	PFA10 bar	PFA16 bar
40	PA00	PA00	PA00	PA00S		
50				PA05S		
65	PA05	PA05	PA05	PA10S		
80				PA15S		
100	PA10	PA15	PA10	PA20S		
125				PA25S		
150	PA15	PA20	PA15	P30S		
200				P40S		
250	PA20	PA25	PA20	P50S (*)		
300				PA60S (*)		
350	PA25	P30	P30	PA70S (*)		
400				P40		
450	P40	P40	P40	P50 (*)		
500				PA60 (*)		
500 (DN600*)	P50	P50	(DN400*)	PA70 (*)		
600				PA60 (*)		
600 (DN500*)	PA60 (*)	PA70 (*)	PA60 (*)	PA70 (*)		
700				PA70 (*)		
800	PA70 (*)					

(*) Special mounting, please contact us.



"PA" type pneumatic servomotor



"P" type pneumatic servomotor

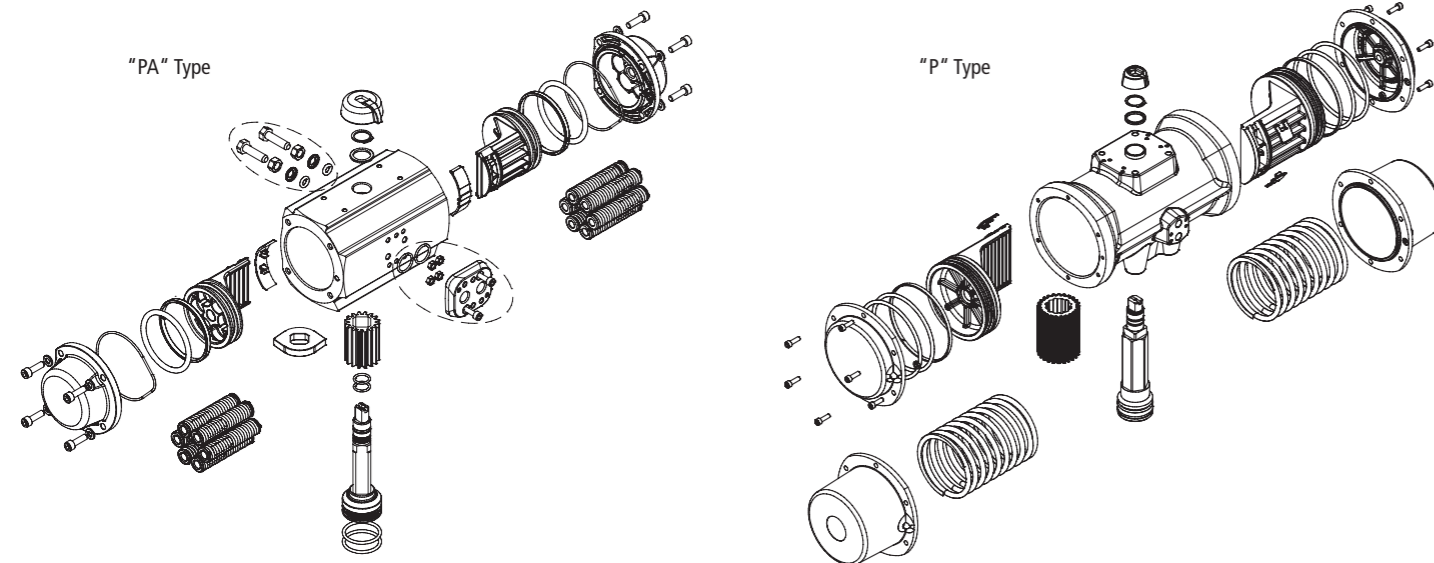

TECHNICAL CHARACTERISTICS

HANDLING TORQUES

DE - Double effect		SE - Spring return					
Type	Air 6 bar (Nm)	Type	No. of springs	Springs (Nm)		Air 6 bar (Nm)	
				Initial	Final	Initial	Final
PA00	25	PA00S	6	16.5	11.1	13.9	8.5
PA05	49.7	PA05S	6	31.4	20.9	28.8	18.3
PA10	71	PA10S	6	45.6	30.8	40.2	25.4
PA15	116.5	PA15S	6	71.5	49	67.5	45
PA20	165.5	PA20S	6	104.7	65.8	99.7	60.8
PA25	290	PA25S	6	181.8	119.4	170.6	108.2
P30	469.2	P30S	4	273.7	179.9	289.3	195.5
P40	1180	P40S	4	766.9	491.6	688.3	413
P50	2067	P50S	4	1206	723.6	1344	861.4
PA60	3458	PA60S	6	2075	1383	2075	1383
PA70	5043	PA70S	6	3539	1769	3273	1504

HANDLING TIME

Handling time in seconds					
DE	SE	Weight in kg		Double effect	
		SE	SE	Open	Close
PA00	PA00S	1.40	1.62	0.15	0.15
PA05	PA05S	2.57	2.94	0.2	0.2
PA10	PA10S	3.08	3.48	0.25	0.25
PA15	PA15S	4.20	5.04	0.3	0.3
PA20	PA20S	5.61	6.63	0.4	0.4
PA25	PA25S	9.30	11.3	0.5	0.5
P30	P30S	9.10	15.9	0.6	0.6
P40	P40S	17.6	36.4	1.2	1.2
P50	P50S	30.7	58.4	2	2
PA60	PA60S	48.3	83.2	3	3
PA70	PA70S	77.9	118.2	4	4

Handling time in seconds					
DE	SE	Weight in kg		Spring return	
		SE	SE	Open	Close
PA00	PA00S	1.40	1.62	0.2	0.2
PA05	PA05S	2.57	2.94	0.25	0.25
PA10	PA10S	3.08	3.48	0.3	0.3
PA15	PA15S	4.20	5.04	0.4	0.4
PA20	PA20S	5.61	6.63	0.5	0.5
PA25	PA25S	9.30	11.3	0.8	0.8
P30	P30S	9.10	15.9	1.2	1.2
P40	P40S	17.6	36.4	2	2
P50	P50S	30.7	58.4	6	6
PA60	PA60S	48.3	83.2	6	5
PA70	PA70S	77.9	118.2	8	6

REQUIREMENT OF VOLUME OF LITRES AT ATMOSPHERIC PRESSURE

SE - Spring return		DE - Double effect	
Type	Open	Open	Close
PA00S	0.15	0.15	0.18
PA05S	0.28	0.28	0.37
PA10S	0.35	0.35	0.45
PA15S	0.65	0.65	0.82
PA20S	0.8	0.8	1.15
PA25S	1.5	1.5	2.02
P30S	2.05	P30	1.9
P40S	5.3	P40	5.3
P50S	10.5	P50	7
PA60S	19.5	PA60	20.7
PA70S	31	PA70	30



■ The short gap concentric Butterfly Valves are ready to be installed between two flat flanges. Sealing between the BV and the network is done with the BV sleeve. **The flat sealing joints must not under any circumstances be used between the flanges of the network and the sleeve of the BV.**

■ Calculation of the length of fastenings will depend on several factors: diameter and type of the BV, PFA/PN pressure and material of the network (ductile iron, steel, plastic, etc.), type of flat flanges (fixed, movable, etc.), type of fastenings (ties, bolts, etc.), use of structural elements (support plates, etc.).
 ■ Specific calculations of the length of fastening is recommended.

WAFER BV

Connection to the network can be made with:

- 1 Screw + nut + two washers
- 2 Tie + two nuts + two washers
- 3 For the DN 450 (PN10 and 16) and DN 700 up to 1200 (PN10, 16 and 20), there are 8 screws with washers to tighten on both sides.

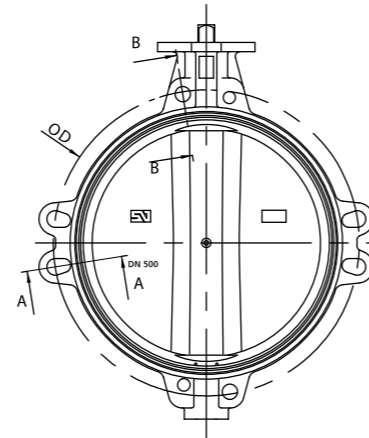
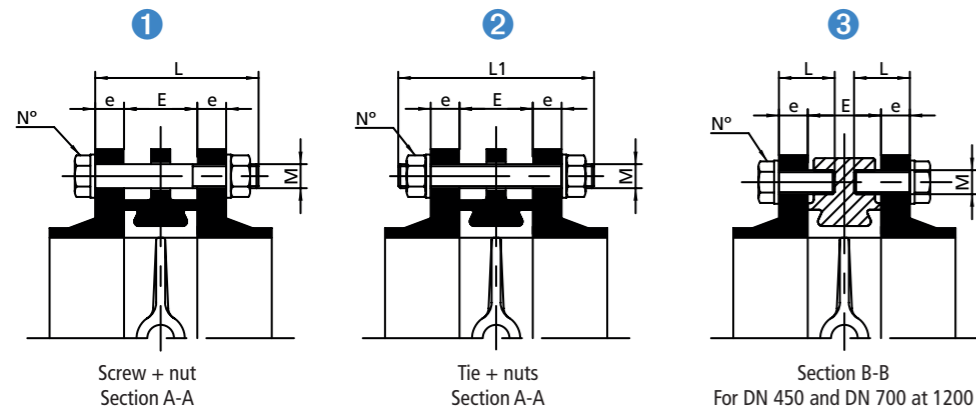

DN	E	PN10						PN16bar					PN25						
		D	e	M	L	L1	N°	D	e	M	L	L1	N°	D	e	M	L	L1	N°
40	33	110	16	M16	90	110	4	110	16	M16	90	110	4	110	18	M16	90	110	4
50	43	125	18	M16	100	120	4	125	18	M16	100	120	4	125	20	M16	105	125	4
65	46	145	18	M16	100	120	4	145	18	M16	100	120	4	145	22	M16	110	130	8
80	46	160	20	M16	110	130	8	160	20	M16	110	130	8	160	24	M16	115	135	8
100	52	180	20	M16	110	130	8	180	20	M16	110	130	8	190	24	M20	125	150	8
125	56	210	22	M16	120	140	8	210	22	M16	120	140	8	220	26	M24	137	166	8
150	56	240	22	M20	130	150	8	240	22	M20	130	150	8	250	28	M24	142	172	8
200	60	295	24	M20	130	160	8	295	24	M20	130	160	12	310	30	M24	150	180	12
250	68	350	26	M20	150	170	12	355	26	M24	150	170	12	370	32	M27	165	197	12
300	78	400	26	M20	160	180	12	410	28	M24	160	180	12	430	34	M27	178	210	16
350	78	460	26	M20	170	180	16	470	30	M24	170	190	16						
400	102	515	26	M24	180	210	16	525	32	M27	200	220	16						
450	114	565	26	M24	190	220	16			M27	210	240	16						
				M24	60		8	585	32	M27	60		8						
500	127	620	28	M24	210	230	20	650	34	M30	230	260	20						
600	154	725	28	M27	240	270	20	770	36	M33	260	290	20						
700	165	840	30	M27	260	280	20	840	36	M33	270	300	20						
				M27	80		8			M33	85		8						
750	190	900	32	M30	290	320	20	900	38	M33	300	340	20						
				M30	95		8			M33	100		8						
800	190	950	32	M30	290	320	20	950	38	M36	310	345	20						
				M30	110		8			M36	80		8						
900	203	1050	34	M30	310	350	24	1050	40	M36	330	375	24						
				M30	100		8			M36	100		8						
1000	216	1160	34	M33	325	360	24	1170	42	M39	345	390	24						
				M33	95		8			M39	100		8						
1100	216	1270	38	M33	330	370	28	1270	48	M39	360	400	28						
				M33	100		8			M39	110		8						
1200	254	1380	38	M36	375	420	28	1390	48	M45	395	445	28						
				M36	110		8			M45	115		8						

Dimensions in mm and units.

LUG BV

Connection to the network can be made only with screw + washer on each side.

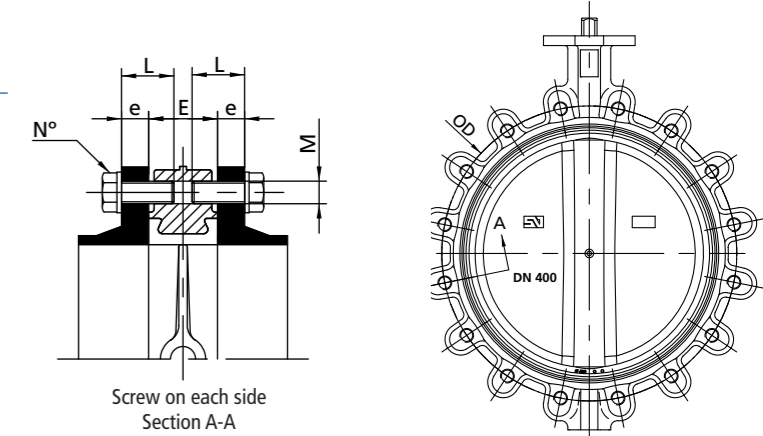

DN	E	PFA10 bar						PFA16 bar					PFA25 bar				
		D	e	M	L	No.	D	e	M	L	No.	D	e	M	L	N°	
40	33	110	16	M16	30	8	110	16	M16	30	8	110	18	M16	30	8	
50	43	125	18	M16	35	8	125	18	M16	35	8	125	20	M16	40	8	
65	46	145	18	M16	40	8	145	18	M16	40	8	145	22	M16	45	16	
80	46	160	20	M16	40	16	160	20	M16	40	16	160	24	M16	45	16	
100	52	180	20	M16	45	16	180	20	M16	45	16	190	24	M20	50	16	
125	56	210	22	M16	50	16	210	22	M16	50	16	220	26	M24	50	16	
150	56	240	22	M20	50	16	240	22	M20	50	16	250	28	M24	55	16	
200	60	295	24	M20	50	16	295	24	M20	50	24	310	30	M24	60	24	
250	68	350	26	M20	60	24	355	26	M24	60	24	370	32	M27	65	24	
300	78	400	26	M20	65	24	410	28	M24	65	24	430	34	M27	70	32	
350	78	460	26	M20	65	32	470	30	M24	65	32						
400	102	515	26	M24	75	32	525	32	M27	80	32						
450	114	565	26	M24	75	32	585	32	M27	80	32						
				M24	60	8			M27	60	8						
500	127	620	28	M24	90	40	650	34	M30	95	40						
600	154	725	28	M27	100	40	770	36	M33	110	40						
700	165	840	30	M27	110	40	840	36	M33	120	40						
				M27	80	8			M33	85	8						
750	190	900	32	M30	130	40	900	38	M33	130	40						
				M30	95	8			M33	100	8						
800	190	950	32	M30	130	40	950	38	M36	130	40						
				M30	110	8			M36	80	8						
900	203	1050	34	M30	130	48	1050	40	M36	140	48						
				M30	100	8			M36	100	8						
1000	216	1160	34	M33	140	48	1170	42	M39	150	48						
				M33	95	8			M39	100	8						

Dimensions in mm and units.

"PF" TYPE DISMANTLING JOINT

DN	Reference	PFA10 bar TIES				Weight (kg)	PFA16 bar TIES				Weight (kg)
		N	M	L	N		M	L			
50	160943	4	M16	250	10	160943	4	M16	250	10	
65	163543	4	M16	250	16	163543	4	M16	250	16	
80	160947	8	M16	250	21	160947	8	M16	250	21	
100	163559	8	M16	250	20	163559	8	M16	250	20	
125	166645	8	M16	250	34	166645	8	M16	250	34	
150	163605	8	M20	290	34	163605	8	M20	290	34	
200	163634	8	M20	290	48	160966	12	M20	290	64	
250	163658	12	M20	290	74	163359	12	M24	320	102	
300	173460	12	M20	290	100	160969	12	M24	320	116	
350	166654	16	M20	290	124	173472	16	M24	350	162	
400	163707	16	M24	320	160	171567	16	M27	350	204	
450	-	20	M24	320	176	-	20	M27	350	232	
500	160970	20	M24	340	202	163731	20	M30	380	312	
600	160971	20	M27	340	268	163742	20	M33	400	416	
700	163750	24	M27	340	330	173475	24	M33	400	444	
800	163762	24	M30	380	454	160942	24	M36	450	610	
900	163770	28	M30	380	522	173476	28	M36	450	692	
1000	160950	28	M33	420	632	160951	28	M39	450	890	
1200	163586	32	M36	450	1200	173477	32	M45	525	1392	

Dimensions in mm and units.

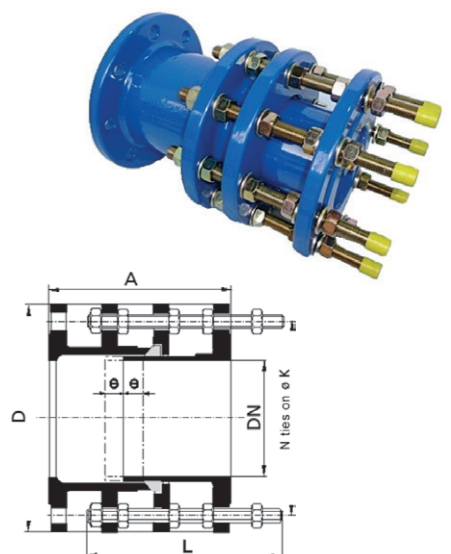

The Saint-Gobain PAM butterfly valves have been designed in accordance with the following specifications:

- Mounting between flat or welding neck flanges to DIN or ANSI standards.
- Flange gasket are not required. When fitted between the counter flanges the lips on the elastomer liner ensure watertight shut-off between the valve body and flanges.
- **No support required.** When clamped between flanges and corresponding piping no further support is necessary, neither for the valve, nor for its controls.

DIMENSIONS OF FLANGES AND ADAPTERS

Flanges and adapters must ensure proper mechanical joint with the valve thereby allowing:

- Perfect water tightness,
- Normal operation of the valve and especially free movement of the disk,
- That the internal diameter of the flanges are suitable for the proper operation of the valve.

In the case of a too small diameter of the flanges (see Fig. 3), it may become impossible to operate the disk and it may get damaged.

A too large diameter of the flanges (see Fig. 2) can cause a lack of seal in the sealing area.

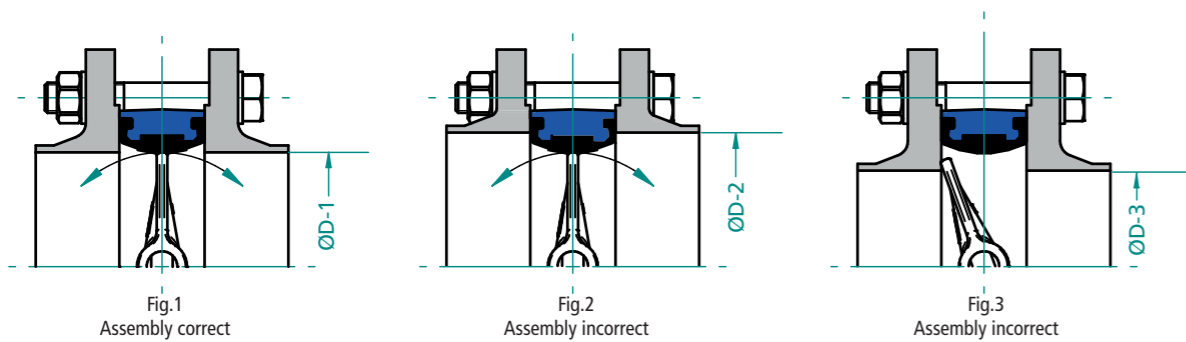

DN	Inches	øD-1 Optimal (mm)	øD-2 Max. (mm)	øD-3 Min. (mm)	øD-4 Max. (mm)
40	1 1/2"	40	50	30	26
50	2"	50	61	40	30
65	1 1/2"	65	75	55	47
80	3"	80	90	70	66
100	4"	105	115	95	90
125	5"	125	140	120	113
150	6"	150	170	145	139
200	8"	200	220	200	193
250	10"	250	270	245	241
300	12"	300	325	295	290
350	14"	350	370	345	338
400	16"	400	420	395	387
450	18"	450	475	442	437
500	20"	500	525	490	478
600	24"	600	624	587	578
700	28"	700	715	693	678
800	32"	800	818	795	767
900	36"	900	922	880	867
1000	40"	1000	1023	980	964
1100	44"	1100	1123	1086	1054
1200	48"	1200	1225	1190	1158

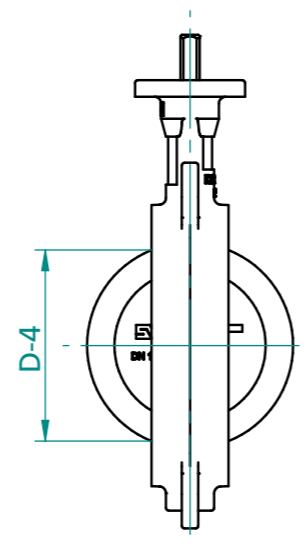

RECOMMENDATIONS

- Weld the pipe and the flanges far from the BV to avoid damaging the coating and the elastomer sleeve with the heat (fig. 4).
- Not welding residue should appear on the flat faces of the flanges in contact with the valve.
- The flanges should be flat, so check that the welding has not deformed them.
- Avoid sharp edges that may damage the elastomer sleeve during assembly, by getting perfect parallelism and alignment of the flanges.
- A parallelism error may result in loss of sealing of the BV, since the sleeve will not be compressed in the correct manner along its perimeter. (Fig. 5).

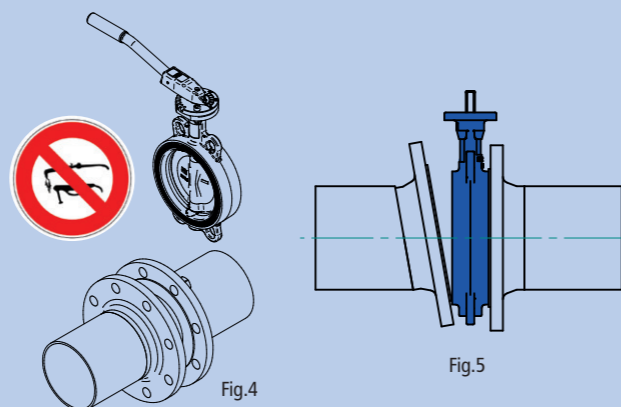

ASSEMBLY INSTRUCTIONS BETWEEN FLANGES

1. **Move the two flanges with enough distance from the network** so that the valve slides smoothly without damaging the lips of the elastic ring.

The butterfly will be in half-open position with no projection outside the valve width. (see fig. 1).

2. **Centre the valve** with the four screws/ties (two upper and two lower) without tightening them.

Test the opening and closing of the butterfly to ensure its operation. **Place the butterfly in perfectly centred position and open** taking care not to damage its periphery (see fig. 2).

Tighten the screws/ties to fix the position of the BV.

3. **Tighten the nuts** until there is metal-metal contact between the body of the BV and the flanges of the network.

Tighten the screws/ties "diagonally" and progressively.

The tightening torque must be adequate to make metal-metal contact and less than the resistance capacity of the screw/tie (see fig. 3).

Tightening torque for screws/ties:

- . M16: 90 Nm
- . M20: 180 Nm

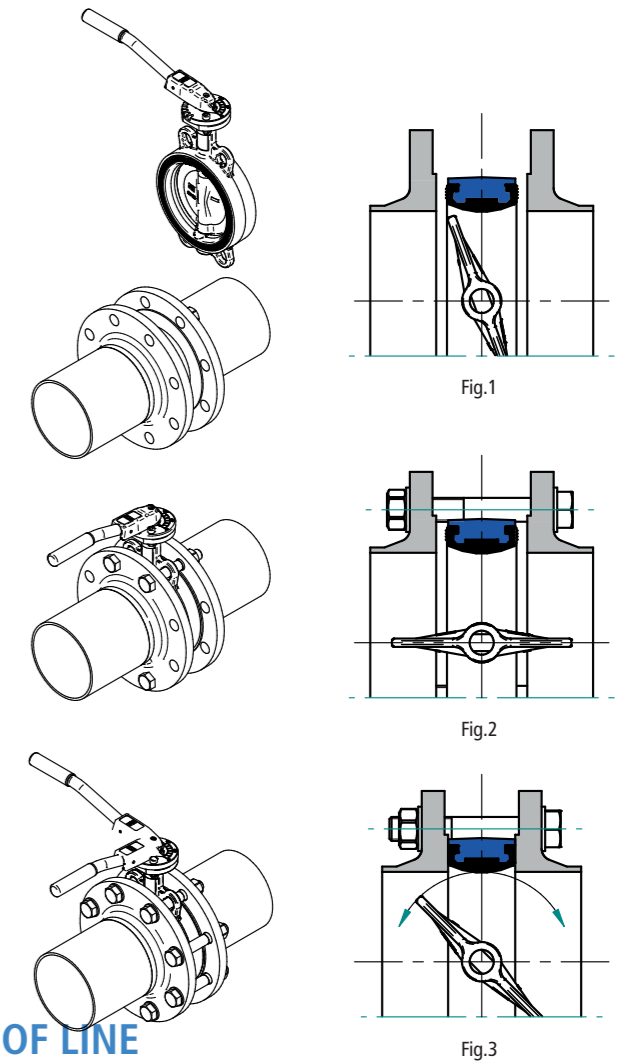

LUG TYPE ASSEMBLY INSTRUCTIONS AT END OF LINE

This type of BV is most suited for dismantling the pipe at the end of line. Water piping in the downstream can be dismantled by maintaining pressure in the remaining upstream network.

For dismantling the downstream circuit of the BV, it is important to note the following instructions:

1) **Close the valve** to avoid over-pressure or a water hammer. In addition to closing the valve, need to isolate the circuit, stop the pumps and clean the pipes of fluid.

2) **Ensure that the network pressure (upstream) does not exceed the limits indicated below:**

- . For DN 40-150 mm (PN 16 x 0.4)= 6.4 bar
- . For DN 200-1200 mm (PN 10 x 0.4)= 4.0 bar

The diagram alongside shows the steps to be followed during INITIAL ASSEMBLY (see fig. 1), the next phase requires loosening all the nuts of the "DOWNSTREAM WATER" and dismantling the flange (see fig. 2).

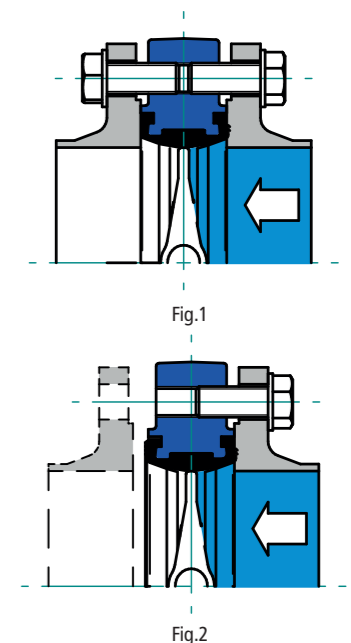

SAINT-GOBAIN PAM worldwide

ALGERIA

SAINT-GOBAIN PAM ALGERIE
Z.I. Sidi Abdelkader-Ben Boulaid - BP 538
09000 - BLIDA - Algeria
Phone: + 213 (0) 25 36 00 60

ARGENTINA

SAINT-GOBAIN PAM ARGENTINA
Bouchard y Enz
1836 - LLAVALLOL - BUENOS AIRES - Argentina
Phone: + 54 11 42 98 9600

AUSTRALIA

SAINT-GOBAIN PAM
15 Edgars Road
THOMASTOWN VIC 3074 - Australia
Phone: + 61 (0) 3 9358 6122

AUSTRIA

**SAINT-GOBAIN GUSSROHRVERTRIEB
ÖSTERREICH GmbH**
Archenweg, 52
A-6020 - INNSBRUCK - Austria
Phone: + 43 512 341 717-0

BELGIUM

SAINT-GOBAIN PIPE SYSTEMS
Raatshovenstraat, n°2
B-3400 - LANDEN - Belgium
Phone: + 32 11 88 01 20

BRAZIL

SAINT-GOBAIN CANALIZACAO LTDA
Praia de Botafogo 440 7º andar
22250-040 - RIO DE JANEIRO - RJ - Brazil
Phone: + 55 21 2128 1677

CHILE

SAINT-GOBAIN PAM CHILE
Antillanca Norte 600
Parque Industrial Vespucio, Comuna de Pudahuel
SANTIAGO DE CHILE - Chile
Phone: + 562 444 13 00

CHINA

SAINT-GOBAIN PAM CHINA (SHANGAI)
7th Floor, Office Tower
Bund Center - 222 Yan'an Road (East)
200002 - SHANGAI - China
Phone: + 86 21 6361 2142

SAINT-GOBAIN PAM CHINA (XUZHOU)

Dong Jiao Yangzhuang
PC 221004 - XUZHOU - Jiangsu Province - China
Phone: + 86 516 8787 8107

SAINT-GOBAIN PAM CHINA (MAANSHAN)

Hua Gong Road Cihu
PC 243052 - MAANSHAN Anhui Province - China
Phone: + 86 555 350 8040

COLOMBIA

SAINT-GOBAIN PAM COLOMBIA
Terminal terrestre de carga de Bogota
Etapa 1, Bodega 9, Modulo 3
Km 3,5 costado sur autopista - Medellin
COTA CUNDINAMARCA - Colombia
Phone: + 57 (1) 841 5832

CZECH REPUBLIC

SAINT-GOBAIN PAM CZ s.r.o.
Počernická 272/96
108 03 Praha 10 - Czech Republic
Phone: + 296 411 746

FINLAND

SAINT-GOBAIN PIPE SYSTEMS OY
Nuijamiestentie 3A
FIN-00400 - HELSINKI - Finland
Phone: + 358 207 424 600

FRANCE & DOM-TOM

SAINT-GOBAIN PAM (HEAD OFFICE)
21, avenue Camille Cavallier
54705 PONT-A-MOUSSON CEDEX - France
Phone: +33 3 83 80 73 50

SAINT-GOBAIN PAM

(France Commercial Department)
CRD - Chemin de Blénod - B.P. 109
54704 PONT A MOUSSON CEDEX - France
Phone: +33 3 83 80 73 00

SAINT-GOBAIN PAM

(Europe and International Commercial Departments)
21 avenue Camille Cavallier
54705 - PONT A MOUSSON CEDEX - France
Phone: + 33 3 83 80 67 89

SAINT-GOBAIN PAM

(Local Agency of The Antilles)
Rue Alfred Lumière - ZI de Jarry - BP 2104
97122 - BAIE MAHAULT - Guadeloupe
Phone: + 33 590 26 71 46

GERMANY

SAINT-GOBAIN PAM DEUTSCHLAND
Saarbrucker Strasse 51
66130 - SAARBRUCKEN - Germany
Phone: + 49 681 87 010

GREECE

SAINT-GOBAIN SOLINOURGEIA
5 Klissouras Str.
GR 14482 - METAMORFOSI - ATHENS - Greece
Phone: + 30 210 28 31 804

HONG KONG

SAINT-GOBAIN PIPELINES
H15/F Hermes Commercial Centre - 4-4A Hillwood Road
TSIM SHA TSUI - KOWLOON - Hong Kong
Phone: + 852 27 35 78 26

INDIA

SAINT-GOBAIN PAM
Grindwell Norton Ltd
5th Level, Leela Business Park - Andheri-Kurla Road
MUMBAI - 400059 - India
Phone: + 91 22 402 12 121

ITALY

SAINT-GOBAIN PAM ITALIA SPA
Via Romagnoli n°6
I-20146 - MILAN - Italy
Phone: + 39 02 42 431

JORDAN

SAINT-GOBAIN PAM REGIONAL OFFICE
Abu Zaid Center - Office # 8
35 Saad Bin Abi Waqqas St. - PO BOX 831000
11183 AMMAN - Jordan
Phone: + 962 6 551 4438

MOROCCO

SAINT-GOBAIN MAROC DEVELOPMENT
2 allée des Figuiers - Ain Sebaâ
CASABLANCA - Morocco
Phone: + 212 522 66 57 31

MEXICO

SAINT-GOBAIN PAM MEXICO
HORACIO 1855-502 - Colonia Los Morales - Polanco
11510 - MEXICO D.F. - Mexico
Phone: + 52 55 5279 1657

NETHERLANDS

SAINT-GOBAIN PIPE SYSTEMS
Markerkant 10-17
1316 - AB ALMERE - Nederland
Phone: + 31 36 53 333 44

NORWAY

SAINT-GOBAIN PAM NORWAY
Brobekkeveien 84
N-0614 OSLO - Norway
Phone: + 47 23 17 58 60

PERU

SAINT-GOBAIN PAM PERU
Avenida de los Faisanes N° 157 - Chorillos
LIMA 09 - Peru
Phone: + 51 1 252 40 34/35

POLAND

**SAINT-GOBAIN CONSTRUCTION PRODUCTS POLSKA
SP Z.O.O. - PAM Business Unit**
Ul. Cybertyki 21
PL-02-677 WARSZAWA - Poland
Phone: + 48 22 751 41 72

PORTUGAL

SAINT-GOBAIN PAM PORTUGAL
Est. Nac. 10 - Lugar de D. Pedro -Apartado 1708
P-2690-901 - SANTA IRIA DE AZOIA - Portugal
Phone: + 351 218 925 000

ROMANIA

**SAINT-GOBAIN CONSTRUCTION PRODUCTS
ROMANIA S.R.L. - PAM Business Unit**
Str. Tipografilor nr. 11-15
S-Park/Corp - B3 B4 - Sector 1 - Cod 013714
BUCHAREST - Romania
Phone: + 40 21 207 57 37

SLOVAKIA

**SAINT-GOBAIN CONSTRUCTION PRODUCTS
PAM Business Unit**
Stara Vajnorska 139
83102 - BRATISLAVA- Slovakia
Phone: + 421 265 45 69 61

SOUTH AFRICA

**SAINT-GOBAIN CONSTRUCTION PRODUCTS
PAM Business Unit**
N1 Business Park
Corner Olievenhoutbosch Road & Old Johannesburg Road
Samrand - PO BOX 700
GERMISTON - South Africa 1400
Phone: +27 12 657 2800

SPAIN

SAINT-GOBAIN PAM ESPANA
C/ Principe de Vergara, 132 planta 7
28002 - Madrid - Spain
Phone: + 34 91 397 20 00

UNITED ARAB EMIRATES

SAINT-GOBAIN PAM GULF
Jebel Ali Free Zone, Plot S10817
POBOX 261484
Dubai - United Arab Emirates
Phone: + 971 4 8011 800

UNITED KINGDOM

SAINT-GOBAIN PAM UK
Lows Lane - Stanton-by-Dale
ILLKESTON - DERBYSHIRE - DE7 4QU
United Kingdom
Phone: + 44 115 930 5000

VIETNAM

SAINT-GOBAIN PAM VIETNAM
C/O SAINT-GOBAIN VIETNAM
17/F NAM A BANK BUILDING
201-203 Cach Mang Thang 8, Ward 4 - District 3
HO CHI MINH CITY - Vietnam
Phone: +84 8 39 30 72 73

www.pamline.com

SAINT-GOBAIN PAM

Head office

21, avenue Camille Cavallier
54705 PONT-A-MOUSSON CEDEX
FRANCE
Phone : +33 (0) 3 83 80 73 50
Fax : +33 (0) 3 83 80 76 60

Marketing Department –

Water - Sewage - Municipal Castings

21, avenue Camille Cavallier
54705 PONT-A-MOUSSON CEDEX
FRANCE
Phone: +33 (0)3 83 80 67 89

SAINT-GOBAIN



Printed on PEFC certified
paper by a certified printer