

Kit Doppelmuffe mit Flanschstutzen Standard AQB + Dichtung Standard

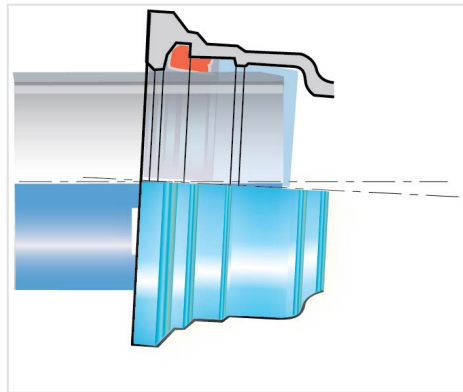

Flanschstutzen

DN	Ø dn	PN	Gesamtgewicht	Artikel-Nr.
60	40	10 16 25 40	9.02 kg	NSA60UD1ANN2-E00
60	60	10 16	9.49 kg	NSA60UD1CNN2-E00
60	60	25 40	9.52 kg	NSA60UD3CNN2-E00
80	60	10 16	11.08 kg	NSA80UD1CNN2-E00
80	60	25 40	11 kg	NSA80UD3CNN2-E00
80	65	10 16	11.56 kg	NSA80UD1DNN2-E00
80	80	10 16 25 40	12.27 kg	NSA80UD1ENN2-E00
100	40	10 16 25 40	12.4 kg	NSB10UD1ANN2-E00
100	60	10 16	12.87 kg	NSB10UD1CNN2-E00
100	60	25 40	12.9 kg	NSB10UD3CNN2-E00
100	65	10 16	13.46 kg	NSB10UD1DNN2-E00
100	80	10 16 25 40	14.47 kg	NSB10UD1ENN2-E00
100	100	10 16	16.1 kg	NSB10UD1FNN2-E00
100	100	25 40	17.3 kg	NSB10UD3FNN2-E00
125	40	10 16 25 40	14.78 kg	NSB12UD1ANN2-E00
125	60	10 16	15.25 kg	NSB12UD1CNN2-E00
125	60	25 40	15.28 kg	NSB12UD3CNN2-E00
125	65	10 16	15.84 kg	NSB12UD1DNN2-E00
125	65	25 40	16.28 kg	NSB12UD3DNN2-E00
125	80	10 16 25 40	16.75 kg	NSB12UD1ENN2-E00
125	100	10 16	18.28 kg	NSB12UD1FNN2-E00

DN	Ø dn	PN	Gesamtgewicht	Artikel-Nr.
125	100	25 40	19.48 kg	NSB12UD3FNN2-E00
125	125	10 16	22.71 kg	NSB12UD1GNN2-E00
125	125	25 40	24.38 kg	NSB12UD3GNN2-E00
150	40	10 16 25 40	17.68 kg	NSB15UD1ANN2-E00
150	60	10 16	18.15 kg	NSB15UD1CNN2-E00
150	60	25 40	18.18 kg	NSB15UD3CNN2-E00
150	65	10 16	18.74 kg	NSB15UD1DNN2-E00
150	65	25 40	19.18 kg	NSB15UD3DNN2-E00
150	80	10 16 25 40	19.65 kg	NSB15UD1ENN2-E00
150	100	10 16	21.28 kg	NSB15UD1FNN2-E00
150	100	25 40	22.48 kg	NSB15UD3FNN2-E00
150	150	10 16	29.04 kg	NSB15UD1JNN2-E00
150	150	25 40	31.08 kg	NSB15UD3JNN2-E00
200	40	10 16 25 40	25.86 kg	NSB20UD1ANN2-E00
200	60	10 16	26.33 kg	NSB20UD1CNN2-E00
200	60	25 40	26.36 kg	NSB20UD3CNN2-E00
200	65	10 16	26.92 kg	NSB20UD1DNN2-E00
200	65	25 40	27.36 kg	NSB20UD3DNN2-E00
200	80	10 16 25 40	27.23 kg	NSB20UD1ENN2-E00
200	100	10 16	29.16 kg	NSB20UD1FNN2-E00
200	100	25 40	30.36 kg	NSB20UD3FNN2-E00
200	150	10 16	34.62 kg	NSB20UD1JNN2-E00
200	150	25 40	36.66 kg	NSB20UD3JNN2-E00
200	200	10	45.46 kg	NSB20UD1KNN2-E00
200	200	16	45.36 kg	NSB20UD2KNN2-E00
200	200	25	46.86 kg	NSB20UD3KNN2-E00
250	60	10 16	32.4 kg	NSB25UD1CNN2-E00
250	60	25 40	32 kg	NSB25UD3CNN2-E00
250	65	10 16	32.56 kg	NSB25UD1DNN2-E00
250	65	25 40	40.5 kg	NSB25UD3DNN2-E00
250	80	10 16 25 40	32.3 kg	NSB25UD1ENN2-E00
250	100	10 16	33.8 kg	NSB25UV1FNN2-E00
250	100	25 40	35 kg	NSB25UV3FNN2-E00
250	150	10 16	40 kg	NSB25UD1JNN2-E00

DN	Ø dn	PN	Gesamtgewicht	Artikel-Nr.
250	150	25 40	42 kg	NSB25UD3JNN2-E00
250	200	10	48 kg	NSB25UD1KNN2-E00
250	200	16	48.2 kg	NSB25UD2KNN2-E00
250	200	25	49.5 kg	NSB25UD3KNN2-E00
250	250	10	56.8 kg	NSB25UD1LNN2-E00
250	250	16	56.8 kg	NSB25UD2LNN2-E00
250	250	25	59.5 kg	NSB25UD3LNN2-E00
300	60	10 16	43.12 kg	NSB30UD1CNN2-E00
300	60	25 40	42.72 kg	NSB30UD3CNN2-E00
300	65	10 16	57.88 kg	NSB30UD1DNN2-E00
300	80	10 16 25 40	42.92 kg	NSB30UD1ENN2-E00
300	100	10 16	43.22 kg	NSB30UV1FNN2-E00
300	100	25 40	44.42 kg	NSB30UV3FNN2-E00
300	150	10 16	50.22 kg	NSB30UD1JNN2-E00
300	150	25 40	52.22 kg	NSB30UD3JNN2-E00
300	200	10	59.72 kg	NSB30UD1KNN2-E00
300	200	16	59.92 kg	NSB30UD2KNN2-E00
300	200	25	61.22 kg	NSB30UD3KNN2-E00
300	250	10	69.32 kg	NSB30UD1LNN2-E00
300	250	16	69.32 kg	NSB30UD2LNN2-E00
300	250	25	72.02 kg	NSB30UD3LNN2-E00
300	300	10	80.52 kg	NSB30UD1MNN2-E00
300	300	16	80.02 kg	NSB30UD2MNN2-E00
300	300	25	83.62 kg	NSB30UD3MNN2-E00

DN mm	Klasse	PFA bar
60	C40	40
80	C40	40
100	C40	40
125	C40	40
150	C40	40
200	C40	40
250	C40	40

DN mm	Klasse	PFA bar
300	C40	40

Produkte

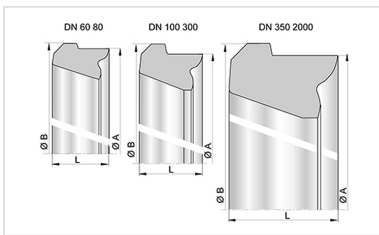

Dichtung Standard für
Rohre und Formstücke