

D400 Narrow Profile Captive Hinged Grating

Proteus includes several features that enhance durability, security, ease of use and water clearing efficiency.

Its unique narrow grating profile avoids excessive clipping by traffic, its patented angled bridge is designed to distribute stress and resist movement resulting in a solution that offers long term performance while focusing on the reduction of whole life costs.

Its large footprint makes it compatible with any standard 450mm diameter gully pot.

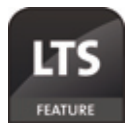

DURABILITY

To aid the reduction of whole life costs, the Proteus design incorporates the Load Transfer System (LTS) to radically improve installation and product lifespan lowering the frequency of reinstatement.



SECURITY

A Captive hinged grating and an integral automatic spring bar locking mechanism combine to offer enhanced anti-theft and security capabilities.



HEALTH & SAFETY

To help reduce work-related injuries, an ergonomic hinged design makes opening simpler, easier and safer.



PERFORMANCE

The unit is non rock and silent in operation. Large multi-directional wedge seatings enhance stability and durability which reduces whole life costs.



ACCREDITATION

Third party certified by BSI and kite marked to the requirements of BS EN 124. Compliant to the requirements of National Highways advice note CD534 and BS7903.



WATER CLEARING EFFICIENCY

A special asymmetrical design in the area adjacent to the kerb disrupts the normal flow to increase the volume of water entering the gully.



SAVE TIME & COST

Available with the Instal Plus frame levelling and installation system as standard.

PROTEUS NARROW PROFILE D400 CAPTIVE HINGED GRATING RANGE	ISSUE NO:2	SGPUK041	DATE: SEPT 2022
Manufactured in the UK to the highest Quality, Environmental and Health & Safety Standards.			

PRODUCT DATASHEET

RECOMMENDED FOR USE IN:

Carriageways carrying continuous heavy traffic in areas requiring efficient removal of surface water

PROTEUS D400 NARROW PROFILE CAPTIVE HINGE GRATING RANGE

SAP Code	SAP Code with Install Plus	Opening Direction	BS EN124 Class	Clear Opening AxB (mm)	Grating Opening (mm)	Over Base C x D (mm)	Depth E (mm)	Waterway Area (cm ²)	CD526 Grating Ref.	Total Mass (kg)	Pallet Quantity
270993	284926	Left Hand	D400	455 x 455	300 x 560	711 x 565	150	997	R	67.5	12
278237	284927	Right Hand	D400	455 x 455	300 x 560	711 x 565	150	997	R	67.5	12

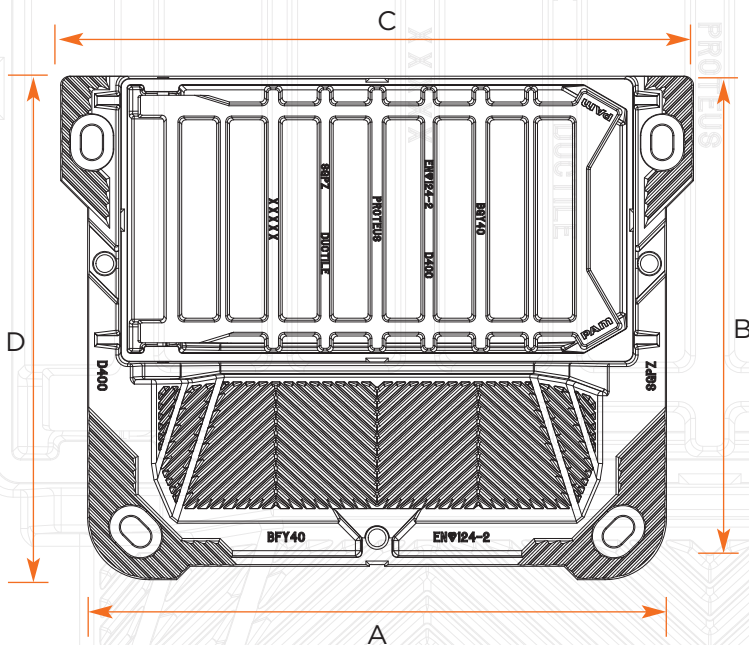

	WATER CLEANING AREA CM ²	
CD534 section 2 paragraphs 2.14.2 & 2.14.3*	50mm from kerbface	117.15
	90mm from kerbface	231.14

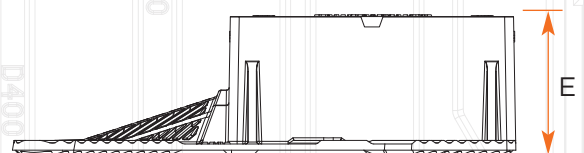

Overbase footprint comparison overlaid on a 450mm diameter gully pot

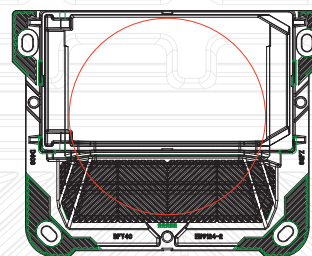

Proteus

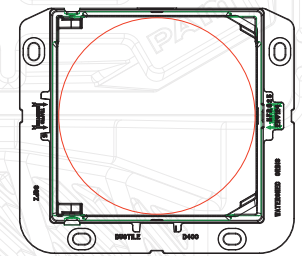

Watershed 450x450mm

Notes

*CD534 Section 2 paragraphs 2.14.2 & 2.14.3 states 'of the total waterway area, there should be a minimum waterway area of 45cm² between the kerb face of the frame and a parallel line 50mm distant, and there should be a minimum waterway area of 65cm² between the kerb face of the frame and a parallel line 90mm distant.'

Grating and frame components are coated in a VOC free water based cationic bituminous emulsion that when dried is classified as non-hazardous and non-toxic.

The information on this sketch is, to the best of our knowledge correct at the time of printing. However, Saint-Gobain are constantly looking at ways of improving their products and services therefore reserve the right to change without prior notice, any of the data shown. Any orders placed will be subject to our Standard Conditions of Sale, available on request.

COPYRIGHT AND DESIGN RIGHT

This drawing is the exclusive property of Saint-Gobain PAM UK and is confidential and must not be reproduced or disclosed for any third party without written consent. It must be used only for the purpose for which it has been issued and is returnable on request.