

STD Ve joint for Fittings STD (16 bar < PFA ≤ 20 bar with steel bolts) DN800-1200

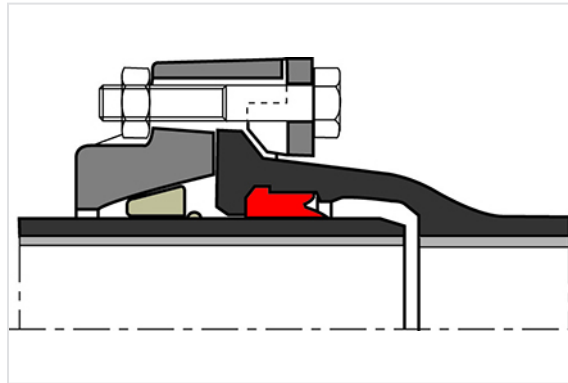

The STANDARD Ve joint is a push-on joint with a weld bead; the water tightness is made by the compression of the elastomer gasket which operates during the assembling by the introduction of the spigot end inside the socket. The anchoring is reinforced by the addition of a gland and of bolts.

In this case, 16 bar < PFA ≤ 20 bar, and for DN 800 to 1200, bolts are in steel cl. 8.8 with support feet.

DN	Class	PFA	Angular deflection	References
1100 mm	(*)	20 bar	1.5 °	

(*) Standard

Field of use:

- For drinking water networks

Main characteristics:

- Elastomer quality: EPDM (EN 681-1)
- Steel bolts (reference JXM27BG1508) and Support feet for standard anchoring joint (reference 144184)
- EN 545
- High angular deflection possible

Material

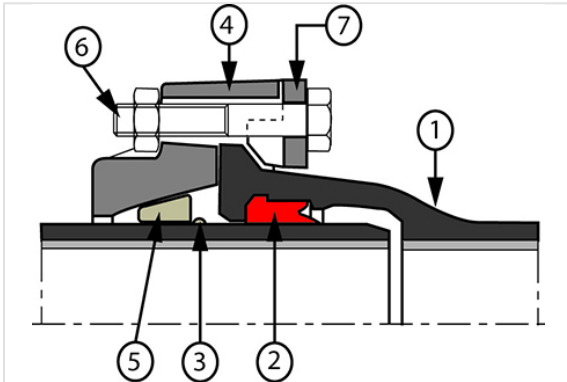

Item	Designation
1	Pipe
2	EPDM joint
3	Weld bead
4	Ductile iron gland
5	Locking ring
6	Steel bolts
7	Ductile iron support feet

The information on this sketch is, to the best of our knowledge correct at the time of printing. However Saint-Gobain are constantly looking at ways of improving their products and services therefore reserve the right to change without prior notice, any of the data shown. Any orders placed will be subject to our Standard Conditions of Sale, available on request.

COPYRIGHT AND DESIGN RIGHT: This drawing is the exclusive property of Saint-Gobain PAM UK and is confidential and must not be reproduced or disclosed for any third party without written consent. It must be used only for the purpose for which it has been issued and is returnable on request