

## Manhole Cover R-TEX Class D400 Round frame - Non Ventilated

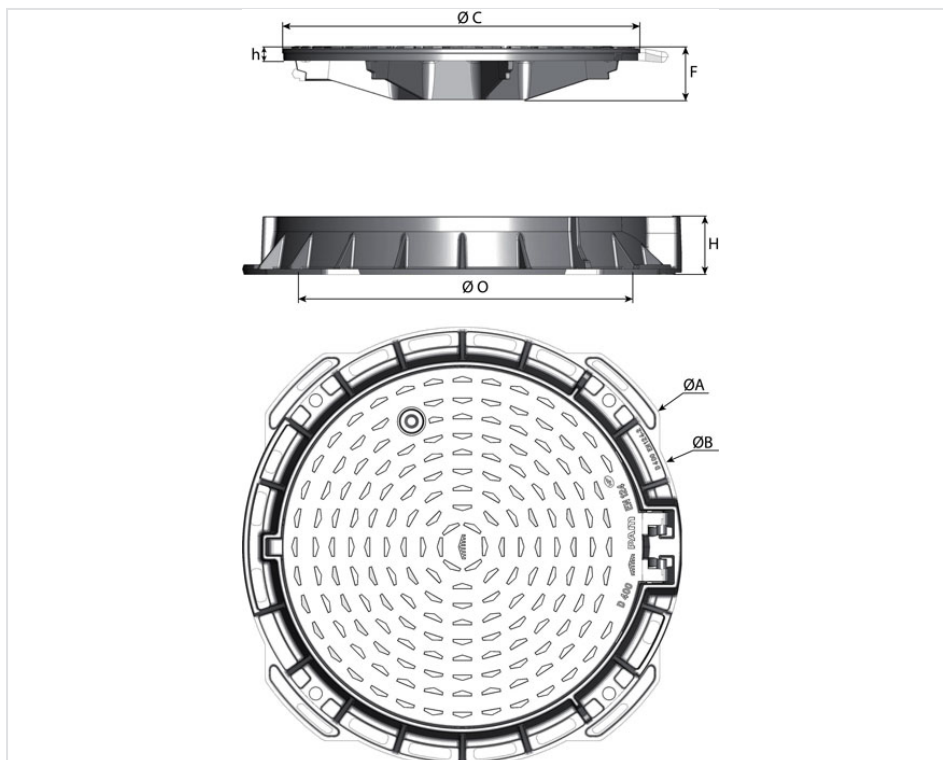

A (mm)	O (mm)	H (mm)	C (mm)	h (mm)	F (mm)	Total Mass (kg)	Cover mass (kg)	Packaging	Marking	References
850x785	600	104	637	26	96	54.60	33		Standard	CDRT60AF



## Material and coating:

- Frame and cover in Ductile Iron EN GJS 400-15: water base
- [Composite ring](#)

## Field of application:

- Group 4 (class D 400) in accordance with EN124-2 standard, carriageways of roads (including pedestrian streets), hard shoulders and parking areas, for all types of road vehicles.
- Medium traffic areas and periodic inspection.

## Origine France Garantie

- This product is made in France in our foundry in Blénod-les-Pont-A-Mousson (54), and is certified Origine France Garantie. This guarantees consumers that the product is made in France in accordance with specifications available on [originefrancegarantie.fr](http://originefrancegarantie.fr). The certification number is: BVCert 6026906.
- *"Origine France Garantie certification is awarded by an independent certification body. Checks are then carried out every year to ensure that the product is indeed 100% made in France and that at least 50% of the product's manufacturing costs (including raw materials) are of French origin".*

## Main characteristics:

- [Automatic locking by ductile iron spring bar](#)
- Hinged cover, opens to 110 °, blocks at 90° when closing
- Frame fitted for optimized bedding
- [Optional cover anti-theft spline](#)
- [Optional locking system](#)

## Linked products



EVA ring

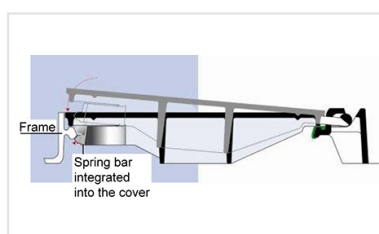

Manhole covers - Locking of the cover by spring bar



Cover anti-theft spline - Manhole cover TEK and B-TEC



1/4 turn locks

*The information on this sketch is, to the best of our knowledge correct at the time of printing. However Saint-Gobain are constantly looking at ways of improving their products and services therefore reserve the right to change without prior notice, any of the data shown. Any orders placed will be subject to our Standard Conditions of Sale, available on request.*

*COPYRIGHT AND DESIGN RIGHT : This drawing is the exclusive property of Saint-Gobain PAM UK and is confidential and must not be reproduced or disclosed for any third party without written consent. It must be used only for the purpose for which it has been issued and is returnable on request*