

UNI STD Vi joint for Pipes and Fittings DN80-700

Standard Universal Vi Locked Ring

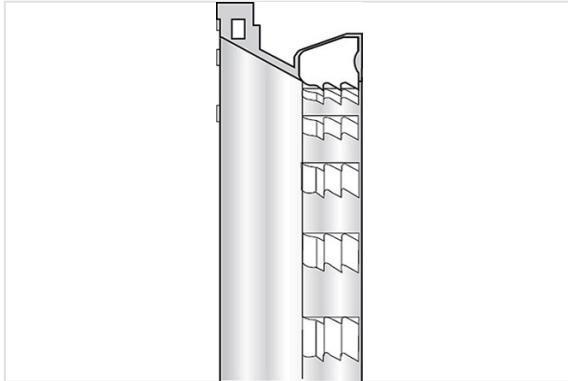

Standard Gasket

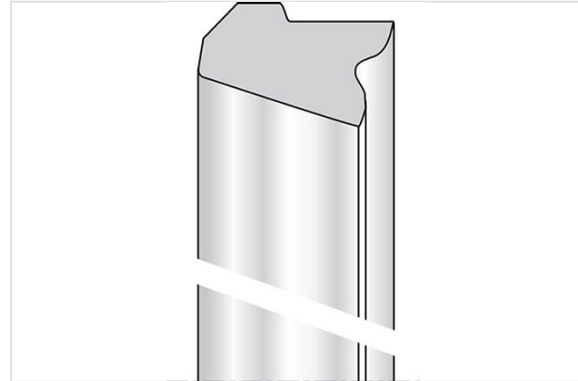

The STANDARD UNIVERSAL VI gasket is a push-on joint with metallic inserts found inside the locked ring.

Details

DN mm	Mass of Universal Vi locking ring kg	References of Universal Vi locking ring	Mass of gasket kg	References of gasket
80	0.150	ANA80CA6	0.148	JSA80BA
100	0.200	ANB10CA6	0.196	JSB10BA
125	0.260	ANB12CA6	0.244	JSB12BA
150	0.310	ANB15CA5	0.285	JSB15BA
200	0.490	ANB20CA4	0.384	JSB20BA
250	0.610	ANB25CA4	0.497	JSB25BA
300	0.780	ANB30CA4	0.712	JSB30BA
350	1.470	JNB35CA	0.898	JSB35BA
400	1.700	JNB40CA	1.077	JSB40BA
450	1.870	JNB45CA	1.323	JSB45BA
500	2.540	JNB50CA	1.544	JSB50BA
600	3.000	JNB60CA	2.162	JSB60BA
700	3.660	110053	2.871	JSB70BA

Linked products

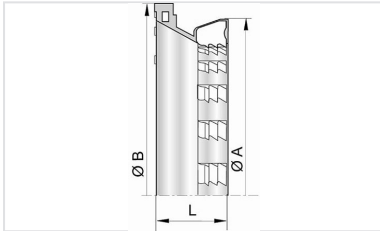

UNI Vi Locked Ring
DN80-700

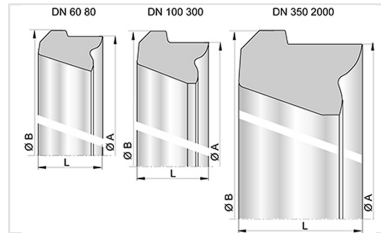

Standard gasket for Pipes
and Fittings DN60-2000

The information on this sketch is, to the best of our knowledge correct at the time of printing. However Saint-Gobain are constantly looking at ways of improving their products and services therefore reserve the right to change without prior notice, any of the data shown. Any orders placed will be subject to our Standard Conditions of Sale, available on request.

COPYRIGHT AND DESIGN RIGHT : This drawing is the exclusive property of Saint-Gobain PAM UK and is confidential and must not be reproduced or disclosed for any third party without written consent. It must be used only for the purpose for which it has been issued and is returnable on request