

**Ductile iron Pipes
and Fittings range**
DN 60 to 2000

**Drinking water supply,
raw water and irrigation**

NEW 2012 EDITION
EN 545:2010
ISO 2531:2009
New pressure classes
New EXPRESS collars

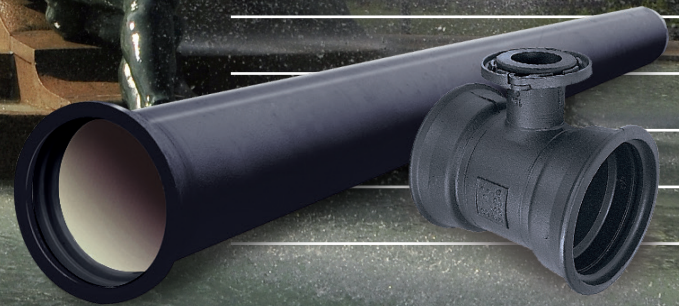

Welcome new ductile iron pipes Standards!

What are the new Standards?

EN 545:2010 is the European Standard used within the European countries and ISO 2531:2009 is the International Standard used for the international trade for ductile iron pipes, fittings and joints for water supply.

The best of international expertise!

These 2 new Standards have been developed with a broad participation of water supply experts of all stakeholders from many countries: Australia, Austria, Belgium, China, France, Germany, India, Italy, Japan, Korea, Spain, Switzerland, United Kingdom and the United States.

The most independent Standards

Approved after European consultations for EN 545:2010 under the authority of European Committee for Standardization (CEN, 31 members countries) and international consultations for ISO 2531:2009 under the authority of International Organization for Standardization (ISO, 162 members countries), these 2 new Standards provide technological, economic and societal benefits.

EN545:2010 Standard is on sale online at the following web sites:

- AFNOR : www.afnor.org
- BSI : www.bsigroup.com

ISO2531:2009 Standard is on sale online at the following web site:

- ISO: www.iso.ch



Pressure classes C and disappearance of thickness classes

Material in contact with drinking water

Sustainable development

Quality management

Improved joint performance

| **Drinking water supply, raw water and irrigation** |

NEW STANDARDS EN 545 & ISO 2531

P 02 ■ CHANGES AND ADVANTAGES

COMMITMENT TO THE WATER MARKET

P 04 ■ PAM

P 06 ■ PAM SOLUTIONS

TECHNICAL SPECIFICATIONS

P 10 ■ THE MECHANICAL PROPERTIES OF DUCTILE IRON

P 14 ■ A COMPLETE RANGE OF ANCHORED OR NON-ANCHORED JOINTS

P 21 ■ AN EXTENSIVE RANGE OF EXTERNAL COATINGS

P 24 ■ INTERNAL LININGS FOR ALL SITUATIONS

P 25 ■ QUALITY, COMPLIANCE

PRODUCTS CATALOGUE

P 26 to 44

PAM COMMITMENTS AND SERVICES

P 45 ■ COMMITMENTS

P 48 ■ SERVICES

For flanged pipes and fittings from diameter 40 to 2000 (PN 10 to 40), please refer to the relevant documentation

The drawings, illustrations and weights given in this brochure are non-contractual.
PAM reserves the right to change product specifications as a result of product improvements without prior notice.

| The new Standards EN 545:2010 and ISO 2531:2009 changes |

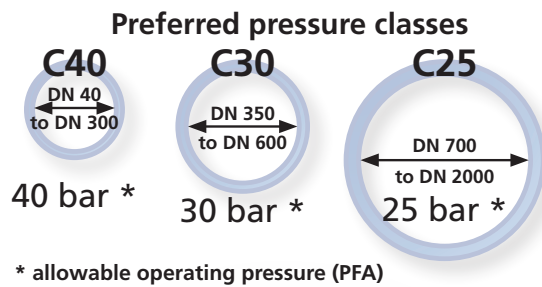

■ PRESSURE CLASSES

- Simple organization in pressure classes for pipes and fittings
- Preferred pressure classes for standard installations
- Additional pressure classes for specific requirements up to 100 bar
- End of thickness classes (K9, etc.)

■ MATERIAL IN CONTACT WITH DRINKING WATER

- The water used in the mortar mix for the internal lining shall comply with Drinking Water Directive 98/83/EC (EN 545 clause 4.5.3.1)
- The pipeline systems have to be in compliance with national regulations covering materials in contact with drinking water

■ SUSTAINABLE DEVELOPMENT

- Approximately 20% reduction in the environmental footprint of products
- Increased durability via recommendation of fields of use and a wide choice of protective external coatings
- External zinc coating shall not be less than 200g/m² (EN 545 clause 4.5.2.2)

■ QUALITY MANAGEMENT

- Conformity of pipes, joints and accessories must be demonstrated by performance tests and factory production control (EN 545 clause 9.1)
- Recommendation to have a quality management system in compliance with the EN ISO 9001:2008 Standard
- EN 545:2010 becomes a Standard system by integrating couplings, flanged adaptors and pipe saddles manufactured for use with ductile iron pipes and fittings (clause 5 and 7)

■ PERFORMANCES

- The new Standards defines the need to ensure that components from different suppliers meet the demanding performance requirements of clause 5 and 7 (ISO 2531)



| The new Standards EN 545:2010 and ISO 2531:2009 changes |

■ PRESSURE CLASSES

- A clearer offer
- Solutions for very high pressures, up to 100 bar
- Calculation method of internal pressure resistance defined in the Standard
- Simple and homogenous correspondence between diameter and allowable operating pressure (PFA)

■ MATERIAL IN CONTACT WITH DRINKING WATER

- Assurance of high quality drinking water
- Guarantee of compliance with national legislations or regulations

■ SUSTAINABLE DEVELOPMENT

- Savings on materials and energy
- Long term reliability of water networks, for lifetimes of over 100 years
- Increased durability

■ QUALITY MANAGEMENT

- High quality certified
- Undeniable proof of compliance
- The highest safety level on the market

	Ductile iron	PVC	PE	Steel*
PFA safety factor	3.00	2.00	1.25	≈2
Standard	EN 545	EN 1452	EN 12201	EN 10214

* Steel pipes are designed on elastic limit, other materials on mechanical strength

■ PERFORMANCES

- Guarantee of a more efficient system
- Added assurance for leak free joint performance



PAM

■ PAM: TIME PROVEN KNOW-HOW

The forerunner of PAM company founded the business in 1856 and has designed and produced iron pipes from that time onwards, a product which underwent improvements in the subsequent years. Pipe spinning allowed pipes to be produced with more uniform shapes and thickness and then the introduction of the ductile iron process on an industrial scale opened up new technical horizons; this is a new material with outstanding properties.



■ The most resistant systems available on the market

Cast irons, with a long history of water supply, can take pride in their record longevity after the passage of centuries.

Once they have coped with sometimes harsh site conditions, pressure pipes, will have a long life when buried which could be subject to various hazards, due to either the operating conditions or the environment, such as overpressure, water hammer, ground movement, or pipe bed destabilisation.

Selection of a pipe with a high safety factor and mechanical aptitude offers a guarantee of long investment life and service continuity.

The mechanical properties of ductile iron, combined with flexible rubber gasket joints, have resulted in the development of robust, flexible pipe systems, capable of withstanding the operating conditions or adverse site conditions without damage. Ductile iron pipes now constitute the best engineered offer on the market of the medium-and large-diameter.

■ Project analysis for proposing SOLUTIONS

As world leader in the manufacture of potable water supply and distribution pipes, PAM has developed expertise in hydraulics, foundry work and metallurgy which have established its reputation.

Over the course of years, the true added value of PAM has been manifested in its ability to define the context of a project and in company with the designer, seek the most suitable project solution.

A multidiscipline team of engineers, technicians, experts and others, provide technical support in design (hydraulic or mechanical calculations, water analyses, soil surveys, etc.), assistance on site or after-sales service.





Systems tailored to their circumstances

Based on a huge databank of references gathered from all the continents, PAM’s researches have culminated in the development of coatings – internal for adaptation to the fluid carried – and external for adaptation to the types of soils traversed. The pipes have become “all soils” pipes.

A wide choice of connections, push-in joints, mechanical joints, anchored or not, permits adaptation to ground configurations or various laying circumstances.

Resistant and perfectly leaktight, available from the smallest to the largest diameters, PAM pipeline systems are synonymous everywhere with adaptability and safety.

Prime asset laying of socket joint pipe systems

Consisting of pipes, fittings and gaskets, ductile iron pipeline systems form a coherent, modular whole enabling all situations to be coped with.

Socket joint pipes are noted for ease of laying in progression with simple site tools, without needing specialised personnel, or site operations like welding or cathodic protection.

Their robustness allows less care being devoted to backfilling and compaction, without sacrificing their expected life.

1,000 cities - 100 capitals

A worldwide vocation

In many regions of the globe, the water resources of a country are still an augury of its chances of development. Since the beginning of the 20th century, PAM has exported its products, taking into account the needs and constraints of its customers both in Europe and farther.

For water supply alone, PAM can reckon on more than 10,000 items of pipes, fittings and joint components, to cope with all situations encountered.

Some 1,000 cities throughout the world, including more than a hundred capital cities, are equipped with a PAM ductile iron potable water network.

Everywhere in the world, PAM works in partnership with the people responsible for the hydraulic infrastructures.

QUALITY ASSURANCE AND ENVIRONMENT

ISO 9001 • The quality management system introduced by PAM has been certified as complying with EN ISO 9001 Standard by the independent third party (Bureau Veritas Certification). This involves specific internal rules concerning the design, manufacture and sale of ductile iron products in accordance with high quality Standards.

ISO 14001 • The PAM’s environmental management system complies with ISO 14001 Standard.

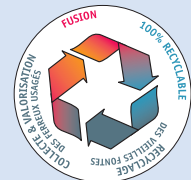

A ductile iron pipe system is a 100% recyclable product.

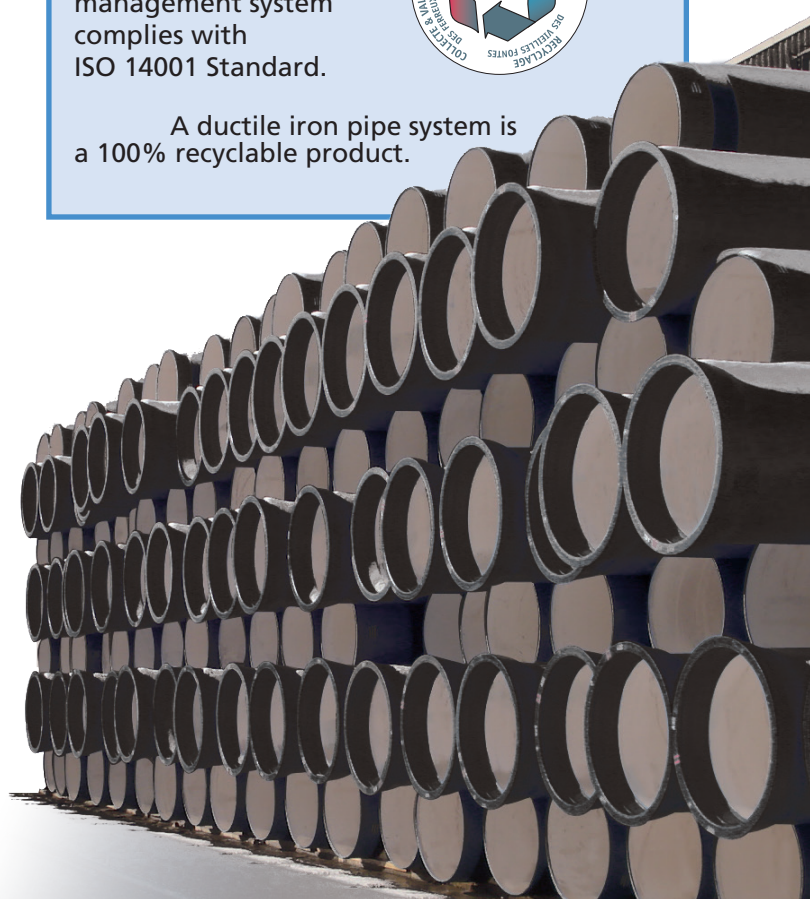

| PAM solutions |

▣ MECHANICAL STRESSING

- > External loads
- > Undermining and unstable grounds
- > Site environments

*Ductility of iron:
a pipe spirally machined creating
a tough and fully elastic spring*



THE PAM SOLUTION

A comprehensive ductile iron pipe system

Ductile iron, obtained by a special magnesium treatment, has an elastic behaviour which confers outstanding mechanical properties upon the metal. Impact resistance: ductile iron is tough.

Bending resistance: ductile iron has a considerable elongation capacity (>10%)* and an elastic limit > 270 MPa.

Ovalisation resistance: rigid, ductile iron pipes deform very little.

All water supply castings, pipes and fittings, are made of ductile iron and benefit from its outstanding mechanical properties.

Being extremely tough and robust, they can withstand high external loading and changes in their environment without damage: ie, ground movements, pipe undermining, bedding destabilisation, without fracturing, cracking or disjointing.

*see page 10.

▣ OPERATING STRESSES

- > High pressures
- > Exceptional regimes



THE PAM SOLUTION

A system with a high safety factor

Above and beyond the mechanical properties of ductile iron, PAM pipes are designed to have a large safety reserve well in excess of that required in service.

They are thus able to withstand, not only high continuous service regimes, but also any over-pressures and water hammer, without deterioration or effect on the life of the installation.

The PFA of ductile iron pipes is designed with a safety factor of 3 (ISO 2531, Annex F).



PIPELINE LEAKTIGHTNESS UNDER PRESSURE

- > Absence of leaks
- > Protection of drinking water conveyed
- > Reliability and continuity of service

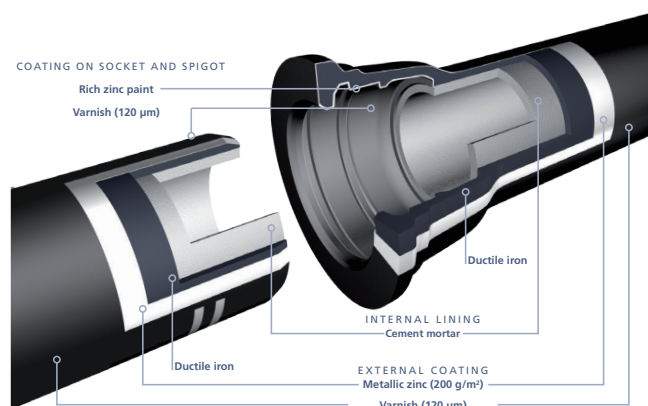

THE PAM SOLUTION

Push-in pipes and elastomer gaskets

Ductile iron pipes are installed as works progress, without welding, simply using standard site tools. The joints are socket and spigot joints with elastomer gasket inserted between the two elements. The gaskets are subjected to severe type tests, and not only confer the utmost modularity on the system but very good operational reliability by guaranteeing leaktightness of the joint.

Leaktightness is achieved by compressing the gasket between two metal components: the contact pressure increases as the internal pressure increases.

FLEXIBILITY OF ELASTOMER GASKETS

- > Ground problems and negotiating obstacles
- > Mechanical strength and flexible chains
- > EN 681.1, ISO 4633.



THE PAM SOLUTION

A complete range of joints

Studies by PAM show that the performance of the gaskets depends on a combination of the rubber hardness, the gasket shape, and the degree of compression.

Elastomer gaskets accommodate significant angular deflection and admit radial displacement under shear loads. These characteristics provide the adaptability of the system which operates like a flexible chain enabling it to follow the curvature of the pipeline, turn around obstacles, and cope with ground problems or environment changes.

Through accumulating experience, PAM has developed a complete range of joints able to cope with all site configurations:

- Push-in or mechanical joints can be self-anchored by locking systems, which are very simple to use if site conditions dictate or if concrete anchor blocks cannot be used.
- They allow the majority of zones to be crossed, even with constraints like steep slopes, rocky areas, laying below the water table and river crossings.

| PAM solutions |

▣ ADAPTABILITY AND DURABILITY

- > External coating performances
- > TT coatings, for very aggressive soils
- > Protection against ageing

▣ DRINKING WATER PROTECTION

- > Internal lining performances
- > Durability of installations
- > Compatibility with drinking water

▣ SYSTEMS EASY TO LIVE WITH

- > Modularity
- > Easy laying of socket joint systems
- > Operational durability

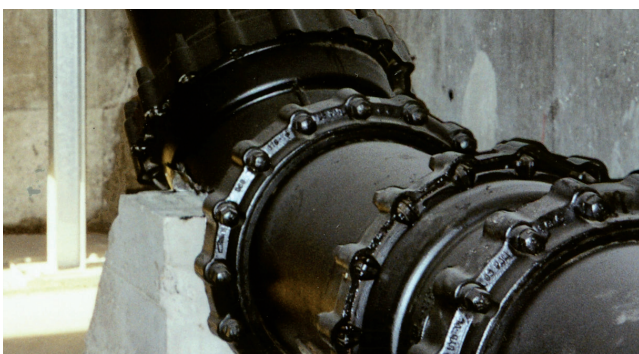

THE PAM RESPONSE

A complete range of external coatings

Culminating from PAM research work, the basic external coating of metallic zinc (200 g/m²) + bitumen finishing coat provides pipe protection through galvanic action. Experience shows it is perfectly suitable for the majority of soils.

If soil surveys confirm significant corrosivity, PAM has designed a range of coatings dedicated for corrosive soils or special applications, known as TT "Tous Terrains" (all soils).

THE PAM SOLUTION

Appropriate internal linings

The standard smooth sound internal protection is a cement mortar applied by a centrifugal process. Being low in roughness, this lining favours flow, limits head loss and protects the water from metal contact.

If the presence of aggressive or soft waters is known or to be feared, PAM recommends a passive polyurethane lining which is better suited to these conditions than the cement mortar. Fittings with special coatings complete the range.

Chemical analysis of the water will confirm the recommendation.

All materials coming into contact with drinking water comply with the most demanding existing regulations.

(See § Drinking water compatibility on p25)

THE PAM SOLUTION

Compatible and homogeneous ranges

Pipes, fittings or joints: PAM offers a wide range of products, coating and lining combinations so that customers can benefit from ductile iron's excellent properties of simplicity and longevity, whatever the site requirements.

The pipe length, ease of assembly, by simple push-in action, and the possibility of self-anchoring allow leaktight reliable systems to be constructed without a specialised team, which stand the test of time.

This guarantees non-premature renewal of hydraulic infrastructures.

| PAM solutions |

▣ DESIGN ASSISTANCE - ADVICE

- > Pre-sales studies
- > Engineering aid tools and software at clients' disposal
- > Sales follow-up

THE PAM SOLUTION

Proximity and assistance

PAM is committed to provide solutions, following projects from their design and to find the most suitable solution within the context and then supply the best options within the range: the aim is to provide information and the necessary tools for designing a reliable durable project.

In order to serve its customers with better service, PAM has local extensive sales network, with the full support of technical and administrative staff to ensure precise and effective follow-up on projects.

The After-Sales Service is based on a multi-disciplinary team able to make rapid and appropriate interventions.

▣ QUALITY AND RELIABILITY

- > Quality Assurance System
- > Conformity with Standards
- > **PAM** Brand
SAINT-GOBAIN

THE PAM SOLUTION

PAM pipe systems are manufactured within organisations complying with EN ISO 9001 certification.

The system products - pipes and fittings - are subjected to individual pressure tests, and comply with the French, European and International standards in force.

Choosing PAM ductile iron pipe systems, means choosing quality and reliability for your equipment.



The mechanical properties of ductile iron

THE MECHANICAL PROPERTIES OF DUCTILE IRON

A new material

The term "cast iron" covers a multitude of Fe-C-Si alloys, classified, amongst other things, according to the shape of the graphite.

Grey (flake graphite) iron is rendered brittle by the presence of the graphite flakes which were also crack initiation points.

By introducing magnesium to the alloy, the graphite precipitates in a spherical form: the discovery of ductile (elastic) iron or spheroidal graphite iron drastically changed the life of cast irons.

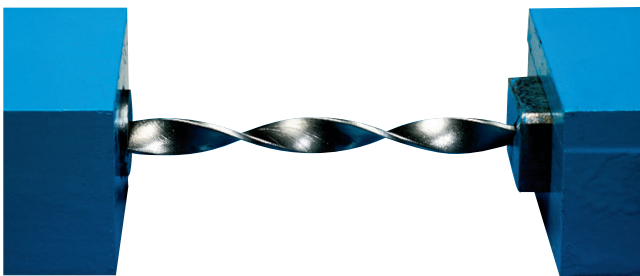

Twisting of a ductile iron bar

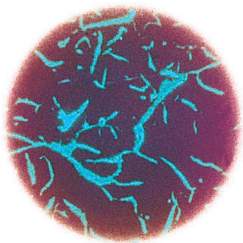

In the old "grey" cast iron, the carbon was present in flake form thus rendering the material brittle.

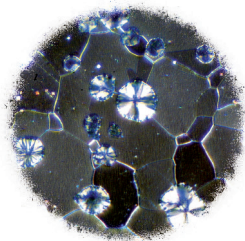

In "ductile" iron, the graphite particles appear as small spheres eliminating any risk of crack propagation lines. The material is no longer brittle. It is "ductile" and resistant.

Mechanical and environmental stresses

Ductile iron pipelines have the advantage of behaviour which is intermediate between flexible and rigid materials. This allows them to benefit mechanically from the advantages of the two.

Buried pipes can be subject in course of time and in unstable grounds, for example, to differential ground settlement, or to undermining by circulating water which destabilises the pipe bed.

The elasticity of ductile iron allows the pipelines to absorb the inevitable stresses or changes undergone by the immediate surround without breaking or disjuncting.

Buried pipes are also mechanically stressed by vertical loads, due to the backfill or traffic, liable to deform the pipes.

It is important therefore to choose a pipe with an adequate safety factor to avoid such breakage, fissuring, bending or ovality problems resulting in high on-costs for the community.

Ductile iron characteristics

Elasticity = $Re \geq 270 \text{ MPa}$

Tensile strength = $Rm \geq 420 \text{ MPa}$

Elongation > 10% for pipes DN 60 to 1000

at break > 7% for pipes DN 1100 to 2000

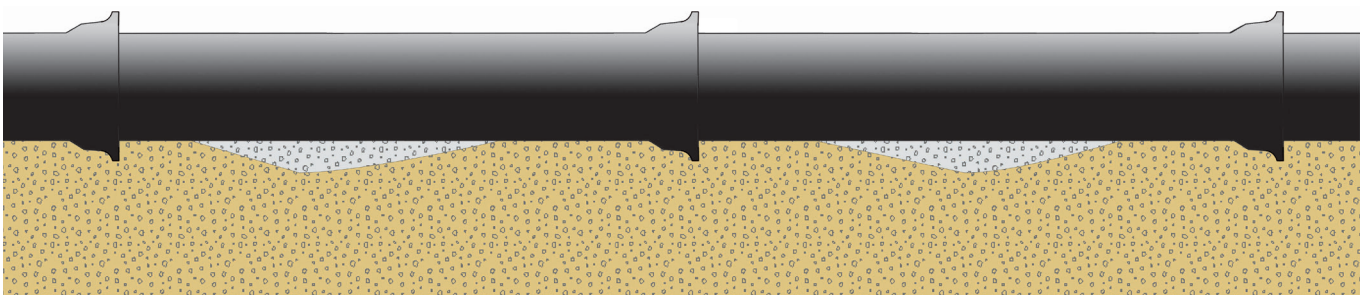

Example of undermining

| The mechanical properties of ductile iron |

□ Performance in unstable ground and longitudinal bending

Buried pipes can sustain significant longitudinal bending stresses, particularly if the pipes are laid on a poor quality bed or if the soils have a poor quality bearing capacity:

- The pipe bed has been destabilised or even undermined, by water table movements,
- The pipeline runs through areas subject to ground movement and/or earthquakes.

The mechanical behaviour of buried pipes can be understood by consideration of the pipe-soil system.

Ductile iron pipes can withstand significant deformation without failure, due to the large elongation capacity possessed by the metal. Tests carried out have demonstrated that they can sustain significant deformation without breaking.

The combination of 6-metre ductile iron pipe length and deflectable elastomer gasket joints allows a steady take-up of mechanical stresses, and provides an excellent performance in unstable soils.

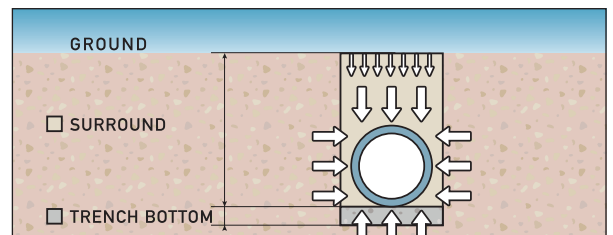
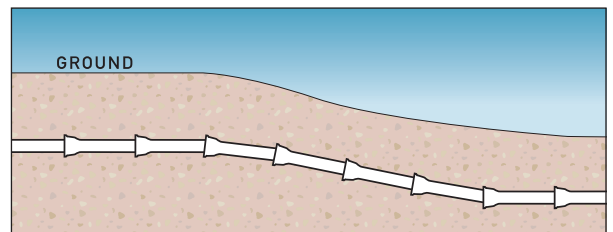
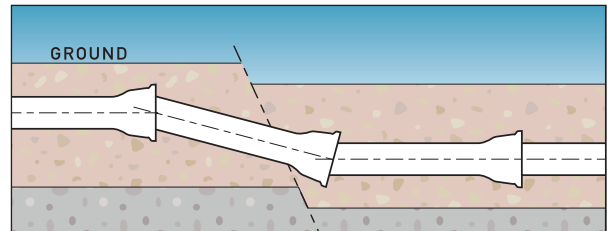

The mechanical properties of ductile iron

Loads on buried pipes and ring stiffness

External loads arise principally through the backfill over the pipe or soil loads (permanent loads) and through intermittent loads or traffic loads.

Site constraints can impose shallow or deep depth of cover and the environment can expose the pipe to repeated traffic loads. It is important therefore to choose a pipe material with sufficient mechanical strength, to avoid failures and service breakdowns.



Safe and economic laying

The vertical loads to which the pipes are subjected are transmitted into the ground through the pipe bedding and surround.

Large forces come into play and there is an interaction between the pipe and the ground.

Generally, in order to play their part, the soil layers must be selected and compacted in accordance with:

- The ability of the pipeline to withstand the local forces: damage or puncturing that could initiate cracks or create defects in the pipe wall;
- The pipe stiffness and strength.

The robustness and strength of ductile iron mains allows the bed preparation and surround to be limited to a strict minimum thus rendering laying safer and more economic.

Depths of cover: range of possibilities

Depths of cover are established with the following assumptions:

- The pipe strength and deformation criteria comply with European Standard EN 545 (wall stress and vertical deflection (ovality)).
- Calculation model conforms with Fascicule 70 (French code of practice).

The table below shows the depths of cover and traffic loads for four different laying examples.

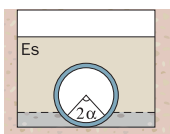

	Case 1	Case 2	Case 3	Case 4
Pipe bed	Flat trench bottom	Flat trench bottom	Selected material	Selected material
Backfill	Not compacted	Compacted & controlled		
Es (bar)	< 3	10	12	20
2α°	60	60	90	90

Es : modulus of reaction of the backfill.

2α : supporting angle.

Minimum and maximum depth of cover • Pipes with traffic loads

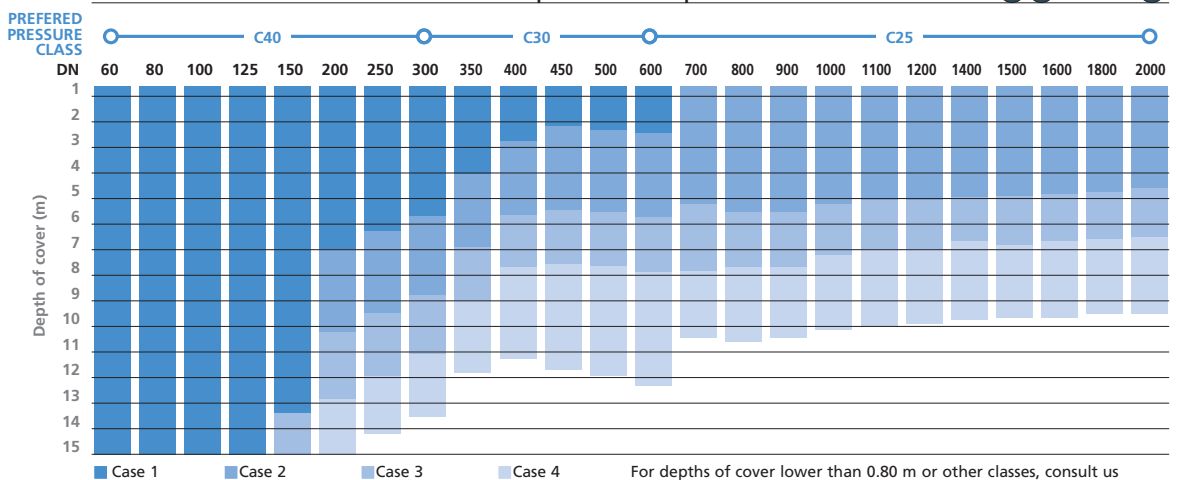

| The mechanical properties of ductile iron |

□ Mechanical strength: a high safety margin confirmed by experience

The excellent mechanical performance of ductile iron pipelines, when subjected to the various forces of buried pressure pipes (earth loads, traffic loads, settlement or small ground movements, accidental overpressures, etc.), is explained by:

- a) The ductility of the material: a large energy absorption capacity is available, beyond the elastic limit of the metal, due to the metal's elongation capacity;
- b) The flexibility of the joints allows the main to follow small ground movements without constraining the pipes;
- c) The high safety factor, used in calculating the wall thicknesses of pipes and fittings. Thus, in accordance with European Standard EN 545 (Annex A) the allowable operating pressure (PFA) is calculated in accordance with:

$$PFA = \frac{\text{Calculated bursting pressure}}{S_f} = \frac{20 \times e \times R_m}{D \times S_f}$$

where **PFA** is the allowable operating pressure (bar)
e is the minimum thickness of the ductile iron wall (mm)
Rm is the tensile strength of ductile iron ($R_m > 420$ MPa)
D is the pipe's external diameter (mm)
S_f is the safety factor ($S_f = 3$)

There is therefore a safety factor of 3 existing between the allowable operating pressure adopted and the calculated bursting pressure.

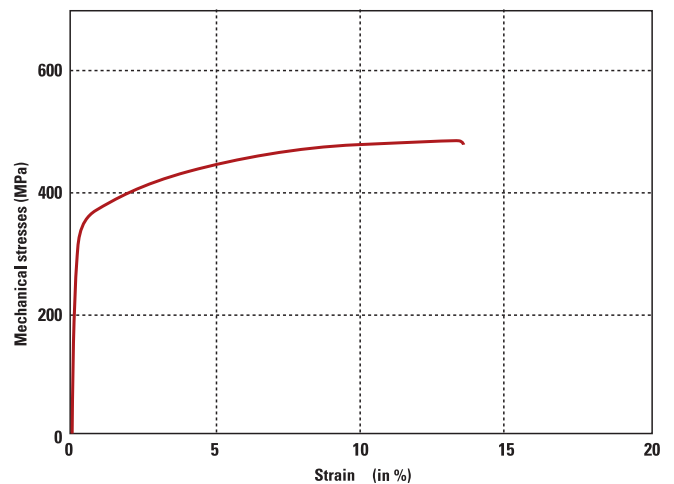

Stress-strain curve of ductile iron

Destructive pressure test on a DN 250 pipe



A complete range of anchored and non anchored joints

COMPLETE RANGE OF ANCHORED OR NON-ANCHORED JOINTS

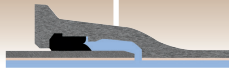
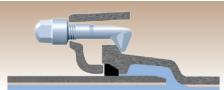
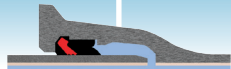
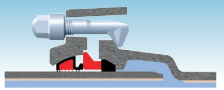
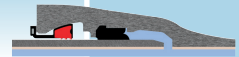
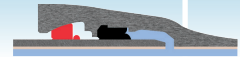
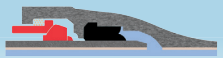
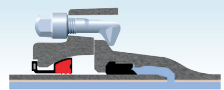
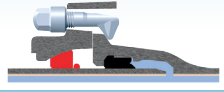
DN 60 / 300	DN 350 / 600	DN 700 / 1200	DN 1400 / 2000	APPLICATION
 STANDARD				PIPES & FITTINGS
 EXPRESS				
 STANDARD <i>Vi</i>				USUAL SITUATIONS
 EXPRESS <i>Vi</i>				
DN 80 ▽	 UNIVERSAL <i>Vi</i>		HIGH PRESSURE	
DN 100 ▽	 UNIVERSAL <i>Ve</i>			
		DN 1400 ▽	HIGH HYDRAULIC THRUST	
		 PAMLOCK		
 STANDARD <i>V+i</i>				SUPPLEMENTARY SELF-ANCHORING
DN 80 ▽	 STANDARD <i>Ve</i>			

JOINT PERFORMANCE

The joint is a key point in a pressure pipeline and must not be a source of weakness. Well designed gasket shape and drastic elastomer selection ensures steady, reliable and durable pipe systems operation whilst rendering it flexible and easy to assemble.

Leaktight joints

Ductile iron pipeline components are joined together by an elastomer gasket providing connection and leaktightness.

Leaktightness is achieved by compressing the elastomer gasket between two metallic elements:

- With mechanical joints, **axial** compression is applied by means of a gland and bolts,
- With push-on joints the compression is **radial**.

It is of utmost interest to the user that a pipeline does not drain external water: ingress of water from the water table could render the water conveyed unsuitable for human consumption.

The gaskets used are usually EPDM rubber; they are selected to keep their physico-chemical characteristics over time, thus ensuring their leaktightness function is perpetuated.

A complete range of anchored and non anchored joints

“Flexible” joints

The elastomer gaskets provide ductile iron pipelines with mechanical flexibility, which constitutes an element of safety when traversing poor consistency or unstable ground (marshy areas, subsidence due to the abstraction of underground water, or mining, consolidation of road hardcores, etc...).

It is advisable to assess the potential for subsidence and to take all precautions to minimise the effect of soil movement on the pipeline. Measurements on site are always recommended.

Experience has shown that when ground movement occurs, a pipeline must be able to follow the deformation caused, instead of trying to resist the often considerable mechanical stresses generated (longitudinal and bending forces).

Socket joints enable the pipeline to act like a flexible chain within the limits of the allowable axial withdrawal. They allow large radius curves to be laid without the use of fittings.

The assemblies which must not reveal any leak, are subjected to the following performance tests specified in European Standard EN 545 (which are higher than those specified in ISO 2531).



Test	Test requirements	Test conditions
Positive internal hydrostatic pressure	Test pressure: (1.5 PFA + 5) bar Test duration: 2 h No visible leakage	Joint of maximum annulus, aligned and withdrawn, with shear load Joint of maximum annulus, deflected
Negative internal pressure	Test pressure : - 0.9 bar* Test duration: 2 h Maximum pressure change during test period: 0.09 bar	Joint of maximum annulus, aligned, with shear load Joint of maximum annulus, deflected
Positive external hydrostatic pressure	Test pressure : 2 bar Test duration: 2 h No visible leakage	Joint of maximum annulus, aligned and withdrawn, with shear load
Cyclic internal hydraulic pressure	24 000 cycles Test pressure: between PMA and (PMA - 5) bar No visible leakage	Joint of maximum annulus, aligned and withdrawn, with shear load

* 0,9 bar below atmospheric pressure (approximately 0,1 bar absolute pressure)

New
Increased angular deflection
for STANDARD joint

Angular deflection

Joint DN	Non Anchored			Anchored				
	STANDARD*	EXPRESS *	UNIVERSAL *	STANDARD Vi*	EXPRESS Vi*	UNI Vi Ve Pk*	STANDARD Ve*	STANDARD V+i*
60	5	5	-	5	4	-	-	-
80	5	5	-	5	4	3	5	-
100	5	5	3	5	4	3	5	-
125	5	5	3	5	4	3	5	-
150	5	5	3	5	4	3	5	-
200	5	4	3	4	3	3	4	-
250	5	4	3	4	3	3	4	-
300	5	4	3	4	3	3	4	-
350	4	3	3	3	-	3	3	3
400	4	3	3	2	-	3	3	3
450	4	3	3	2	-	3	3	3
500	4	3	2	2	-	2° (Uni Vi) 3° (Uni Ve)	3	2
600	4	3	2	2	-	2	3	2
700	4	2	2	-	-	2	2	-
800	4	2	2	-	-	2	2	-
900	4	1.5	2	-	-	1.5	1.5	-
1000	4	1.5	1	-	-	1.2	1.5	-
1100	4	1.5	-	-	-	-	1.5	-
1200	4	1.5	1	-	-	1.1	1.5	-
1400	3	3	-	-	-	1	-	-
1500	3	2	-	-	-	1	-	-
1600	3	2	-	-	-	1	-	-
1800	2.5	1.5	-	-	-	0.8	-	-
2000	2	1	-	-	-	-	-	-

* Maximum angular deflection

A complete range of anchored and non anchored joints

High maximum pressures

In compliance with the European Standard EN 545:2010 and International Standard ISO 2531:2009.

PFA = Allowable operating pressure

Maximum hydrostatic pressure that a component is able to withstand in permanent service.

PMA = Allowable maximum operating pressure • PMA = 1.2 x PFA

Maximum pressure including water hammer that a component is able to withstand occasionally during service.

PEA = Allowable test pressure • PEA = PMA + 5 bar

Maximum hydrostatic pressure that a newly installed component is able to withstand for a relatively short period to ensure the pipeline's integrity and leaktightness.

Non Anchored pipes and fittings

DN	PIPES					FITTINGS								
	Preferred Pressure Class	STANDARD PIPES				Fittings Class	STANDARD FITTINGS ⁽³⁾				EXPRESS FITTINGS ⁽⁴⁾			
		PFA bar	PMA bar	PEA bar	Deflection ⁽²⁾ °		PFA bar	PMA bar	PEA bar	Deflection ⁽²⁾ °	PFA bar	PMA bar	PEA bar	Deflection ⁽²⁾ °
60	C40	40	48	53	5	C100	64	77	82	5	64	77	82	5
80	C40	40	48	53	5	C100	64	77	82	5	64	77	82	5
100	C40	40	48	53	5	C100	64	77	82	5	64	77	82	5
125	C40	40	48	53	5	C64	64	77	82	5	64	77	82	5
150	C40	40	48	53	5	C64	64	77	82	5	50	60	65	5
200	C40	40	48	53	5	C64	64	77	82	5	50	60	65	4
250	C40	40	48	53	5	C50	50	60	65	5	50	60	65	4
300	C40	40	48	53	5	C50	50	60	65	5	40	48	53	4
350	C30	30	36	41	4	C50	50	60	65	4	25	30	35	3
400	C30	30	36	41	4	C40	40	48	53	4	25	30	35	3
450	C30	30	36	41	4	C40	40	48	53	4	25	30	35	3
500	C30	30	36	41	4	C40	40	48	53	4	25	30	35	3
600	C30	30	36	41	4	C40	40	48	53	4	25	30	35	3
700	C25 ^A C30 ^B	25 ^A 30 ^B	30 ^A 36 ^B	35 ^A 41 ^B	4	C30	30	36	41	4	25	30	35	2
800	C25 ^A C30 ^B	25 ^A 30 ^B	30 ^A 36 ^B	35 ^A 41 ^B	4	C30	30	36	41	4	25	30	35	2
900	C25 ^A C30 ^B	25 ^A 30 ^B	30 ^A 36 ^B	35 ^A 41 ^B	4	C30	30	36	41	4	25	30	35	1.5
1000	C25 ^A C30 ^B	25 ^A 30 ^B	30 ^A 36 ^B	35 ^A 41 ^B	4	C30	30	36	41	4	25	30	35	1.5
1100	C25	25	30	35	4	C30	30	36	41	4	25	30	35	1.5
1200	C25	25	30	35	4	C30	30	36	41	4	25	30	35	1.5
1400	C25	25	30	35	3	C30	30	36	41	3	25	30	35	3
1500	C25	25	30	35	3	C25	25	30	35	3	25	30	35	2
1600	C25	25	30	35	3	C25	25	30	35	3	25	30	35	2
1800	C25	25	30	35	2.5	C25	25	30	35	2.5	25	30	35	1.5
2000	C25	25	30	35	2	C25	25	30	35	2	25	30	35	1

⁽²⁾ Maximum angular deflection ⁽³⁾ Consult us for Tee above DN 1400 with branch above 600

⁽⁴⁾ in DN1400-2000 EXPRESS collars only ^A: in NATURAL and HYDROCLASS ranges ^B: in CLASSIC range

A complete range of anchored and non anchored joints

Anchored pipes and fittings - DN 60 - 600

DN	Pipe Class	STANDARD Vi				EXPRESS Vi				Pipe Class	UNIVERSAL Vi				UNIVERSAL Ve			
		PFA	PMA	PEA	Deflection	PFA	PMA	PEA	Deflection		PFA	PMA	PEA	Deflection	PFA	PMA	PEA	Deflection
		bar	bar	bar	°	bar	bar	bar	°		bar	bar	bar	°	bar	bar	bar	°
60	C40	22	26	31	5	22	26	31	4	-	-	-	-	-	-	-	-	-
80	C40	16	19	24	5	16	19	24	4	C100	60	72	77	3	-	-	-	-
100	C40	16	19	24	5	16	19	24	4	C100	56	67	72	3	64	77	82	3
125	C40	16	19	24	5	16	19	24	4	C64	52	62	67	3	64	77	82	3
150	C40	16	19	24	5	16	19	24	4	C64	48	58	63	3	60	72	77	3
200	C40	16	19	24	4	16	19	24	3	C64	43	52	57	3	52	62	67	3
250	C40	16	19	24	4	16	19	24	3	C50	39	47	52	3	46	55	60	3
300	C40	16	19	24	4	16	19	24	3	C50	34	41	46	3	40	48	53	3
350	C30	16	19	24	3	-	-	-	-	C40	25	30	35	3	38	46	51	3
400	C30	16	19	24	2	-	-	-	-	C40	20	24	29	3	35	42	47	3
450	C30	13	16	21	2	-	-	-	-	C40	16	19	24	3	32	38	43	3
500	C30	11	13	18	2	-	-	-	-	C40	16	19	24	2	30	36	41	3
600	C30	10	12	17	2	-	-	-	-	C40	16	19	24	2	30	36	41	2

Anchored pipes and fittings - DN 700 - 2000

DN	Pipe Class	UNIVERSAL Ve				PAMLOCK			
		PFA	PMA	PEA	Deflection ⁽²⁾	PFA	PMA	PEA	Deflection ⁽²⁾
		bar	bar	bar	°	bar	bar	bar	°
700	C30	27	32	37	2	-	-	-	-
800	C30	25	30	35	2	-	-	-	-
900	C30	25	30	35	1,5	-	-	-	-
1000	C30	25	30	35	1,2	-	-	-	-
1200	C25 ^A C30 ^B	20 ^A /25 ^B	24 ^A /30 ^B	29 ^A /30 ^B	1,1	-	-	-	-
1400	C25	-	-	-	-	25	30	35	1
1500	C25	-	-	-	-	25	30	35	1
1600	C25	-	-	-	-	25	30	35	1
1800	C25	-	-	-	-	16	19	24	0,8
2000	C25	-	-	-	-	Please consult us			

⁽²⁾ Maximum angular deflection ^A: in NATURAL and HYDROCLASS ranges ^B: in CLASSIC range

Anchored Pipes and fittings - Supplementary solutions

DN	Pipe Class	STANDARD Ve				Pipe Class	STANDARD V+i			
		PFA	PMA	PEA	Deflection ⁽²⁾		PFA	PMA*	PEA	Deflection ⁽²⁾
		bar	bar	bar	°		bar	bar	bar	°
80	C100	64	77	82	5	-	-	-	-	
100	C100	64	77	82	5	-	-	-	-	
125	C64	64	77	82	5	-	-	-	-	
150	C64	55	66	71	5	-	-	-	-	
200	C64	46	55	60	4	-	-	-	-	
250	C50	35	42	47	4	-	-	-	-	
300	C40	28	34	39	4	-	-	-	-	
350	C30	27	32	37	3	C40	25	30	35	3
400	C30	25	30	35	3	C40	20	24	29	3
450	C30	23	28	33	3	C40	16	19	24	3
500	C30	22	26	31	3	C40	16	19	24	2
600	C30	20	24	29	3	C40	16	19	24	2
700 ⁽³⁾	C25	20	24	29	2	-	-	-	-	
800 ⁽⁴⁾	C25	16 ^A 20 ^B	19 ^A 24 ^B	24 ^A 29 ^B	2	-	-	-	-	
900 ⁽⁴⁾	C25	16 ^A 20 ^B	19 ^A 24 ^B	24 ^A 29 ^B	1.5	-	-	-	-	
1000 ⁽⁴⁾	C25	16 ^A 20 ^B	19 ^A 24 ^B	24 ^A 29 ^B	1.5	-	-	-	-	
1100	C25	16 ^A 20 ^B	19 ^A 24 ^B	24 ^A 29 ^B	1.5	-	-	-	-	
1200	C25	16 ^A 20 ^B	19 ^A 24 ^B	24 ^A 29 ^B	1.5	-	-	-	-	

⁽²⁾ Maximum angular deflection ⁽³⁾ DN 700 : PFA 25 bar with ductile iron bolts ⁽⁴⁾ DN 800 to 1000, PFA 25 bar with steel bolts and C30 pipes

^A: with ductile iron bolts and nuts

^B: with steel bolts and nuts and socket, PFA 25 bar with C30 pipes

STANDARD V+i : to use only on Universal pipe spigot C40.
Do use use on C30 spigots

| A complete range of anchored and non anchored joints |

▣ • STANDARD joint for pipes and fittings

The STANDARD joint is a push-on joint.

Leaktightness is achieved by compressing an elastomer gasket, which is situated in the socket internal seat, and is subjected to radial compression when the spigot of the next pipe is pushed into place.

- Highly reliable under low or high pressure: the contact pressure between the elastomer and the ductile iron increases as the internal pressure increases: the STANDARD gasket is subject to a servo effect. During a destructive pressure test, the pipe bursts, with no leakage detected at the joint.
- Flexibility: significant angular deflection can be accepted and significant axial withdrawal. Recommended for unstable ground and the negotiation of obstacles.
- Electric discontinuity.

• EXPRESS joint for fittings

The EXPRESS joint is a mechanical joint.

Easy to install without any push-in force.

Leaktightness is provided by axial compression of an elastomer gasket, by tightening a gland with iron bolts.

• STANDARD Vi and EXPRESS Vi anchoring solutions for usual situations

In 1994, the launching of STANDARD Vi and EXPRESS Vi with anchoring inserts in the gasket was a significant progress. Now STANDARD Vi is available up to DN 600.

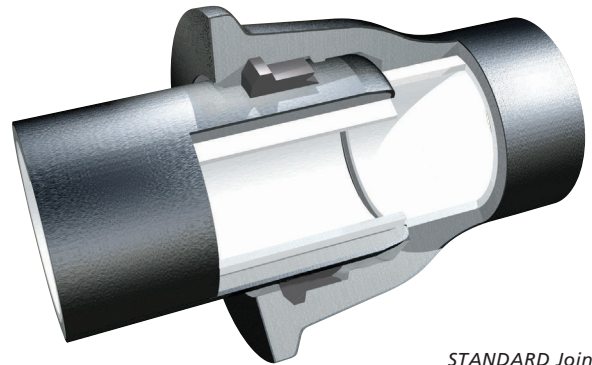

STANDARD Joint for pipes and fittings

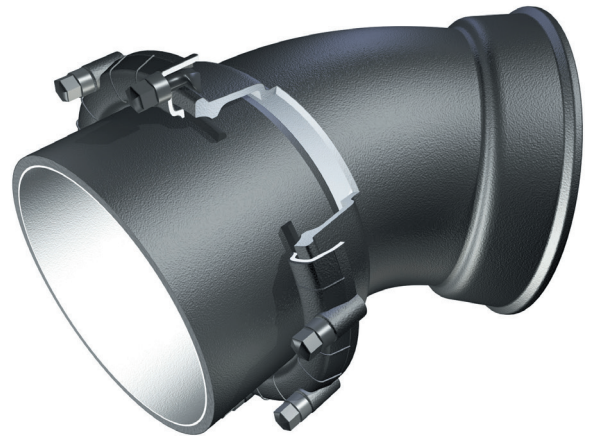

EXPRESS joint for fittings

New
STANDARD Vi is available
up to DN 600

• A new application: horizontal Directional Drilling (HDD)

Horizontal directional drilling is a pipe laying technique for new installations without trench digging or disturbances of surface activities. It is particularly recommended for passing under roads, motorways, roundabouts, railway lines, pedestrian or built-up areas.

The exceptional mechanical and bending strength mean PAM ductile iron pipes can be prescribed for trenchless installations, in diameters up to DN 1000, that is, well in excess of those used up to the present.

ISO 13470 Standard gives specifications for trenchless applications of ductile iron pipe systems.



A complete range of anchored and non anchored joints

ANCHORING SOLUTIONS for high pressure pipe systems

All pipe systems carrying a fluid under pressure are subjected to significant stresses: thrust forces occur at changes in direction, reductions in diameter and at the ends of pipelines. It is essential to counterbalance these forces to prevent any risk of disjuncting either by the use of concrete anchor blocks, or self-anchoring the pipe system.

• Joint anchoring: the UNIVERSAL and PAMLOCK solution for DN 80 to DN 1800

For many years, alternative solutions to concrete anchor blocks have existed for anchoring ductile iron pipes in the ground, but they were rarely used because they relied on the application of a weld bead on site.

PAM now offers an anchoring system for higher pressure rating with a specific range of pipe and fittings called UNIVERSAL.

The UNIVERSAL range fulfills the requirements of European Standard EN 545, ISO 2531 and ISO 10804-1 (specific type test for anchor joints.)

New
UNIVERSAL Ve is available
from DN 100 to DN 1200

New
UNIVERSAL Vi is available
from DN 80 to DN 600

UNIVERSAL Ve joint for pipes or fittings

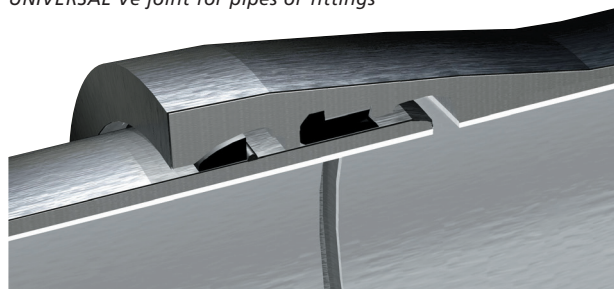

UNIVERSAL and PAMLOCK are boltless anchoring systems with leaktightness and anchoring functions separate.

UNIVERSAL double chamber pipe where the chambers house leaktightness and anchoring functions separately: a traditional STANDARD gasket in the second chamber, and a new rubber anchoring gasket equipped with metallic inserts in the first chamber (UNIVERSAL Vi anchoring gasket) or a ductile iron ring (UNIVERSAL Ve).

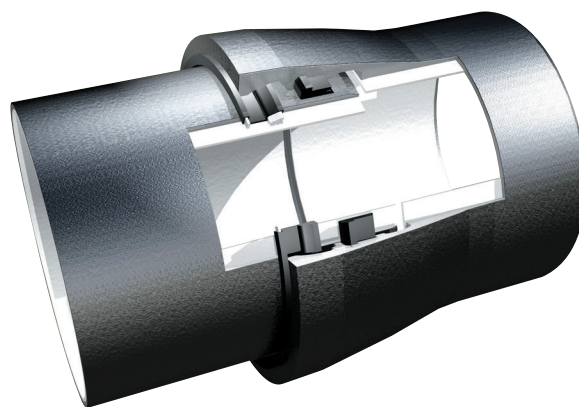

UNIVERSAL Vi joint for pipes or fittings

The PAMLOCK range also allows self-anchoring of large diameter pipelines (DN 1400 to DN 1800).

The PAMLOCK range consists of double chamber pipes: a works applied weld bead, and a ring made up of several segments held together by elastomer connectors.

A conformator designed to transmit the axial force to the internal socket surface by means of shot granules which act like a fluid and distribute the axial forces.

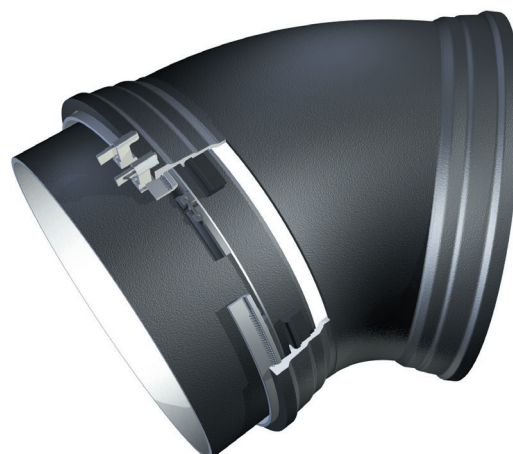

PAMLOCK joint for pipe or fittings

| A complete range of anchored and non anchored joints |

■ OTHER ANCHORING SOLUTIONS

Along with this new type of self-anchored offer, the usual range of weld bead anchoring system - STANDARD Ve pipes and fittings - is still proposed. Although being a little more complex to install, it retains specific areas of application, such as very high pressures, poorly comprehended or controlled dynamic stresses.

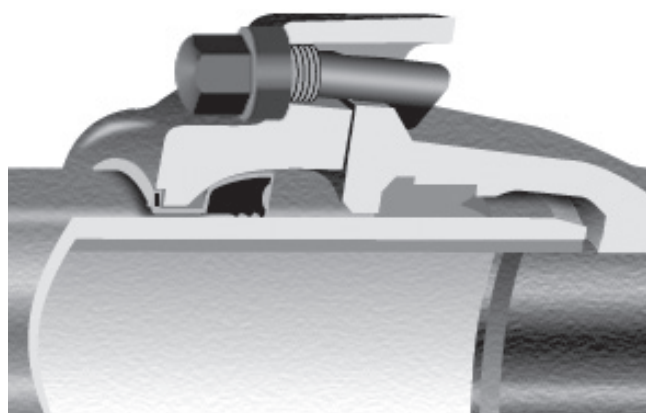

STANDARD V+i joint for fittings.

Classic STANDARD fitting with a rim: anchoring is achieved by adding the anchoring gasket, under a gland, during assembly. Leaktightness is provided by a traditional elastomer gasket situated in the fitting's socket.

Particularly suited to cope with hydraulic forces, anchoring solutions extend the application field of ductile iron pipe systems to geological situations where construction of concrete anchor blocks would be difficult (underwater laying – prior assembly outside the water, as works progress, with self-anchored joints – poor soil cohesion), costly or very complicated, such as urban situations with very congested sub-soils, situations where later reopening of the ground could jeopardise the stability of ancillary structures.

They also allow ductile iron pipes to be used for particular conditions: galleries, steep slopes, horizontal directional drilling, etc...

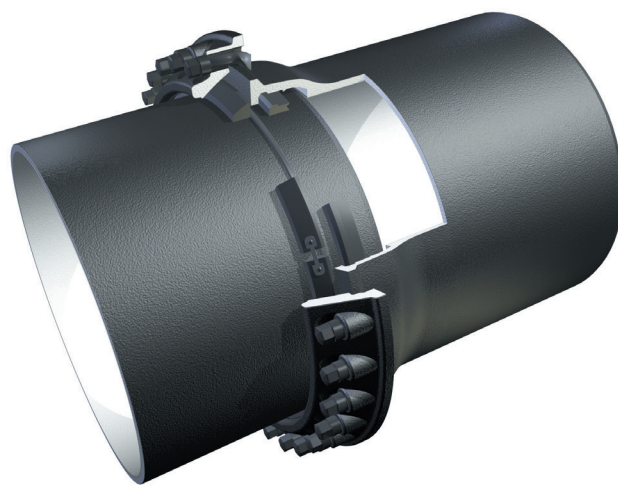

STANDARD Ve pipes or fittings



Refer to the "Self- Anchoring Solutions for ductile iron pipes" catalogue

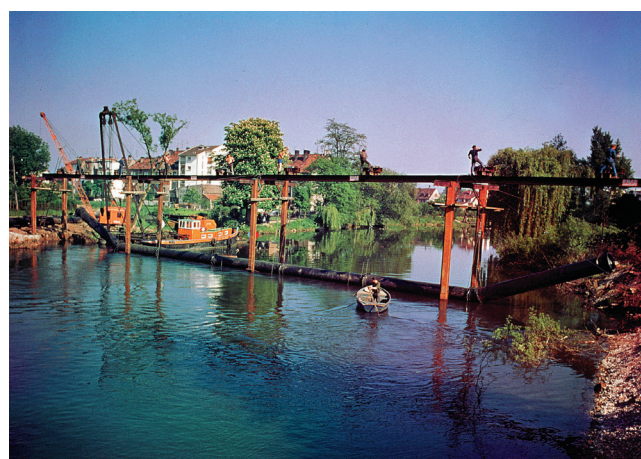

| An extensive range of external coatings |

■ AN EXTENSIVE RANGE OF EXTERNAL COATINGS

■ Basic range: durable zinc-sprayed pipes

Buried pipelines are subjected to many stresses, including corrosivity of soils and backfills. The basic coating for PAM pipes consists of a layer of metallic zinc (200 g/m² minimum) spray applied and covered with a finishing varnish.

This is an active coating suitable for the vast majority of soils.

Standards: EN 545 and ISO 8179-1.

The zinc coating consists of:

- a layer of 200 g/m² metallic zinc applied by spraying,
- a varnish pore sealer: bitumen paint (average thickness of 100 µm) or synthetic varnish.

Zinc metallisation is an active protection due to the galvanic effect of the zinc/iron electrochemical couple.

This coating is available on CLASSIC (in black colour) and HYDROCLASS (in dark blue colour) ranges.

A coating has been developed by PAM. This coating, called ZINALIUM, consists of :

- a layer of 400 g/m² Zn/Al 85/15 alloy
- a finishing pore sealer : blue epoxy paint (average thickness of 100µm) or equivalent.

This new coating improves significantly the life duration and field of use of ductile iron pipes.

This ZINALIUM coating is available on NATURAL range.

Its mechanism of protection of zinc and zinc/ aluminium alloy is twofold:

1 • Formation of a stable protective layer

In contact with the surrounding soil, the metallic zinc slowly transforms into a dense, adherent, impermeable and continuous zinc salts. This acts as a protective barrier.

The pore sealer, whilst permitting galvanic protection and self-healing, favours the formation of a stable and insoluble layer of zinc conversion products.

2 • Self-healing of damage

This mechanism occurs first.

One of the particular features of the external zinc coating is its ability to restore the continuity of the protective layer where small areas of local damage exist.

The Zn⁺⁺ ions migrate through the pore sealer to plug the damage and then convert into stable, insoluble zinc corrosion products.

PAM has chosen to raise the zinc quantity to 200 g/m² (instead of the 130 g/m² prescribed by the ISO8179 Standards).

50% of extra zinc ensures a significant increase in the galvanic protection's life span.

For highly aggressive soils refer to next page.

In experiments carried out at the PAM Research Centre, two identical notches were practised on samples and then immersed in a highly corrosive medium

Non-zinc coated:

The damage worsened and the corrosion (red marks) extends beyond the notch

Zinc coated:

A white line of zinc salts shows that the damage is perfectly plugged.

Zinc spray

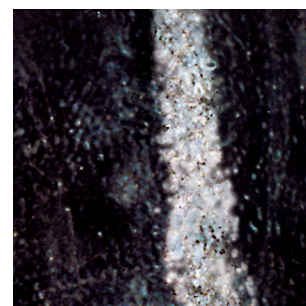
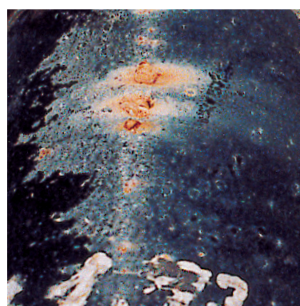
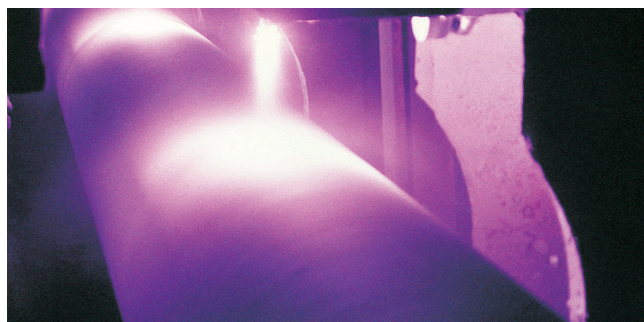

An extensive range of external coatings

Comprehensive range of coatings for highly aggressive soils

In their basic version zinc-coated PAM pipes have an excellent resistance to corrosion which is satisfactory for the majority of applications. The corrosivity of soils should nevertheless be assessed beforehand to see whether special coatings are needed for extra protection.

In order to guarantee the durability of the networks, PAM offers a full range of special coatings from DN 80 to DN 2000, for cases of extremely corrosive areas:

- crossing of sea inlets,
- marsh or peaty areas,
- saline water table,
- polluted or unpredictable soils (industrial waste).

On request PAM technical team will carry out soil surveys to assess their corrosivity and recommend the most appropriate form of protection.

For those of your projects laid in highly corrosive areas, PAM offers a complete pipe system suitable for the conditions:

- DN 80 to 700: **TT PE pipes** with coextruded polyethylene coating (in accordance with EN 14628);
- DN 100 to 2000: **TT PUX pipes** with a spray-applied external polyurethane coating (in accordance with EN 15189);
- DN 100 to 2000: **STANDARD fittings** with internal and external epoxy coating (fusion bonded, in accordance with EN 14901) or polyurethane coating (large diameter in accordance with EN 15655).

Guaranteed integrity

These coatings, known as passive coatings have excellent chemical inertness and act as a protective barrier between the ductile iron and the external environment, completely isolating the material from the corrosive action of the soil.

Pipe integrity is also ensured for bundling and transport by means of special protective devices (straps, caps, etc).

Easy to lay

All the products in the TT PUX range are available in anchored or non-anchored versions. Self-anchored and flanged joints could require special protection. *Please consult us.*

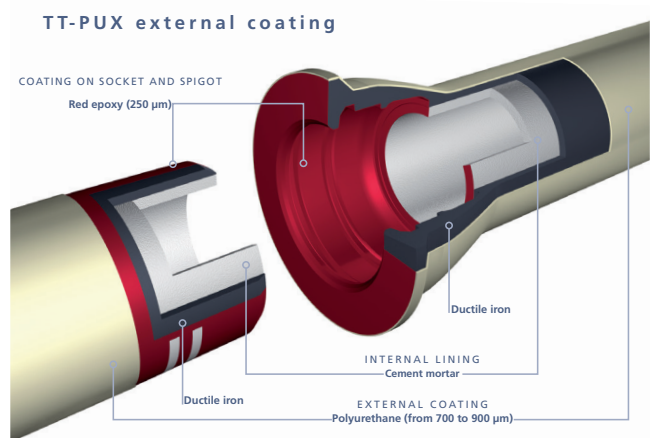
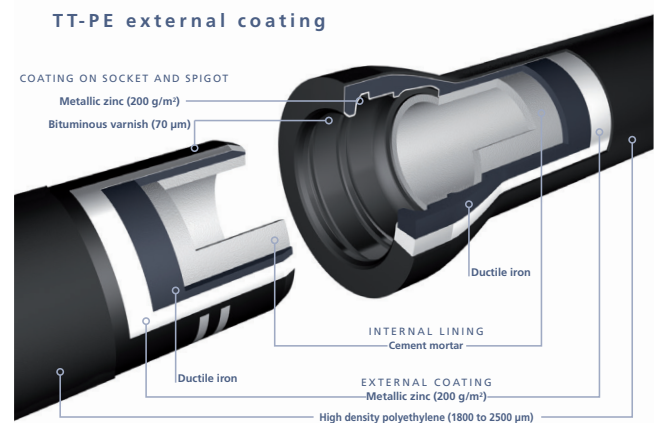

| An extensive range of external coatings |



■ ISOPAM preinsulated pipes DN 100 to DN 600 pipes

These are ductile iron pipes equipped with a works applied heat insulating cladding in accordance with Standard ISO 9394. They are used to:

- **prevent or delay the risk of freezing of the fluid conveyed** (frost protection): *bridge crossings, above-ground installation exposed to adverse weather, shallow depths of cover in cold regions, pumping and outlet pipes in water towers; or,*
- **maintain the fluid's temperature as constant as possible:** *transport of refrigerated water, for example.*

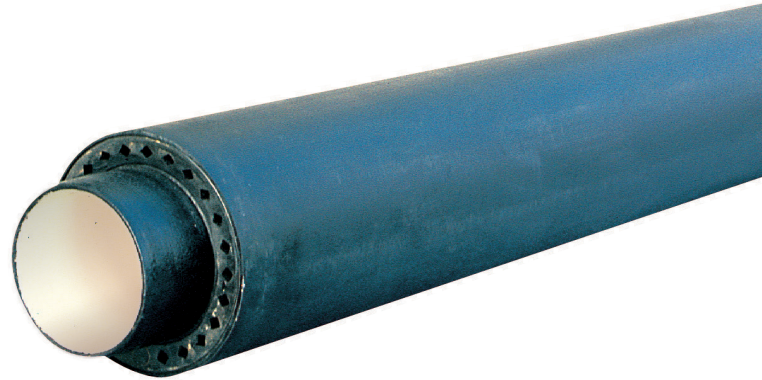

| Internal linings |

■ INTERNAL LININGS FOR ALL SITUATIONS

□ Sulfate resisting cement mortar lining

The basic internal protection for STANDARD pipes is a blast furnace cement mortar lining applied by centrifugal action. This process has the advantage of producing a sound mortar with a smooth internal surface.

This results in the following properties:

- High mortar compactness,
- Good bonding to metal,
- Low surface roughness.



• The cement mortar lining enhances flow

Cement mortar has a very smooth inner surface, which enhances flow and reduces head losses. This mortar guarantees that hydraulic performance is maintained over time (absence of deposits).

The roughness coefficient (COLEBROOK formula) for a pipe alone is $k = 0.03$ mm.

PAM recommends using $k = 0.1$ mm in practice when designing a pipe system in order to take any peculiar head losses in the complete main into account.

• The cement mortar lining protects both pipes and drinking water

• PAM uses only sulfate resisting cement mortar lining (either SRC or blast furnace cement lining) in accordance with Table E.1 column 3 of EN 545:2010.

Protective mechanism

The cement lining does not act merely as a barrier, but protects the iron through a passivation mechanism: during the filling, water gradually soaks into the mortar and absorbs alkaline compounds; by the time it reaches the metal wall, it is consequently non-corrosive.

Crack plugging

Crazing (hydraulic shrinking), or even small cracks occurring during transport, storage or laying, close up through the combined effect of two reactions:

- Rapid mortar swelling on exposure to water,
- Slow hydration of the cement's constituents.

□ Special situations

European Directive 98/83/CEE sets out the quality criteria for waters intended for human consumption.

Whether arising from particular geological context, resulting from treatments, or being conveyed for very lengthy periods in pipelines, aggressive or corrosive waters are a threat to most materials with which they come into contact (aggressive water has a lime-carbonic acid imbalance). Corrosive waters have a low pH (usually below 5.5).

When such circumstances are feared or known to exist, ductile iron pipes may need a passive lining, such as PUR (polyurethane lining in accordance with EN 15655) which will allow the system operator to benefit from all the properties of ductile iron, even under adverse conditions.

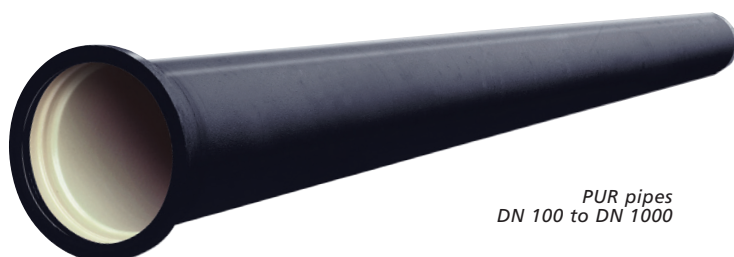

PUR pipes
DN 100 to DN 1000

Quality, compliance

QUALITY

PAM quality procedure extends well beyond the products, and involves the company from design to delivery.

The PAM Quality Assurance system is based on the EN ISO 9001 Standard, which certifies mastery of the manufacturing processes (design, development, production, installation and associated activities). All works manufacturing products in the STANDARD range hold this certificate, issued by a third party.

PAM products comply with European and International Standards (EN and ISO). Compliance with these Standards is certified by independent organisations.

These Standards define the product or service in terms of outcome; every product, pipe or fitting is individually tested at works, by an internal pressure test.

COMPLIANCE

Specification	European Standard	International Standard
Test methods and requirements	EN 545 (1)	ISO 2531 (1)
Cement mortar lining	EN 545 (1)	ISO 4179 (1)
Pipe external zinc coating	EN 545 (1)	ISO 8179-1 (1)
Pipe external Zn/Al 400g/m ²	EN 545 (1)	-
Gaskets - Materials specification	EN 681-1 (1)	ISO 4633 (1)

(1) Compliance certified by an independant accredited third party

COMPATIBILITY WITH DRINKING WATER

The materials used by PAM, and in contact with drinking water (cement mortar, coatings, elastomers, and lubricating pastes), are covered by a French Health Compliance Certificate (ACS) as well as by the british regulation of the DWI (Drinking Water Inspectorate), in the UK and other national regulations for drinking water.

These compliances are certified by independent organisations.



SERVICE AND LOGISTICS

PAM provides an on-the spot service through a team of expert engineers and technicians from its numerous international locations and an important network of representatives.

The sales team feed back information used by product development teams.

Close to their clients, they carry out technical evaluation and customer assistance assignments, such as, design consultancy (hydraulic calculations, engineering calculations, water analyses, soil surveys, etc.), site assistance, after-sales service, and so on...



An international Group, with operations in many countries around the world, PAM uses its extensive knowledge of logistics and transport to serve markets the world over.



**Non-anchored Pressure Class
STANDARD socket pipes DN 60 to 2000**

**Sealing gasket for
STANDARD pipes and fittings DN 60 to 2000**

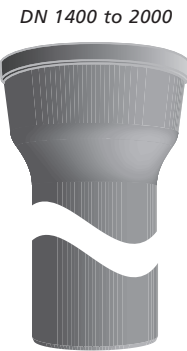
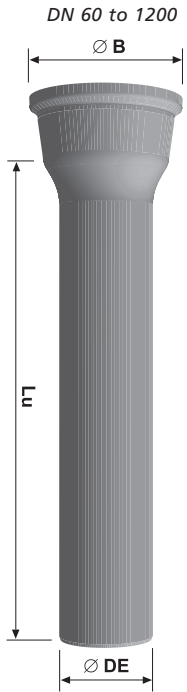

Pipes and fittings DN 60 to 1200



Pipes and fittings DN 1400 to 2000



Pipe Class	Nominal diameter	Average working length	Pipe barrel	Socket	Average metric	Joint
	DN mm	Lu m	Ø DE mm	Ø B mm	Weight kg / m	
C40	60	6	77	144	9.4	STANDARD
	80	6	98	167	12.2	
	100	6	118	188	14.9	
	125	6	144	215	18.3	
	150	6	170	242	22.2	
	200	6	222	295	30.2	
	250	6	274	352	42.2	
	300	6	326	409	55.6	
C30	350	6	378	464	68.8	
	400	6	429	516	79.4	
	450	6	480	574	93.8	
	500	6	532	629	111.2	
	600	6	635	738	150.6	
C25	700	6.955	738	863	186.2	
	800	6.950	842	974	229.0	
	900	6.950	945	1082	276.2	
	1000	6.955	1048	1191	330.6	
	1100	8.190	1151	1300	395.4	
	1200	8.185	1255	1412	461.3	
	1400	8.170	1462	1592	634.3	
	1500	8.160	1565	1710	720.3	
	1600	8.160	1668	1816	807.5	
	1800	8.150	1875	2032	995.1	
2000	8.130	2082	2259	1210.0		

DN mm	Weight kg
60	0.11
80	0.15
100	0.20
125	0.24
150	0.29
200	0.38
250	0.50
300	0.71
350	0.90
400	1.10
450	1.32
500	1.54
600	2.16
700	2.87
800	3.67
900	4.61
1000	5.59
1100	7.68
1200	9.34
1400	15.50
1500	19.80
1600	21.05
1800	27.72
2000	29.00

NB: for other pressure classes, please consult us.

Non-anchored double socket bends

■ STANDARD DN 60 to 2000 / ■ EXPRESS DN 60 to 1200

DN	1/4		1/8		1/16		1/32	
	Lu mm	Weight kg	Lu mm	Weight kg	Lu mm	Weight kg	Lu mm	Weight kg
	STD	EXP	STD	EXP	STD	EXP	STD	EXP
60	75	75	6.2	6.4	76	76	6.5	6.7
80	91	91	7.6	8.7	56	56	7	8.1
100	105	102	10.0	6.8	65	60	8.9	6.0
125	133	130	13.9	9.0	83	65	12.3	7.6
150	152	150	18.1	11.5	92	75	15.6	9.5
200	200	200	29.2	18.8	100	95	23.7	14.6
250	252	250	49.6	33.5	139	115	40.5	25.9
300	304	280	72.7	43.1	167	150	59	35.6
350	390	390	115	95	168	168	69	72
400	436	436	141	140	189	189	89	91
450	482	482	150	170	216	216	118	120
500	525	525	216	215	220	220	146	155
600	624	624	311	312	283	283	208	234
700	670	-	584	-	335	335	311	312
800	735	-	696	-	364	364	414	417
900	880	-	800	-	403	403	545	551
1000	1000	-	1461	-	440	439	703	649
1100	-	-	-	-	540	540	993	993
1200	-	-	-	-	537	537	1015	1033
1400	-	-	-	-	522	-	1555	-
1500	-	-	-	-	572	-	1815	-
1600	-	-	-	-	563	-	2089	-
1800	-	-	-	-	642	-	3126	-
2000	-	-	-	-	685	-	3702	-

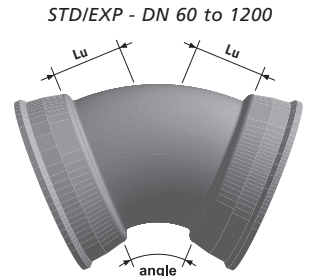

■ EXPRESS mechanical joint assembly / Fittings DN 60 to 1200

DN	Sealing gasket	Gland	Ductile iron bolts		Total accessories
	Weight / kg	Ø ext / mm	Ø / mm	Nbr	
60	0.04	226	22	2	2.8
80	0.06	249	22	3	4.0
100	0.08	270	22	3	4.3
125	0.12	290	22	3	4.5
150	0.14	324	22	4	5.6
200	0.20	364	22	5	7.2
250	0.25	417	22	6	8.8
300	0.35	474	22	7	11.1
350	0.46	529	22	8	12.6
400	0.52	582	22	9	15.0
450	0.66	669	27	8	23.5
500	0.73	725	27	10	28.1
600	1.05	836	27	12	36.5
700	2.60	955	27	16	53.2
800	3.30	1068	27	18	64.5
900	4.20	1178	27	20	78.0
1000	5.20	1289	27	24	94.2
1100	6.10	1400	27	26	114.6
1200	7.40	1512	27	30	130.1

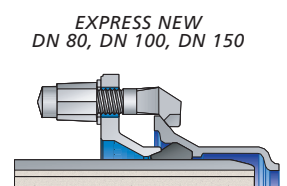
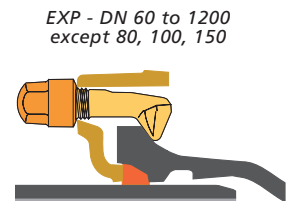

Non-anchored double socket tees with flanged branch

■ STANDARD DN 60 to 2000 / ■ EXPRESS DN 60 to 1200

DN body	dn branch	Lu mm	Hu mm	STANDARD				EXPRESS			
				Weight with flange				Weight with flange			
				PN 10 kg	PN 16 kg	PN 25 kg	PN 40 kg	PN 10 kg	PN 16 kg	PN 25 kg	PN 40 kg
60	40*	154	141	8.8	8.8	8.8	8.8	9.4	9.4	9.4	9.4
	60*	154	161	9.7	9.7	9.3	9.3	10.3	10.3	9.9	9.9
80	40*	145	149	10.2	10.2	10.2	10.2	11.4	11.4	11.4	11.4
	60*	145	169	11.1	11.1	10.7	10.7	12.3	12.3	11.9	11.9
	65*	145	174	11.5	11.5	11.7	NC	12.8	12.8	12.4	12.4
	80*	183	165	12.5	12.5	12.5	12.5	13.8	13.8	13.8	13.8
100	40*	150	161	12.0	12.0	12.0	12.0	13.2	13.2	13.2	13.2
	60*	150	181	12.9	12.9	12.5	12.5	14.1	14.1	13.9	13.9
	65*	150	186	13.3	13.3	NC	NC	14.6	14.6	14.4	14.4
	80*	185	177	14.5	14.5	14.6	14.6	15.8	15.8	15.8	15.8
125	100*	210	180	16.4	16.4	17.0	17.0	17.2	17.2	17.7	17.7
	40*	150	164	14.3	14.3	14.3	14.3	15.2	15.2	15.2	15.2
	60*	150	184	15.2	15.2	14.8	14.8	16.1	16.1	15.7	15.7
	65*	150	189	15.6	15.6	15.8	15.8	16.6	16.6	16.2	16.2
	80*	165	195	16.8	16.8	16.8	16.8	17.7	17.7	17.7	17.7
	100*	190	200	18.5	18.5	19.0	19.0	19.5	19.5	20.0	20.0
150	125*	267	200	23.0	23.0	23.9	23.9	23.0	23.0	23.9	23.9
	40*	154	176	17.1	17.1	17.1	17.1	18.9	18.9	18.9	18.9
	60*	154	196	18.0	18.0	17.6	17.6	20.0	20.0	19.6	19.6
	65*	154	201	18.5	18.5	18.6	18.6	20.5	20.5	20.0	20.0
	80*	165	210	19.6	19.6	19.6	19.6	21.5	21.5	21.5	21.5
	100*	190	215	21.4	21.4	21.9	21.9	24.0	24.0	24.5	24.5
	125*	220	210	23.8	23.8	24.7	24.7	25.5	25.5	26.4	26.4
200	150*	305	220	29.5	29.5	30.5	30.5	30.5	30.5	31.5	31.5
	40*	159	209	25.1	25.1	25.1	25.1	25.5	25.5	25.5	25.5
	60*	159	229	26.0	26.0	25.6	25.6	26.5	26.5	26.1	26.1
	65*	159	234	26.5	26.5	26.6	26.6	27.0	27.0	26.6	26.6
	80*	170	240	27.0	27.0	27.0	27.0	28.0	28.0	28.0	28.0
	100*	195	245	29.1	29.1	29.6	29.6	30.0	30.0	30.5	30.5
	125*	220	240	31.6	31.6	32.5	32.5	33.0	33.0	33.9	33.9
	150*	250	245	34.9	34.9	35.9	35.9	36.0	36.0	37.0	37.0
250	200*	360	260	44.7	44.6	47.0	48.8	45.5	45.4	46.9	46.9
	60*	164	272	38.9	38.9	38.5	38.5	39.2	39.2	39.2	NC
	65*	164	272	39.3	39.3	39.4	39.4	39.7	39.8	38.8	NC
	80*	234	250	43.6	43.6	43.6	43.6	45.1	45.1	45.1	NC
	100*	234	270	43.4	43.4	43.9	43.9	32.5	32.5	33.0	46.5
	150*	251	280	49.5	49.5	50.5	50.5	50.7	50.7	51.7	NC
	200*	344	290	60.3	60.2	61.4	62.1	62.0	61.9	63.4	NC
300	250*	404	300	69.6	69.2	72.1	NC	72.6	72.2	75.1	NC
	60*	237	297	56.3	56.3	55.9	55.9	56.8	56.8	56.4	NC
	65*	237	297	56.7	56.7	NC	NC	57.3	57.3	NC	NC
	80*	237	298	57.4	57.4	57.4	57.4	58.3	58.3	58.3	NC
	100*	237	300	58.1	58.1	58.6	58.6	40.0	40.0	40.5	NC
	150*	347	310	71.2	71.2	72.2	72.2	72.2	72.2	73.2	NC
	200*	347	320	75.7	75.4	77.1	77.5	77.0	76.9	78.4	NC
300	250*	467	305	89.4	89.0	91.9	108.7	91.6	91.2	94.5	NC
	300*	467	340	97.9	97.2	100.8	NC	101.0	100.3	103.9	NC

*rotatable flanges

Non-anchored double socket tees with flanged branch
■ STANDARD DN 60 to 2000 / ■ EXPRESS DN 60 to 1200

DN body	dn branch	Lu mm	Hu mm	STANDARD			EXPRESS			
				Weight with flange			Weight with flange			
				PN 10 kg	PN 16 kg	PN 25 kg	PN 10 kg	PN 16 kg	PN 25 kg	
350	60*	148	322	63	63	63	62	62	62	
	65*	NC	NC	NC	NC	NC	NC	NC	NC	
	80*	194	310	72	72	72	70	70	70	
	100*	Washout Tee see page 31								
	150*	314	340	87	87	88	86	86	86	
	200*	314	350	91	91	92	90	90	99	
	250*	369	360	104	103	106	102	101	104	
	300*	485	370	120	119	123	109	110	-	
350*	485	380	131	132	138	129	130	136		
400	80*	195	340	80	80	80	83	83	83	
	100*	Washout Tee see page 31								
	150*	315	370	100	100	101	100	100	101	
	200*	315	380	105	105	106	8	98	99	
	250*	429	390	125	125	127	117	116	119	
	300*	429	400	133	134	137	121	121	124	
	400*	545	420	162	166	175	164	169	178	
450	100*	Washout Tee see page 31								
	150*	315	400	122	122	103	108	108	109	
	200*	315	410	115	115	116	138	138	140	
	250*	600	420	129,7	129	132	144	143	146	
	300*	600	430	156,3	156	159	150	150	153	
	400*	600	450	175	188	188	192	196	205	
450*	600	460	172	178	186	201	207	214		
500	100*	Washout Tee see page 31								
	150*	325	430	143	143	144	150	150	151	
	200*	325	440	147	147	148	154	154	155	
	250*	443	450	173	173	175	179	178	181	
	300*	443	460	181	180	184	192	192	195	
	400*	555	480	215	219	228	221	226	235	
500*	675	500	258	271	277	264	277	283		
600	100*	Washout Tee see page 31						185,5	185	186
	200*	Washout Tee see page 31								
	300*	452	520	228	228	231	236	235	239	
	400*	570	540	271	275	284	278	283	292	
	600*	800	580	373	398	401	381	406	409	
700	150*	365	520	262	262	263	262	262	263	
	200*	365	525	265	265	266	266	266	267	
	250*	Washout Tee see page 31								
	400*	585	555	347	351	360	347	351	360	
	600*	915	585	474	499	502	474	499	502	
800	700	915	600	491	499	527	491	499	527	
	150*	355	580	332	332	333	330	330	331	
	200*	355	585	335	335	336	321	321	323	
	250*	Washout Tee see page 31								
	400*	575	615	430	435	444	429	433	442	
	600*	1015	645	617	642	645	614	639	642	
900	800	1015	675	663	674	715	661	672	713	
	200*	375	645	420	419	422	419	419	420	
	250*	Washout Tee see page 31								
	400*	595	675	532	536	545	530	535	544	
	600*	1145	705	798	823	826	797	822	825	
900	1145	750	867	878	926	865	876	924		

STD/EXP - DN 60 to 1200

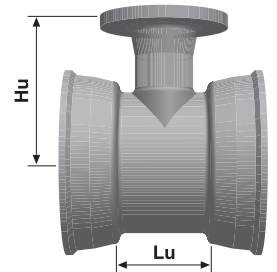

STD - DN 1400 to 2000



Particular feature of washout tee: connection geometry between branch and body of flared shape.

*rotatable flanges

N C: Consult us

Non-anchored double socket tees with flanged branch
STANDARD DN 60 to 2000 / EXPRESS DN 60 to 1200

STD/EXP - DN 60 to 1200

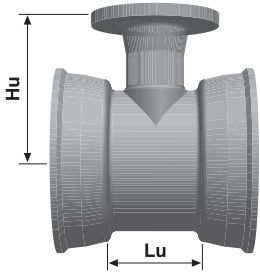

STD - DN 1400 to 2000



Particular feature of washout tee: connection geometry between branch and body of flared shape.

DN body	dn branch	Lu mm	Hu mm	STANDARD			EXPRESS		
				Weight with flange			Weight with flange		
				PN 10 kg	PN 16 kg	PN 25 kg	PN 10 kg	PN 16 kg	PN 25 kg
1000	150*	379	705	447	447	447	451	451	452
	200*	379	705	510	510	512	453	453	454
	250*	Washout Tee see page 31							
	300*	598	720	570	569	574	574	-	579
	400*	598	735	639	644	653	582	586	595
	600*	1258	765	1007	1032	1035	950	975	978
	1000	1258	825	1115	1137	-	1058	1080	1143
1100	200*	822	883	911	910	-	873	873	-
	250*	Washout Tee see page 31							
	300*	822	840	910	909	-	886	-	-
	400*	822	835	999	-	-	894	899	-
	600*	822	865	907	-	-	915	940	-
	700	1245	900	NC	-	-	NC	-	-
	800	1245	915	NC	-	-	1341	-	-
	900	1245	930	NC	-	-	NC	-	-
1200	1000	1245	920	NC	-	-	1351	1373	-
	1100	1245	907	NC	-	-	1621	1651	-
	200*	855	883	949	949	950	-	949	-
	250*	Washout Tee see page 31							
	300*	855	840	927	927	931	952	948	-
	400*	855	835	938	943	-	942	947	-
	600*	855	865	952	977	980	971	996	-
	700	1245	900	NC	-	-	NC	-	-
	800	1245	915	1336	1353	-	NC	-	-
	900	1245	930	1378	1397	-	NC	-	-
	1000	1480	920	-	-	1532	1357	1380	-
1400	1100	1480	907	-	2047	-	NC	-	-
	1200	1480	950	1587	1732	-	1703	1760	-
	400*	1010	960	Washout Tee see page 31			-	-	-
	600*	1010	980	1542	1567	-	-	-	-
	800	1950	1040	NC	-	-	-	-	-
	900	1950	1040	NC	-	-	-	-	-
	1000	1950	1040	NC	-	-	-	-	-
1500	1200	1950	1040	-	-	2346	-	-	-
	1400	1950	1040	NC	-	-	-	-	-
	400*	1110	960	Washout Tee see page 31			-	-	-
1600	600*	1110	980	1790	1815	-	-	-	-
	1500	2050	1100	NC	-	-	-	-	-
	300*	1050	1050	1977	1967	-	-	-	-
	400*	1050	1100	Washout Tee see page 31			-	-	-
	500*	1050	1075	1989	-	-	-	-	-
1800	600*	1050	1090	1997	2022	-	-	-	-
	1000	1505	1150	-	2458	-	-	-	-
	1600	2170	1240	NC	-	-	-	-	-
	200*	1140	258	NC	-	-	-	-	-
	300*	1155	258	2320	-	-	-	-	-
	400*	1300	1300	Washout Tee see page 31			-	-	-
2000	600*	1300	1200	NC	-	-	-	-	-
	800	1360	1230	2704	-	-	-	-	-
	900	1360	1245	NC	-	-	-	-	-
	1800	2485	1380	NC	-	-	-	-	-
	300*	1265	290	3201	3201	-	-	-	-
2000	400*	1280	290	NC	-	-	-	-	-
	500*	1295	290	3221	3235	-	-	-	-
	600*	1110	1315	Washout Tee see page 31			-	-	-
	1000	1580	1370	4564	-	-	-	-	-
	1400	2045	1430	NC	-	-	-	-	-

*rotatable flanges

N C: Consult us

Non-anchored double socket washout tees with flanged branch

■ STANDARD DN 60 to 2000 / ■ EXPRESS DN 60 to 1200

DN body	dn branch	Lu mm	Hu mm	STANDARD				EXPRESS			
				Weight with flange				Weight with flange			
				PN 10 kg	PN 16 kg	PN 25 kg	PN 40 kg	PN 10 kg	PN 16 kg	PN 25 kg	PN 40 kg
250	100*	234	270	43	43	44	44	32	32	33	46
300	100*	237	300	58	58	59	59	40	40	40	60
350	100*	194	330	73	73	73	-	71	71	71	-
400	100*	195	360	84	84	84	-	84	84	84	-
450	100*	315	395	89	89	89	-	119	119	119	-
500	100*	210	420	119	119	119	119	126	126	126	-
600	200*	335	500	192	192	193	195	199	199	200	-
700	250*	365	535	272	271	274	-	272	271	274	-
800	250*	355	585	350	349	352	-	343	343	346	-
900	250*	375	640	474	474	477	-	464	464	467	-
1000	250*	379	705	520	519	522	-	545	453	456	-
1100	250*	822	873	950	950	950	-	NC	NC	NC	-
1200	250*	855	873	951	950	953	-	937	937	NC	-
1400	400*	1010	960	1520	1524	1533	-	-	-	-	-
1500	400*	1110	960	1766	1771	NC	-	-	-	-	-
1600	400*	1050	1100	1977	1980	NC	-	-	-	-	-
1800	400*	1300	1300	2340	2345	NC	-	-	-	-	-
1800	600*	1300	1200	2360	2385	NC	-	-	-	-	-
2000	600*	1115	1310	3236	3261	NC	-	-	-	-	-

*rotatable flanges

STD/EXP - DN 60 to 1200

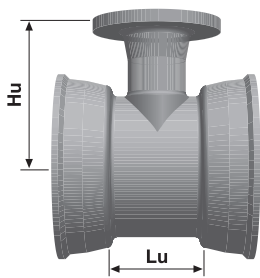

STD - DN 250 to 2000



Particular feature of washout tee: connection geometry between branch and body of flared shape.

Fitting Pressure Classes according to EN 545:2010

DN	Pressure Class
40 to 100	100
125 to 200	64
250 to 350	50
400 to 600	40
700 to 1400	30
1500 to 2000	25

See page 16 for the pressure rating of fittings with STANDARD and EXPRESS joints

Non-anchored double socket tapers

■ **STANDARD DN 80 to 2000**

■ **EXPRESS DN 80 to 1200**

DN	dn	Lu mm	STANDARD	EXPRESS
			Weight kg	Weight kg
80	60	103	6.1	7
100	60	100	6.8	7.7
	80	104	7.5	8.7
125	60	150	8.9	9.5
	80	120	8.9	9.9
150	100	105	9.4	10.4
	60	200	11.2	12.2
	80	170	10.3	12.6
200	100	130	11.1	12.6
	125	107	11.7	13.0
	100	230	17.3	18.3
250	125	180	16.8	18.0
	150	125	16.7	18.0
300	125	275	26.2	30.0
	150	225	26.0	30.0
	200	125	25.3	30.5
350	150	321	36.5	40.0
	200	222	35.9	40.5
	250	123	36.0	35.0
400	200	335	54.5	54
	250	260	52.0	52
	300	187	55.0	53
450	250	335	65.0	65
	300	260	60.0	60
	350	176	62.0	62
500	300	335	77.8	82
	350	234	71.3	76
	400	166	69.2	74
600	350	378	88.6	97
	400	290	86.5	91
	450	160	80.0	78
700	400	460	156.0	137
	450	360	125.0	123
	500	258	120.0	125
800	500	480	198.0	189
	600	267	176.0	166
900	600	467	255	237
	700	280	243	220
1000	700	480	338	304
	800	280	307	265
1100	800	480	417	363
	900	280	378	313
1200	1000	305	N C	419
1400	1000	480	543	517
1500	1200	360	714	-
	1200	410	824	-
1600	1400	100	795	-
	1200	645	1065	-
	1400	350	1009	-
1800	1500	400	1187	-
	1600	427	1267	-
2000	1800	472	1776	-

STD/EXP - DN 80 to 1200

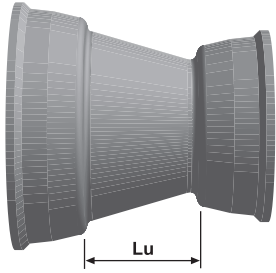

STD - DN 80 to 2000

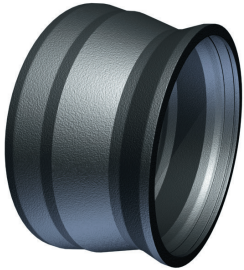

Non-anchored

■ **EXPRESS collars**

DN 60 to 2000

DN	Lu mm	Lt mm	EXPRESS
			Weight kg
60	156	320	6.9
80	158	328	8.8
100	160	334	10.8
125	163	343	13.5
150	165	351	16.7
200	170	368	23.5
250	170	385	37
300	180	400	49
350	185	405	55
400	190	410	67
450	195	391	76
500	200	440	100
600	210	450	131
700	220	500	183
800	230	510	226
900	240	520	274
1000	250	530	325
1100	260	660	500
1200	270	570	470
1400	340	560	1598
1500	Consult us		
1600	360	600	2126
1800	368	640	2755
2000	Consult us		

New
EXPRESS collar DN 1400-2000

EXP - DN 60 to 2000

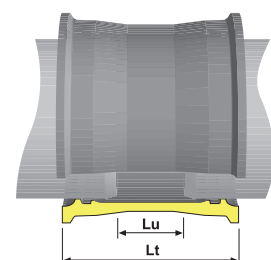

Non-anchored flange-socket ■ STANDARD DN 60 to 2000

DN	Lu mm	Weight with flange / kg			
		PN 10	PN 16	PN 25	PN 40
60*	142	5.9	5.9	5.5	5.5
80*	110	7.2	7.2	7.2	7.2
100*	110	8.7	8.7	9.2	9.2
125*	110	11.0	11.0	11.9	11.9
150*	115	13.8	13.8	14.8	14.8
200*	120	20.4	20.3	23.5	24.1
250*	135	31.3	30.9	33.9	40.9
300*	130	42.0	41.3	44.9	56.7
350*	135	59	59	66	-
400*	140	65	69	78	-
450*	145	82	88	96	-
500*	170	85	98	104	-
600*	170	124	149	152	-
700*	190	158	166	196	-
800*	200	211	220	262	-
900*	210	258	268	319	-
1000*	220	342	359	425	-
1100*	220	350	386	576	-
1200*	240	440	484	565	-
1400*	310	716	768	897	-
1500*	360	898	986	NC	-
1600*	330	963	1046	NC	-
1800*	387	1212	1305	NC	-
2000*	395	1659	1789	NC	-

*rotatable flanges

STD - DN 60 to 2000



Non-anchored flange-socket ■ EXPRESS DN 60 to 1200

DN	Lu mm	Weight with flange / kg			
		PN 10	PN 16	PN 25	PN 40
60*	126	6.0	6.0	6.2	6.2
80*	128	8.2	8.2	8.2	8.2
100*	105	7.2	7.2	5.2	5.2
125*	110	9.2	9.2	10.2	10.2
150*	110	11.3	11.3	12.3	12.3
200*	115	16.3	16.2	17.7	18.0
250*	125	25.4	25.0	28.0	46.0
300*	130	32.5	31.8	35.4	66.0
350*	145	57.6	58.4	64.5	-
400*	150	66.5	70.0	79.0	-
450*	155	82	88	96	-
500*	180	93	106	112	-
600*	190	124	149	152	-
700*	190	159	167	197	-
800*	200	205	213	256	-
900*	210	248	258	309	-
1000*	220	310	327	393	-
1100*	220	363	399	585	-
1200*	240	451	496	576	-

*rotatable flanges

EXP - DN 60 to 1200



Non-anchored flange-spigot

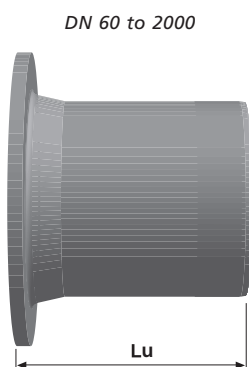

DN	Lu mm	Weight with flange / kg			
		PN 10	PN 16	PN 25	PN 40
60*	350	6	6	5.6	5.6
80*	350	8	8	8	8
100*	350	8.6	8.6	6.5	6.5
125*	350	10.9	10.9	8.6	8.6
150*	400	14.0	14.0	15.0	15.0
200*	400	20.6	20.5	22.0	22.4
250*	400	34	33.5	32	-
300*	450	46.8	46.1	41.6	69
350*	450	58.6	59.4	55.5	-
400*	480	70	74	83	-
450*	500	86	92	100	-
500*	520	104	117	123	-
600*	560	144	169.5	172	-
700	600	189	187	225	-
800	600	239	250	291	-
900	600	287	298	346	-
1000	600	354	376	439	-
1100	600	400	438	513	-
1200	600	469	526	603	-
1400	710	674	726	855	-
1500	750	802	890	NC	-
1600	780	935	1019	NC	-
1800	845	1256	1359	NC	-
2000	885	1643	1749	NC	-

*rotatable flanges
 NC: Consult us
 Suitable for insert, anchored systems (Std Vi, Exp Vi, Std V+i, Uni Vi)

Anchored STANDARD socket pipes

DN	Lu / m		Pipe Ø DE mm	Socket Ø B mm	Average metric Class & weight kg/m			Anchored Joint			
	STANDARD	UNI/PAMLOCK			STANDARD	STANDARD Ve	UNI/PAMLOCK	UNI Vi	UNI Vi*	STD Ve	STD V+i
60	6.00	-	77	144	C40	-	-	STD Vi	UNI Vi*	STD Ve	STD V+i
					9.4	-	-				
80	6.00	6.00	98	167	C40	C100	C100	STD Vi	UNI Vi*	STD Ve	STD V+i
					12.2	15.2	15.8				
100	6.00	5.95	118	188	C40	C100	C100	STD Vi	UNI Vi*	STD Ve	STD V+i
					14.9	18.6	19.6				
125	6.00	5.95	144	215	C40	C64	C64	STD Vi	UNI Vi*	STD Ve	STD V+i
					18.3	22.9	24.3				
150	6.00	6.00	170	242	C40	C64	C64	STD Vi	UNI Vi*	STD Ve	STD V+i
					22.2	27.4	29.0				
200	6.00	5.96	222	295	C40	C64	C64	STD Vi	UNI Vi*	STD Ve	STD V+i
					30.2	38.5	40.1				
250	6.00	5.95	274	352	C40	C50	C50	STD Vi	UNI Vi*	STD Ve	STD V+i
					42.2	47.4	52.3				
300	6.00	5.95	326	409	C40	C40	C50	STD Vi	UNI Vi*	STD Ve	STD V+i
					55.5	55.5	67.4				
350	6.00	5.97	378	464	C30	C30	C40	UNI Ve*	STD Ve	STD V+i	
					68.8	68.8	83.5				
400	6.00	5.97	429	516	C30	C30	C40	UNI Ve*	STD Ve	STD V+i	
					79.4	79.4	98.2				
450	6.00	5.97	480	574	C30	C30	C40	UNI Ve*	STD Ve	STD V+i	
					93.8	93.8	117.3				
500	6.00	5.97	532	629	C30	C30	C40	UNI Ve*	STD Ve	STD V+i	
					111.1	111.1	139.2				
600	6.00	5.97	635	738	C30	C30	C40	UNI Ve*	STD Ve	STD V+i	
					150.6	150.6	187.8				
700	6.00	5.97	738	863	C25	C25	C30	UNI Ve*	STD Ve	STD V+i	
					186.2	186.2	229.1				
800	6.95	6.89	842	974	C25	C25	C30	UNI Ve*	STD Ve	STD V+i	
					229.0	229.0	278.2				
900	6.95	6.87	945	1082	C25	C25	C30	UNI Ve*	STD Ve	STD V+i	
					276.2	276.2	339.5				
1000	6.95	6.88	1048	1191	C25	C25	C30	UNI Ve*	STD Ve	STD V+i	
					330.6	330.6	391.9				
1100	8.19	-	1151	1300	C25	C25	-	UNI Ve*	STD Ve	STD V+i	
					395.4	395.4	-				
1200	8.18	8.15	1255	1412	C25	C25	C30	UNI Ve*	STD Ve	STD V+i	
					461.3	461.3	554.1				
1400	8.17	8.12	1462	1592	C25	-	C25	PAMLOCK	STD Ve	STD V+i	
					634.3	-	689.9				
1500	8.16	8.11	1565	1710	C25	-	C25	PAMLOCK	STD Ve	STD V+i	
					720.3	-	780.6				
1600	8.16	8.11	1668	1816	C25	-	C25	PAMLOCK	STD Ve	STD V+i	
					807.5	-	872.8				
1800	8.15	8.08	1875	2032	C25	-	C25	PAMLOCK	STD Ve	STD V+i	
					995.1	-	1064.7				
2000	8.13	-	2082	2259	C25	-	-	PAMLOCK	STD Ve	STD V+i	
					1210.0	-	Consult us				

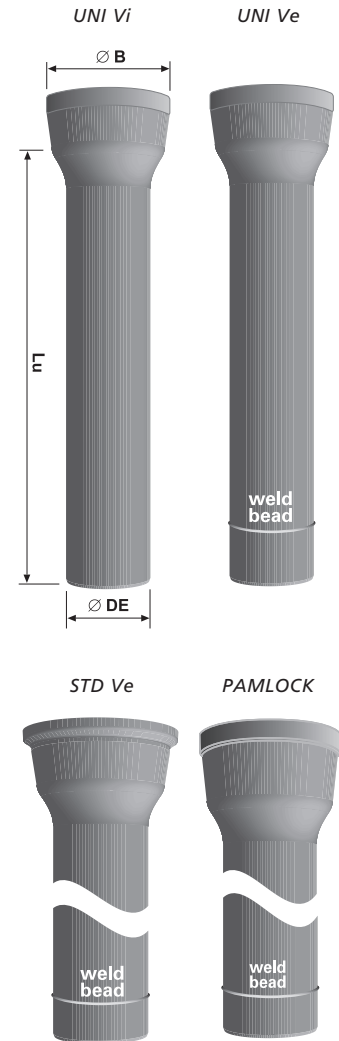

--(1) 5,97m for UNI STD Ve and UNI STD Vi
 *Consult us for UNIVERSAL / PAMLOCK weights

STD Vi



Anchored STANDARD Vi joint assembly Pipes DN 60 to 600			
DN	STANDARD Vi Anchoring gasket Weight kg	DN	STANDARD Vi Anchoring gasket Weight kg
60	0.16	350	1.57
80	0.21	400	1.84
100	0.28	450	2.35
125	0.33	500	2.71
150	0.41	600	3.78
200	0.61	-	-
250	0.86	-	-
300	1.31	-	-

UNI Vi (inserts)



Anchored UNIVERSAL Vi joint assembly Pipes DN 80 to 600			
DN	UNI Vi Anchoring gasket Weight kg	STANDARD Sealing gasket Weight kg	Total accessories Weight kg
80	0.15	0.14	0.29
100	0.20	0.19	0.39
125	0.26	0.24	0.50
150	0.31	0.28	0.59
200	0.49	0.38	0.87
250	0.61	0.49	1.10
300	0.78	0.71	1.49
350	1.47	0.89	2.36
400	1.70	1.07	2.77
450	1.87	1.32	2.19
500	2.54	1.54	4.08
600	3.00	2.16	5.16

UNI Ve (weld bead)



Anchored UNIVERSAL Ve joint assembly Pipes DN 100 to 1200			
DN	UNI Ve Anchoring ring Weight kg	Number of segments	STANDARD Sealing gasket Weight kg
100	0.54	3	0.19
125	0.70	3	0.24
150	0.90	4	0.28
200	1.30	4	0.38
250	1.30	1	0.49
300	1.80	1	0.71
350	2.30	1	0.89
400	3.60	1	1.07
450	4.05	1	1.32
500	4.60	1	1.54
600	8.60	1	2.16
700	9.70	1	2.87
800	17.3	7	3.67
900	22.6	8	4.61
1000	24.8	9	5.58
1200	26.9	10	9.33

STD V+i (inserts + gland)

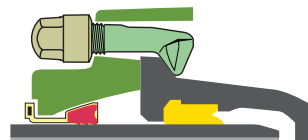

Anchored STANDARD V+i joint assembly Fittings DN 350 to 600						
DN	Gland		Anchoring gasket Weight kg	Ductile iron bolts Nbr	STANDARD sealing gasket Weight kg	Total accessories Weight kg
	Ø ext mm	Weight kg				
350	570	30.5	1.40	8	0.90	39.02
400	618	37.7	1.70	10	1.10	46.60
450	671	43.0	1.80	14	1.32	57.10
500	734	61.7	2.54	16	1.54	74.68
600	840	63.5	3.00	20	2.16	84.46

**Anchored STANDARD Ve joint assembly
Pipes DN 80 to 1200 • Fittings DN 80 to 1200**

DN	Gland		Locking ring	Ductile iron bolts	STANDARD sealing gasket	Total accessories
	Ø ext mm	Weight kg	Weight kg	Nbr	Weight kg	Weight kg
80	233	3.5	0.56	4	0.15	5.76
100	254	4.8	0.49	4	0.20	7.04
125	285	5.9	0.69	6	0.24	11.16
150	310	7.5	0.95	6	0.29	11.06
200	363	9.5	1.5	8	0.38	14.50
250	456	21.0	2.8	6	0.50	29.04
300	516	28.0	3.7	8	0.71	38.73
350	570	30.5	4.5	8	0.90	42.22
400	618	37.7	4.5	10	1.10	51.20
450	671	43	6.0	14	1.32	60.90
500	734	61.7	6.7	16	1.54	82.58
600	840	63.5	9.6	20	2.16	91
700	958	109	14.6	24	2.87	148
800	1100	140	15.7	30	3.67	181
900	1218	184	17.2	30	4.61	228
1000	1306	211	19.3	30	5.59	258
1100	1417	232	17.5	40	7.68	291
1200	1547	222	21.5	40	9.34	287

STD Ve (weld bead + gland)

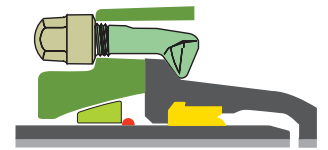

**Anchored PAMLOCK joint assembly
Pipes and fittings DN 1400 to 2000**

DN	Conformator Weight kg	Steel shot Weight kg	Locking ring Weight kg	STANDARD Sealing gasket Weight kg	Total accessories Weight kg
1400	71	15	46	15.5	148
1500	76	15	41	19.8	152
1600	81	15	45	21.0	162
1800	92	15	54	27.7	189
2000	Consult us				

PAMLOCK



STD - DN 60 to 1200

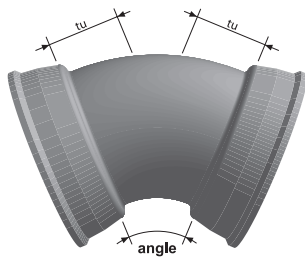

STD Pk - DN 1400 to 2000



Anchored double socket bends

■ STANDARD DN 60 to 2000 / ■ EXPRESS DN 60 to 1200

DN	1/4		1/8		1/16		1/32		Anchored Joint											
	Lu mm	Weight kg	Lu mm	Weight kg	Lu mm	Weight kg	Lu mm	Weight kg												
	STD	EXP	STD	EXP	STD	EXP	STD	EXP	STD	EXP	STD	EXP	STD	EXP						
60	75	75	6.2	6.4	76	76	6.5	6.7	30	30	4.9	5.6	35	35	5.1	5.7				
80	91	91	7.6	8.7	56	56	7	8.1	32	32	6.2	7.4	40	40	6.5	7.6				
100	105	102	10.0	6.8	65	60	8.9	6.0	35	35	7.8	5.4	40	30	7.9	5.3				
125	133	130	13.9	9.0	83	65	12.3	7.6	38	40	9.9	6.8	45	35	10.3	6.6				
150	152	150	18.1	11.5	92	75	15.6	9.5	42	45	12.2	8.4	46	35	12.6	8				
200	200	200	29.2	18.8	100	95	23.7	14.6	51	55	18.9	12.5	52	40	19.2	11.6				
250	252	250	49.6	33.5	139	115	40.5	25.9	70	65	32.2	22	55	50	30.5	20.8				
300	304	280	72.7	43.1	167	150	59	35.6	90	75	42.2	26.8	50	55	39.7	26.6				
350	390	390	115	95	168	168	69	72	78	78	53	57	53	53	49	48.5				
400	436	436	141	140	189	189	89	91	92	92	69	71	58	58	62	64.5				
450	482	482	150	170	216	216	118	120	100	100	88	92	67	67	80	84				
500	525	525	216	215	220	220	146	155	110	110	108	118	71	71	96	106				
600	624	624	311	312	283	283	208	234	140	140	144	166	94	94	128	148				
700	670	-	584	-	335	335	311	312	157	157	231	232	87	87	196	197				
800	735	-	696	-	364	364	414	417	170	170	303	305	90	90	253	255				
900	880	-	800	-	403	403	545	551	197	197	406	406	102	102	326	332				
1000	1000	-	1461	-	440	439	703	649	217	217	507	459	117	117	414	360				
1100	-	-	-	-	540	540	993	993	275	275	650	663	140	140	490	589				
1200	-	-	-	-	537	537	1015	1033	258	258	644	675	138	138	478	509				
1400	-	-	-	-	522	-	1555	-	264	-	1107	-	143	-	884	-				
1500	-	-	-	-	572	-	1815	-	314	-	1367	-	193	-	1143	-				
1600	-	-	-	-	563	-	2089	-	284	-	1479	-	153	-	1173	-				
1800	-	-	-	-	642	-	3126	-	337	-	2070	-	200	-	1542	-				
2000	-	-	-	-	NC	-	NC	-	355	-	2668	-	200	-	2151	-				

N C : Consult us + : Pamlock socket *for UNIVERSAL/PAMLOCK fittings, please consult us for the weight

Anchored double socket tapers

■ STANDARD DN 80 to 2000 / ■ EXPRESS DN 80 to 300

DN	dn	L mm	Weight kg	Anchored Joint			
80	60	103	7	EXP Vi	UNI Ve*	UNI Vi*	STD Ve
100	60	100	7.7				
	80	104	8.7				
125	60	150	9.5	STD Vi	UNI Ve*	UNI Vi*	STD Ve
	80	120	9.9				
	100	105	10.4				
150	60	200	12.2				
	80	170	12.6				
	100	130	12.6				
	125	107	13				
200	100	230	18.3				
	125	180	18				
	150	125	18				
250	125	275	30				
	150	225	30				
	200	125	30.5				
300	150	325	40				
	200	225	40.5				
	250	125	39				
350	200	335	54				
	250	260	52				
	300	190	53				
400	250	340	65				
	300	265	60				
	350	175	62				
450	300	335	82				
	350	240	75				
	400	170	74				
500	350	360	89				
	400	260	86				
	450	160	80				
600	400	460	131				
	450	360	125				
	500	260	120				
700	500	480	210				
	600	280	176				
800	600	480	255				
	700	280	243				
900	700	480	338				
	800	280	307				
1000	800	480	417				
	900	280	378				
1100	1000	N C	N C				
1200	1000	480	543				
1400	1200	345	725				
1500	1200	478	888				
	1400	183	883				
1600	1200	645	1178				
	1400	350	1146				
	1500	483	1132				
1800	1600	428	1640				
2000	N C	N C	N C				

STD - DN 80 to 1200
EXP - DN 80 to 300

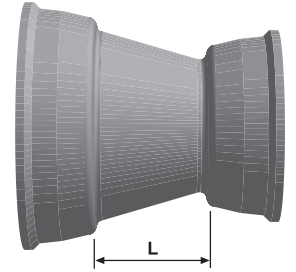

PAMLOCK - DN 1400 to 2000

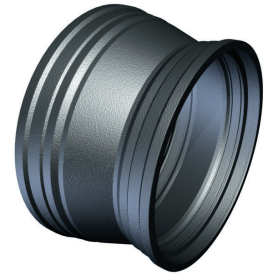

N C : Consult us

*for UNIVERSAL/PAMLOCK fittings, please consult us for the weight

Anchored double socket tees with flanged branch
■ STANDARD DN 60 to 2000 / ■ EXPRESS DN 60 to 1200

DN body	dn branch	Lu mm	Hu mm	STANDARD				EXPRESS				Anchored Joint									
				Weight with flange				Weight with flange													
				PN 10 kg	PN 16 kg	PN 25 kg	PN 40 kg	PN 10 kg	PN 16 kg	PN 25 kg	PN 40 kg										
60	40*	154	141	8.8	8.8	8.8	8.8	9.4	9.4	9.4	9.4	EXP VI	STD VI	UNI Ve	UNI VI°	STD Ve (weld bead and gland)					
	60*	154	161	9.7	9.7	9.3	9.3	10.3	10.3	9.9	9.9										
80	40*	145	149	10.2	10.2	10.2	10.2	11.4	11.4	11.4	11.4										
	60*	145	169	11.1	11.1	10.7	10.7	12.3	12.3	11.9	11.9										
	65*	145	174	11.5	11.5	11.7	NC	12.8	12.8	12.4	12.4										
100	80*	183	165	12.5	12.5	12.5	12.5	13.8	13.8	13.8	13.8										
	40*	150	161	12.0	12.0	12.0	12.0	13.2	13.2	13.2	13.2										
	60*	150	181	12.9	12.9	12.5	12.5	14.1	14.1	13.9	13.9										
	65*	150	186	13.3	13.3	NC	NC	14.6	14.6	14.4	14.4										
125	80*	185	177	14.5	14.5	14.6	14.6	15.8	15.8	15.8	15.8										
	100*	210	180	16.4	16.4	17.0	17.0	17.2	17.2	17.7	17.7										
	40*	150	164	14.3	14.3	14.3	14.3	15.2	15.2	15.2	15.2										
	60*	150	184	15.2	15.2	14.8	14.8	16.1	16.1	15.7	15.7										
	65*	150	189	15.6	15.6	15.8	15.8	16.6	16.6	16.2	16.2										
150	80*	165	195	16.8	16.8	16.8	16.8	17.7	17.7	17.7	17.7										
	100*	190	200	18.5	18.5	19.0	19.0	19.5	19.5	20.0	20.0										
	125*	267	200	23.0	23.0	23.9	23.9	23.0	23.0	23.9	23.9										
	40*	154	176	17.1	17.1	17.1	17.1	18.9	18.9	18.9	18.9										
	60*	154	196	18.0	18.0	17.6	17.6	20.0	20.0	19.6	19.6										
	65*	154	201	18.5	18.5	18.6	18.6	20.5	20.5	20.0	20.0										
200	80*	165	210	19.6	19.6	19.6	19.6	21.5	21.5	21.5	21.5										
	100*	190	215	21.4	21.4	21.9	21.9	24.0	24.0	24.5	24.5										
	125*	220	210	23.8	23.8	24.7	24.7	25.5	25.5	26.4	26.4										
	150*	305	220	29.5	29.5	30.5	30.5	30.5	30.5	31.5	31.5										
	40*	159	209	25.1	25.1	25.1	25.1	25.5	25.5	25.5	25.5										
	60*	159	229	26.0	26.0	25.6	25.6	26.5	26.5	26.1	26.1										
	65*	159	234	26.5	26.5	26.6	26.6	27.0	27.0	26.6	26.6										
	80*	170	240	27.0	27.0	27.0	27.0	28.0	28.0	28.0	28.0										
250	100*	195	245	29.1	29.1	29.6	29.6	30.0	30.0	30.5	30.5										
	125*	220	240	31.6	31.6	32.5	32.5	33.0	33.0	33.9	33.9										
	150*	250	245	34.9	34.9	35.9	35.9	36.0	36.0	37.0	37.0										
	200*	360	260	44.7	44.6	47.0	48.8	45.5	45.4	46.9	46.9										
	60*	164	272	38.9	38.9	38.5	38.5	39.2	39.2	39.2	NC										
	65*	164	272	39.3	39.3	39.4	39.4	39.7	39.8	38.8	NC										
	80*	234	250	43.6	43.6	43.6	43.6	45.1	45.1	45.1	NC										
300	100*	234	270	43.4	43.4	43.9	43.9	32.5	32.5	33.0	46.5										
	150*	251	280	49.5	49.5	50.5	50.5	50.7	50.7	51.7	NC										
	200*	344	290	60.3	60.2	61.4	62.1	62.0	61.9	63.4	NC										
	250*	404	300	69.6	69.2	72.1	NC	72.6	72.2	75.1	NC										
	60*	237	297	56.3	56.3	55.9	55.9	56.8	56.8	56.4	NC										
	65*	237	297	56.7	56.7	NC	NC	57.3	57.3	NC	NC										
300	80*	237	298	57.4	57.4	57.4	57.4	58.3	58.3	58.3	NC										
	100*	237	300	58.1	58.1	58.6	58.6	40.0	40.0	40.5	NC										
	150*	347	310	71.2	71.2	72.2	72.2	72.2	72.2	73.2	NC										
	200*	347	320	75.7	75.4	77.1	77.5	77.0	76.9	78.4	NC										
	250*	467	305	89.4	89.0	91.9	108.7	91.6	91.2	94.5	NC										
300*	467	340	97.9	97.2	100.8	NC	101.0	100.3	103.9	NC											

*rotatable flanges

N C : Consult us

° for UNIVERSAL/PAMLOCK fittings, please consult us for the weight

Anchored double socket tees with flanged branch

STANDARD DN 350 to 2000

DN body	dn branch	Lu mm	Hu mm	Weight with flange			Anchored Joint		
				PN10 kg	PN16 kg	PN40 kg			
350	60*	148	322	63	63	63			
	65*	NC							
	80*	194	310	72	72	72			
	100*	Washout Tee see page 42							
	150*	314	340	87	87	88			
	200*	314	350	91	91	92			
	250*	369	360	104	103	106			
	300*	485	370	120	119	123			
350*	485	380	131	132	138				
400	80*	195	340	80	80	80			
	100*	Washout Tee see page 42							
	150*	315	370	100	100	101			
	200*	315	380	105	105	106			
	250*	429	390	125	125	127			
	300*	429	400	133	134	137			
	400*	545	420	162	166	175			
450	100*	Washout Tee see page 42							
	150*	315	400	122	122	103			
	200*	315	410	115	115	116			
	250*	600	420	129,7	129	132			
	300*	600	430	156,3	156	159			
	400*	600	450	175	188	188			
450*	600	460	172	178	186				
500	100*	Washout Tee see page 42							
	150*	325	430	143	143	144			
	200*	325	440	147	147	148			
	250*	443	450	173	173	175			
	300*	443	460	181	180	184			
	400*	555	480	215	219	228			
500*	675	500	258	271	277				
600	100*	Washout Tee see page 42							
	200*	Washout Tee see page 42							
	300*	452	520	228	228	231			
	400*	570	540	271	275	284			
	600*	800	580	373	398	401			
700	150*	365	520	262	262	263			
	200*	365	525	265	265	266			
	250*	Washout Tee see page 42							
	400*	585	555	347	351	360			
	600*	915	585	474	499	502			
700	915	600	491	499	527				
800	150*	355	580	332	332	333			
	200*	355	585	335	335	336			
	250*	Washout Tee see page 42							
	400*	575	615	430	435	444			
600*	1015	645	617	642	645				
800	1015	675	663	674	715				
900	200*	375	645	420	419	422			
	250*	Washout Tee see page 42							
	400*	595	675	532	536	545			
600*	1145	705	798	823	826				
900	1145	750	867	878	926				

DN body	dn branch	Lu mm	Hu mm	Weight with flange			Anchored Joint		
				PN10 kg	PN16 kg	PN40 kg			
1000	150*	379	705	447	447	447			
	200*	379	705	510	510	512			
	250*	Washout Tee see page 42							
	300*	598	720	570	569	574			
	400*	598	735	639	644	653			
	600*	1258	765	1007	1032	1035			
1000	1258	825	1115	1137	-				
1100	200*	822	883	911	910	-			
	250*	Washout Tee see page 42							
	300*	822	840	910	909	-			
	400*	822	835	999	-	-			
	600*	822	865	907	-	-			
	700	1245	900	NC	-	-			
	800	1245	915	NC	-	-			
	900	1245	930	NC	-	-			
1000	1245	920	NC	-	-				
1100	1245	907	NC	-	-				
1200	200*	855	883	949	949	950			
	250*	Washout Tee see page 42							
	300*	855	840	927	927	931			
	400*	855	835	938	943	-			
	600*	855	865	952	977	980			
	700	1245	900	NC	-	-			
	800	1245	915	1336	1353	-			
	900	1245	930	1378	1397	-			
	1000	1480	920	-	-	1532			
	1100	1480	907	-	2047	-			
1200	1480	950	1587	1732	-				
1400	400*	Washout Tee see page 42							
	600*	1010	980	1542	1567	-			
	800	1950	1040	NC	-	-			
	900	1950	1040	NC	-	-			
	1000	1950	1040	NC	-	-			
	1200	1950	1040	NC	-	2346			
1400	1950	1040	NC	-	-				
1500	400*	Washout Tee see page 42							
	600*	1110	980	1790	1815	-			
	1500	2050	1100	NC	-	-			
1600	300*	1050	1050	1977	1967	-			
	400*	Washout Tee see page 42							
	500*	1050	1075	1989	-	-			
	600*	1050	1090	1997	2022	-			
1000	1505	1150	-	2458	-				
1600	2170	1240	NC	-	-				
1800	200*	1140	258	NC	-	-			
	300*	1155	258	2320	-	-			
	400*	Washout Tee see page 42							
600*	1300	1200	NC	-	-				
800	1360	1230	2704	-	-				
900	1360	1245	NC	-	-				
1800	2485	1380	NC	-	-				
2000	300*	1265	290	3201	3201	-			
	400*	1280	290	NC	-	-			
	500*	1295	290	3221	3235	-			
	600*	Washout Tee see page 42							
	1000	1580	1370	4564	-	-			
	1400	2045	1430	NC	-	-			

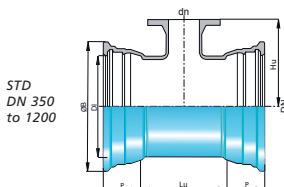

STD Pk
DN 1400
to 2000

*rotatable flanges

for UNIVERSAL/PAMLOCK fittings, please consult us for the weight

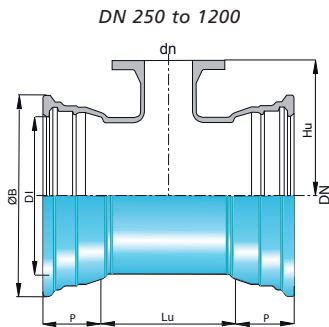

STD Pk - DN 1400 to 2000



Particular feature of washout tee: connection geometry between branch and body of flared shape.

Anchored double socket washout tees with flanged branch
■ STANDARD DN 250 to 2000

DN body	dn branch	LU mm	H mm	Weight with flange				Anchored Joint					
				PN 10 kg	PN 16 kg	PN 25 kg	PN 40 kg						
250	100*	234	270	43	43	44	44						
300	100*	237	300	58	58	59	59						
350	100*	194	330	73	73	73	-						
400	100*	195	360	84	84	84	-						
450	100*	315	395	89	89	89	-						
500	100*	210	420	119	119	119	119						
600	200*	335	500	192	192	193	195						
700	250*	365	535	272	271	274	-						
800	250*	355	585	350	349	352	-						
900	250*	375	640	474	474	477	-						
1000	250*	379	705	520	519	522	-						
1100	250*	822	873	950	950	950	-						
1200	250*	855	873	951	950	953	-						
1400	400*	1010	960	1520	1524	1533	-						
1500	400*	1110	960	1766	1771	NC	-						
1600	400*	1050	1100	1977	1980	NC	-						
1800	400*	1300	1300	2340	2345	NC	-						
1800	600*	1300	1200	2360	2385	NC	-						
2000	600*	1115	1310	3236	3261	NC	-						

*rotatable flanges + : PAMLOCK socket °for UNIVERSAL/PAMLOCK fittings, please consult us for the weight

Anchored flange-socket
EXPRESS DN 60 to 300

DN	Lu mm	Weight with flange				Anchored Joint
		PN 10 kg	PN 16 kg	PN 25 kg	PN 40 kg	
60*	126	6.1	6.1	5.7	5.7	EXP Vi
80*	128	7.9	7.9	7.9	7.9	
100*	130	9.5	9.5	10.0	10.0	
125*	120	11.5	11.5	12.4	12.4	
150*	125	15.1	15.1	16.1	16.1	
200*	130	21.0	21.0	22.5	24.0	
250*	155	26.5	26.5	29.0	46.0	
300*	165	35.5	35.0	38.5	66.0	

EXP - DN 60 to 300

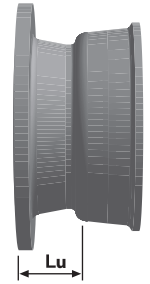

*rotatable flanges

Anchored flange-socket
STANDARD DN 60 to 2000

DN	Lu mm	Weight with flange				Anchored Joint
		PN 10 kg	PN 16 kg	PN 25 kg	PN 40 kg	
60*	142	5.9	5.9	5.5	5.5	STD Vi
80*	110	7.1	7.1	7.1	7.1	
100*	110	8.7	8.7	9.2	9.2	
125*	110	11.0	11.0	11.9	11.9	
150*	115	13.8	13.8	14.8	14.8	
200*	120	20.4	20.3	21.8	22.2	
250*	125	31.3	30.9	33.8	43.2	
300*	130	42.0	41.3	44.9	56.7	
350*	135	59	59	66	-	
400*	140	65	69	78	-	
450*	145	82	88	96	-	
500*	170	85	98	104	-	
600*	180	124	149	152	-	
700*	190	158	166	196	-	
800*	200	211	220	262	-	
900*	210	258	268	319	-	
1000*	220	342	359	425	-	
1100*	230	350	386	572	-	
1200*	225	440	484	565	-	
1400	310	716	768	897	-	
1500	360	898	986	1122	-	
1600	330	963	1046	1194	-	
1800	387	1212	1305	1502	-	
2000	395	1659	1789	2084	-	

STD - DN 1400 to 2000



*rotatable flanges

Anchored flange-spigot with metallic bead

DN 80 to 2000

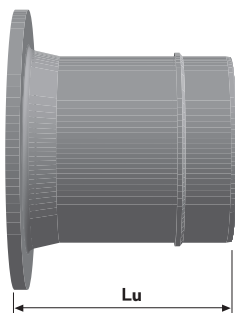

See page 34 for flange Spigot without metallic guide bead

DN	Lu mm	Weight with flange				Anchored Joint			
		PN 10 kg	PN 16 kg	PN 25 kg	PN 40 kg				
80*	350	8.0	8.0	8.0	8.0				
100*	350	9.6	9.6	10.1	10.1				
125*	350	12.5	12.5	13.4	13.4				
150*	400	17.1	17.1	18.1	18.1				
200*	400	24.5	24.0	25.5	27.5				
250*	400	33.0	33.0	35.5	46.0				
300*	450	46	45	49	65				
350*	450	58	58	64	-				
400*	480	70	74	83	-				
450*	500	86	92	100	-				
500*	520	104	117	123	-				
600*	560	144	169	172	-				
700*	600	189	187	225	-				
800*	600	239	250	291	-				
900*	600	287	298	346	-				
1000*	600	354	376	439	-				
1100*	600	400	435	513	-				
1200*	600	469	526	603	-				
1400*	710	674	726	855	-				
1500*	750	802	890	1026	-				
1600*	780	935	1019	1167	-				
1800*	845	1256	1359	1556	-				
2000*	Consult us								

STD Ve (weld bead and gland) or UNIVERSAL Ve

PAMLOCK

*rotatable flanges

Suitable for inserts, not-anchored systems (Std Vi, Exp V+i, Std V+i, Uni Vi)

| PAM commitments |



PAM - Pont-à-Mousson Factory

■ SUSTAINABLE DEVELOPMENT COMMITMENT FROM PAM

PAM is the world leader in water cycle pipeline systems. Whilst this is a cause of great pride for all those that work with and for the company, it is also an immense responsibility.

Sustainable development lies at the heart of its corporate culture. PAM rapidly embraced the pioneering principles of sustainable development formulated by the Brundtland Commission. Since 1987, this international commission has encouraged today's generations to 'meet the needs of the present without compromising the ability of future generations to meet their own needs'.

Its state-of-the-art technologies and focus on research and development have enabled it to consistently provide its customers with quality, sustainable, reliable and ergonomic solutions.

Like communication channels, water and sewerage pipelines are infrastructures created to last for several generations. Sustainable development depends on 'long lasting' rather than 'disposable' installations.

PAM has taken on board these principles and works to provide effective solutions for the environment.

More than 100 capitals and over 1000 large cities worldwide have been equipped with PAM products. Numerous hydraulic, water and sewerage projects are currently run with the support of PAM in order to boost the development of countries mainly in Latin America and Africa, but also in China and the Middle East.

| PAM commitments |

■ PRESSURE CLASSES RANGES

- PAM played a leading role in the development of new pressure classes
- HYDROCLASS, CLASSIC and NATURAL are available in pressure classes
- The whole range of PAM products is available in pressure classes
- HYDROPAM and ALPINAL for higher pressure ranges
- IRRIGAL for irrigation and URBITAL for recycled water



■ MATERIAL IN CONTACT WITH DRINKING WATER

- EN 545 includes reference to the need for compliance with national water quality regulations where they exist:
 - France NF EN 545: ACS
 - United Kingdom BS EN 545: DWI, WRAS
 - Germany DIN EN 545: DVGW GW337 + W270, KTW
- PAM solutions comply with Standards and legislation, among which: France (ACS), United Kingdom (Regulation 31.4 and WRAS), Germany (DVGW) and the Netherlands (KIWA)



| PAM commitments |

■ SUSTAINABLE DEVELOPMENT

- PAM is certified to ISO 14001:2004 by a third party organization
- ZINALIUM external coating triples the lifetime of pipelines in most situations
- In 15 years, PAM has reduced energy requirements by an average of 30% to produce a pipe of the same DN



■ QUALITY MANAGEMENT

- PAM is certified to EN ISO 9001:2008 by accredited third party organization for design, manufacture and marketing of its products
- PAM has its own additional technical specifications, which are even more demanding than those of the EN 545 Standard
- PAM provides a complete, consistent and homogeneous range of pipes, fittings and joints, designed and tested for the highest performances



■ PERFORMANCES

- PAM has the performance of its joints certified by a third party organization
- The angular deflection provided by the flexible joints of PAM products are greater than those specified in the Standard
- PAM joints are certified by tests in COFRAC (ISO/CEI 17 001) accredited laboratories

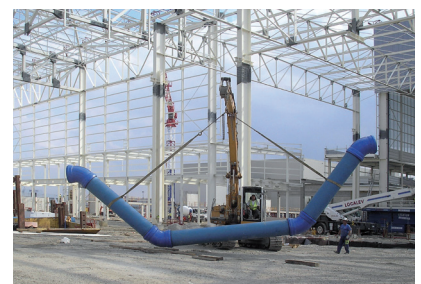

Service, PAM's commitment



Guiding you
with your projects >
***a team of specialists
at your side***



PAM is present
at every step of your project:

- Design
- Implementation
- After-sales

PAM services offers you:

- Support with the preparation of technical files
- Studies adapted to the type of your work sites
- Technical diagnosis and soil surveys
- Technical support on work sites (training when starting work sites, support when carrying out the work)
- After-sales technical support
- Information, recommendations and training for commissioning



PAM customer school >
our skills at your service



Pam provides your employees
with training on the
implementation of its products
for optimum efficiency on site.

- PAM customer school:
Training of installers,
maintenance technicians,
support on site in the fields
of drinking water supply,
sewerage, valves and fittings
and municipal castings in our
internal training centre.

ADVICES FIABILITY ANALYSIS COMMITMENT RESEARCH GROWTH REACTIVITY EXPERTISE ASSISTANCE HUMAN QUALITY SERVICE LOGISTIC PERFORMANCES KNOW-HOW AVAILABILITY LOGISTIC PERFORMANCES GROWTH REACTIVITY RESEARCH QUALITY COMMITMENT INNOVATION

PAM service undertakes to provide you with long-term sustainable technical solutions, permanent innovation and expertise from our specialists.

A sustainable partnership based on trust, PAM is present beside you.



PAM innovation >
benefit from the discoveries made by PAM scientists



Every year, PAM engineer-scientists file more than a hundred patents. They collaborate with numerous universities.

Their expertise in the fields of metallurgy, strength of materials, coatings and the manufacturing processes is at your service to propose all these innovations.

A few recent examples:



NATURAL



Commitment of the sales teams >
guarantee the success of your projects



Every order is followed by a sales assistant who works jointly with the sector manager.

This team is your key partner to guarantee the success of your projects!

They work in close collaboration with:

- our marketing teams,
- our product development teams,
- our plants,

to offer you the best drinking water and sewerage networks.



Reference technical tools >
to help you with decision-making



PAM offers you performant tools to help you make the best possible choices for your networks:

- PAMCAD: network design tools
- Web sites:
 - www.pamline.com
 - www.blutop.fr
- Technical documentation :
 - drinking water supply and sewerage bibles
 - laying recommendations
 - catalogues
 - ductile iron pipelines: compendium
 - multimedia animations

PAM
at your side

Word cloud background containing terms: COMPETENCES, HUMAN QUALITY, SERVICE, LOGISTIC, RESEARCH, KNOW-HOW, PERFORMANCE, SAFETY, EXCELLENCE, COMMITMENT, REALITY, INNOVATION, ANALYSE, ASSISTANCE, REACTIVITY, AVAILABILITY, GROWTH, EXPERTISE, QUALITY, SERVICE, SAFETY, HUMAN QUALITY, COMMITMENT, EXCELLENCE, PERFORMANCE, RESEARCH, KNOW-HOW, LOGISTIC, ASSISTANCE, REACTIVITY, AVAILABILITY, GROWTH, EXPERTISE, QUALITY, SERVICE, SAFETY.

HOW TO CONTACT PAM

AUSTRIA

Saint-Gobain Rigips AUSTRIA GesmbH
Vertriebsbüro PAM
Archenweg 52
6020 Innsbruck
Tel: + 43 512 34 17 17 -0

BELGIUM

Saint-Gobain PAM BELGIUM
Raathshovenstraat, n°2
3400 – LANDEN
Tel: + 32 11 88 01 00

FINLAND

Saint-Gobain PAM FINLAND
Strömberginkuja 2
00380 HELSINKI
Tel: +358 207 424 600

GREECE

Saint-Gobain HELLAS
5 KLEISOURAS STR,
14452 METAMORGOSI ,ATHENS GREECE
Tel: +30 210 2831804

NORWAY

Saint-Gobain BYGGEVARER
Nils Hansens vei 13,
0667 OSLO
Tel: + 47 23 17 58 60

THE NETHERLANDS

Saint-Gobain PAM Netherlands
Markerkant 10-17
1316 AB ALMERE
Tel: + 31 36 53 333 44

POLAND

Saint-Gobain Construction Products POLSKA SP Z O.O.
Ul. Cybernetyki 9
PL - 02-677 WARSZAWA
Tel: + 48 22 751 41 72

PORTUGAL

Saint-Gobain PAM PORTUGAL, S.A.
Rua das Marinhas do Tejo , n° 15
2690-361 SANTA IRIA DE AZÓIA
Tel: + 351 218 925 000

CZECH REPUBLIC

Saint-Gobain PAM CZ
Budova DOCK II,
Smrčková ulice,
Praha 8 – Libeň
Tel: + 420 311 712 611

ROMANIA

Saint-Gobain Construction Products Romania S.r.l.
SGCPro SRL
Soseaua Pipera nr.43, Clădirea Floreasca Park,
corpul A, etajul 3, birourile 25-41, cod 014254,
sector 2, Bucuresti, Romania
Tel: + 40 21 207 57 29

SLOVAKIA

Saint-Gobain Construction Products, s.r.o.
Dlha 1780/6
90031 Stupava
Tel: +421 (0) 2 654 569 61

Enquiries from other EU and overseas countries:
please consult PAM



Saint-Gobain PAM Canalisation •
Head office

21, avenue Camille Cavallier
54705 Pont-à-Mousson Cedex • FRANCE
Phone : +33 (0) 383 807 350
www.pamline.com