

## Kit Accesorio Express PECB + Junta Express Vi

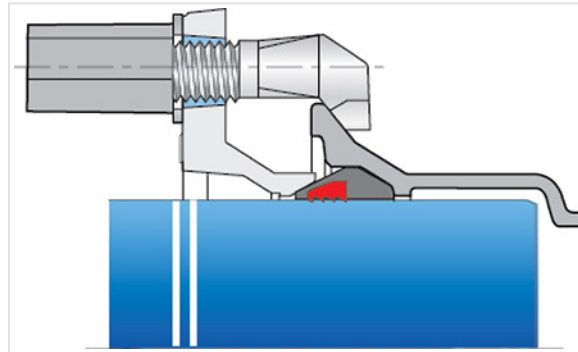

### Manguito con junta Express

DN	Peso total	Referencias
60	11.76 kg	SEA60MN00TT-S07
100	13.9 kg	SEB10MN00TT-S07
125	16.52 kg	SEB12MN00TT-S07
150	19.96 kg	SEB15MN00TT-S07
200	34.94 kg	SEB20MN00TT-S07
250	78.44 kg	SEB25MN00TT-E07
300	103.72 kg	SEB30MN00TT-E07

### Te con junta Express

DN	Ø dn	PN	Peso total	Referencias
250	150	10 16	93.54 kg	SEB25UD1JTT2-E07
300	200	10	132.22 kg	SEB30UD1KTT2-E07

DN mm	PFA bar
60	16
80	16
100	16
125	16
150	16
200	16

DN	PFA
mm	bar
250	16
300	16

\* PFA con tuberías STANDARD C40

## Productos vinculados



Kit Express Vi para Tubería  
y Accesorios Express  
DN300



Kit Express New Vi para  
Tuberías y Accesorios  
Express DN60-250