

Laying instructions - Spare Parts for EURO20 New - Gate Replacement



DN	Mass (kg)	References
40-50	0.80	283112
60-65	1.00	283114
80	1.20	283115
100	1.80	283116
125	2.80	283117
150	3.50	283118
200	8.20	283119
250	12.50	283120
300	23.00	283121

Component



1 x gate

Installation steps

Before proceeding, ensure the installation is no longer under pressure and has been drained.

1. Remove the protective wax from the body/cap connecting screws [2]
2. Unscrew the connecting screws [2]
3. Remove the cap [1] (the entire operating assembly and the gate remain attached to the cap)
4. Unscrew the existing gate to separate it from the screw
5. Remove the operating nut [6] from the gate
6. Fit the operating nut into the new gate
7. Screw the gate assembly back onto the operating screw [12]
8. Retighten the body/cap screws, following the recommended torque values and tightening sequence for the model (see reverse page)



See the video

Tightening of the body/bonnet bolts

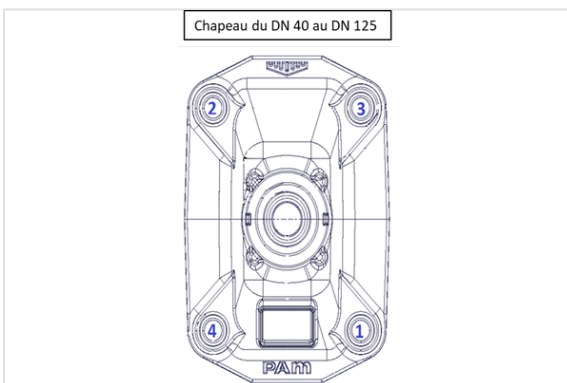

Bonnet DN40 to DN125

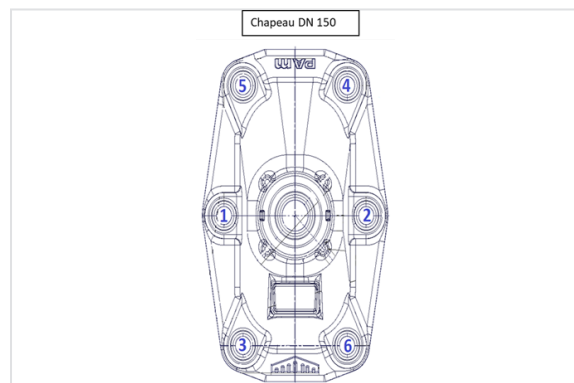

Bonnet DN150



Bonnet DN200-250-300

EURO20 New DN40 à 400 - Couples pour le montage

DN	Versions	Number of screws	Bonnet connecting screws Dimensions	Screws CHc (Nm)**					
				C1	C2	C3	C4	C5	C6
				Screw 1-2	Screw 3-4	Screw 5-6	Screw 7-8	Screw 9-10	Screw 11-12
40	E20 New S15 & S15	4	CHc M8x25	30	30				
50	E20 New S15 & S15	4	CHc M8x25	30	30				
60/65	E20 New S15 & S15	4	CHc M10x25	55	45				
80	E20 New S15 & S15	4	CHc M10x25	55	45				
100	E20 New S15 & S15	4	CHc M12x30	75	65				
125	E20 New S15 & S15	4	CHc M12x30	75	65				
150	E20 New S15 & S15	6	CHc M12x30	75	75	55			
200	E20 New S15 & S15	8	CHc M12x35***	145-150	105-110	70-80	70-80		
250	E20 New S15 & S15	8	CHc M14x40***	165-170	125-130	90-95	90-95		
300	E20 New S15 & S15	8	CHc M16x40***	175-180	165-170	155-160	155-160		

The information on this sketch is, to the best of our knowledge correct at the time of printing. However Saint-Gobain are constantly looking at ways of improving their products and services therefore reserve the right to change without prior notice, any of the data shown. Any orders placed will be subject to our Standard Conditions of Sale, available on request.