

Air Valve Triple Functions TYPE LR with quick anti-fill device

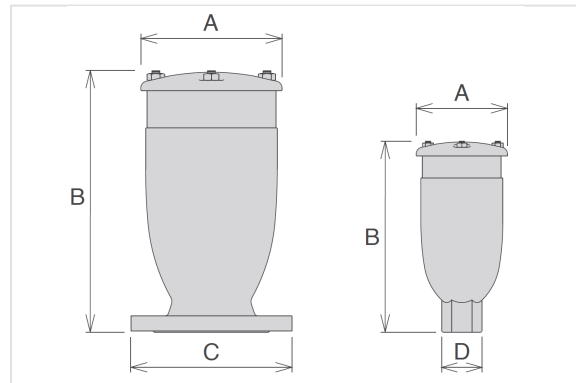

3 FUNCTIONS + QUICK ANTI-FILL AIR VALVE — MODEL LR

The 3-function combined air valve with quick anti-fill device Model LR will ensure the proper operation of the pipeline network by allowing the release of air during working conditions, the evacuation and entrance of large volumes during filling and draining operations, to prevent damage caused by water hammer associated with high air release velocities.

APPLICATION

- Supply, treatment and distribution ductile iron pipes
- Water distribution networks
- Irrigation networks

In general, this model is used at upward slope changes and at high points for overpressure protection.

DN	A (mm)	B (mm)	C (mm)	D (mm)	PN 10		PN 16		PN 25		PN 40	
					Mass (kg)	References	Mass (kg)	References	Mass (kg)	References	Mass (kg)	References
2 "	117	240	-	CH70	5.00	L3RA5110	5.00	L3RA5110	5.00	L3RA5125	5.00	L3RA5140
50 mm	117	250	165	-	7.00	L3RA5010	7.00	L3RA5010	7.00	L3RA5025	7.00	L3RA5040
65 mm	117	250	185	-	7.50	L3RA6510	7.50	L3RA6510	7.50	L3RA6525	7.50	L3RA6540
80 mm	141	305	210-205	-	11.00	L3RA8010	11.00	L3RA8010	11.00	L3RA8025	11.00	L3RA8040
100 mm	172	303	235-220	-	14.00	L3RB1010	14.00	L3RB1010	14.00	L3RB1025	14.00	L3RB1040
150 mm	206	337	305-285	-	23.00	L3RB1510	23.00	L3RB1510	23.00	L3RB1525	23.00	L3RB1540
200 mm	285	515	375-340	-	55.00	L3RB2010	55.00	L3RB2016	55.00	L3RB2025	55.00	L3RB2040
250 mm	380	625	450	-	101.00	L3RB2510	101.00	L3RB2516	101.00	L3RB2525	101.00	L3RB2540

DN	A (mm)	B (mm)	C (mm)	D (mm)	PN 10		PN 16		PN 25		PN 40	
					Mass (kg)	References	Mass (kg)	References	Mass (kg)	References	Mass (kg)	References
300 mm	414	735	485	-	127.00	L3RB3010	127.00	L3RB3016	127.00	L3RB3025	127.00	L3RB3040
350 mm	492	850	580	-	250.00	L3RB3510	250.00	L3RB3516	250.00	L3RB3525	250.00	L3RB3540
400 mm	578	995	660	-	304.00	L3RB4010	304.00	L3RB4016	304.00	L3RB4025		

Operating principle

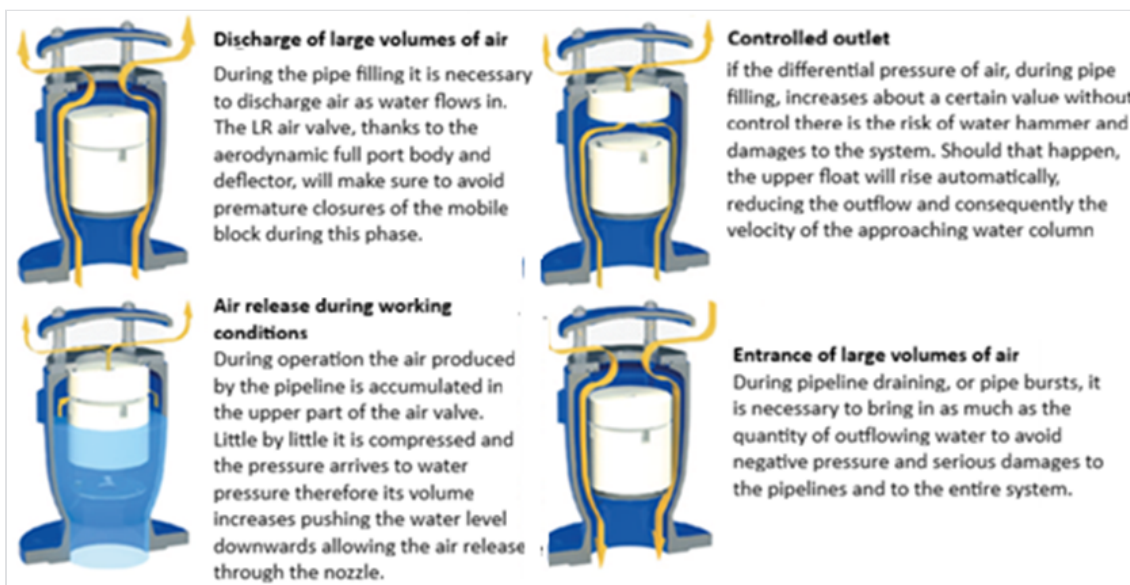

Technical features

- Single chamber body in ductile iron PN40, fitted with ribs for uniform and precise guidance of the moving assembly.
- Blue epoxy coating RAL 5005.
- Drainage valve, for chamber control and pressure relief during maintenance.
- Mobile block composed of a cylindrical float and an upper disk in solid polypropylene, joined together by the stainless steel air exhaust system. The solid cylindrical floats obtained by CNC machining; avoid deformations and ensure great sliding precision inside the body processed ribs and a perfectly vertical thrust.
- Nozzle and seal holder, part of the exhaust system, entirely made of stainless steel AISI 316.
- Maintenance can be performed from the top without removing the air valve from the pipe
- Anti-water hammer system, never in contact with water, achieved by the combination of a stainless steel spring and shaft and a disc with adjustable nozzles to control the air flow.
- Ductile iron cover and stainless steel screen as a standard execution to prevent insect entrance, with other air outlet options available (for submerged applications, air inlet only, air outlet only).

Optional



Breather version

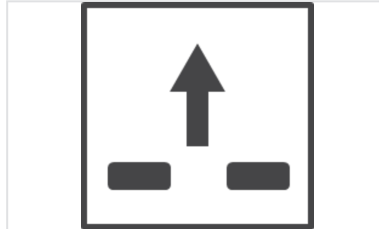

Air outlet only version



Version for Submerged application

1. **The breather version.** allows only for high-flow air intake and air release. This model is recommended for upward slope changes, long ascending sections and wherever degassing is not required.
2. **The air outlet only version.** The air outlet only version allows the air valve to be installed at locations where the piezometric line may drop below the pipe profile and where project requirements dictate that air intake must be avoided.
3. **The version for submerged applications.** allows for operation even in the event of flooding of the chamber. It enables channel jets caused by fast closure of the air valve.

Air flow performances - Aeraulic technical features

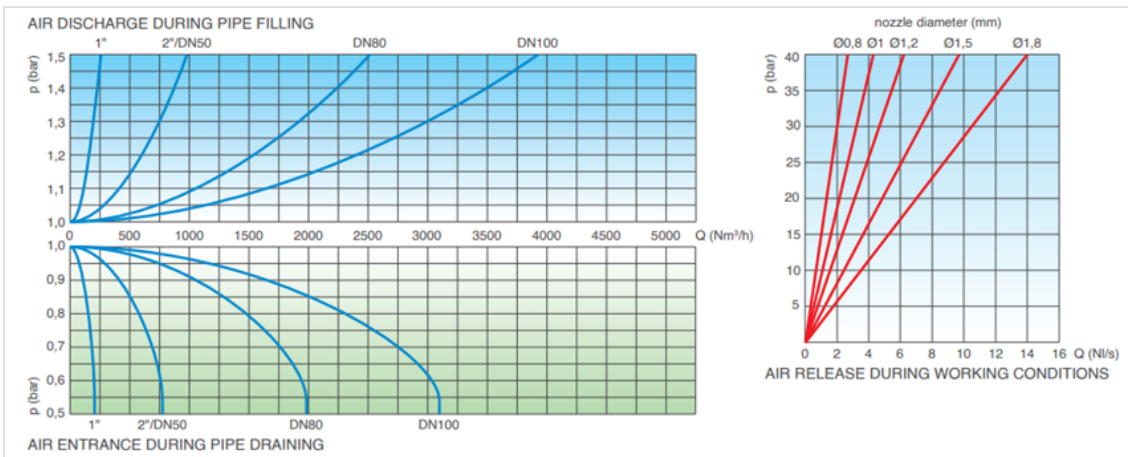

Technical data

Working conditions

- Fluid: treated water. Max. temp.: 60°C.
- Maximum pressure: 40 bar.
- Min. pressure: 0.2 bar, lower on request.

Nozzle

Nozzle diameter according to the size of the air valve and the pressure.

	PN10	PN16	PN25	PN40
2" DN65	1,5	1,2	1	0,8
DN80	1,8	1,5	1,2	1
DN100	1,8	1,5	1,2	1
DN150	3	2,4	1,8	1,2
DN200	4	3	2,4	1,8
DN250	4	4	4	3
DN300	4	4	4	4
DN350	4	4	4	4
DN400	4	4	4	4

Standards

- In compliance with EN-1074/4 and AWWA C-512.
- Flange drilling according to EN 1092/2 or ANSI 150.

Other drillings and coatings on request.

Materials

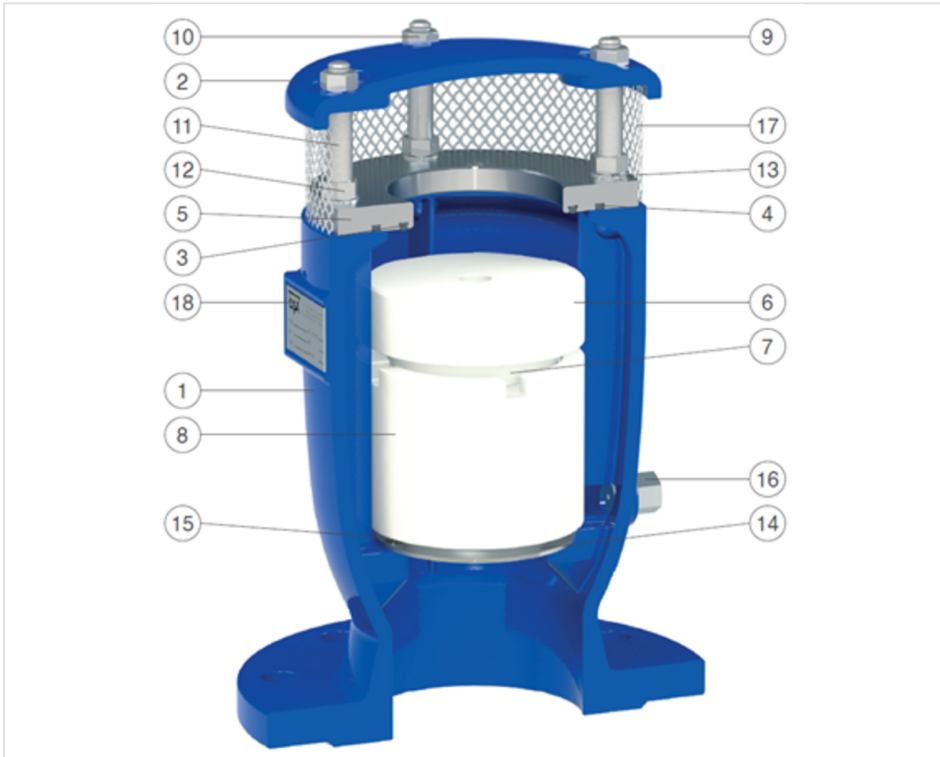

N°	Composant	Matériau Standard	Option
1	Body	Ductile iron GJS 450-10	
2	Cap	Ductile iron GJS 450-10	
3	O-ring	NBR	EPDM/Viton/Silicone
4	O-ring	NBR	EPDM/Viton/Silicone
5	Seat	Polypropylene and NBR	Stainless steel AISI 316
6	RPF plate with O-ring	Polypropylene and stainless steel AISI 316	EPDM/Viton/Silicone
7	Upper plate with nozzle	Polypropylene	
8	Float	Stainless steel AISI 304	
9	Studs	Stainless steel AISI 304	Stainless steel AISI 316
10	Nuts	Stainless steel AISI 304	Stainless steel AISI 316
11	Spacer	Stainless steel AISI 304	Stainless steel AISI 316
12	Nuts	Stainless steel AISI 304	Stainless steel AISI 316
13	Washer	Stainless steel AISI 304	Stainless steel AISI 316
14	Deflector (not in 1")	Stainless steel AISI 304	Stainless steel AISI 316

N°	Composant	Matériau Standard	Option
15	Screw	Stainless steel AISI 304	Stainless steel AISI 316
16	Drain valve	Stainless steel AISI 304	Stainless steel AISI 316
17	Grate	Stainless steel AISI 304	
18	Sticker	Stainless steel AISI 304	

The list of materials and components is subject to change without notice in accordance with technical developments.

The information on this sketch is, to the best of our knowledge correct at the time of printing. However Saint-Gobain are constantly looking at ways of improving their products and services therefore reserve the right to change without prior notice, any of the data shown. Any orders placed will be subject to our Standard Conditions of Sale, available on request.