

## Safety Butterfly Valve Eurostop



The safety butterfly valves are used on hydroelectric plants, aqueducts and waterworks to:

- limit the damages on turbine plant caused by water excess velocity in the pipelines due to any reason;
- shut off the pipelines on pumping plants or penstocks, in case of failure of electric power, to avoid backflow towards the pump.

### Range

The standard version is composed by a butterfly valve with bare shaft and an oleo-dynamic actuator that includes the counterweight and the oleo-dynamic cylinder.

Moreover are available other configuration:

- butterfly with bare shaft with oleo-dynamic actuator and paddle over speed detector with manual resetting pump;
- butterfly with bare shaft with oleo-dynamic actuator and electric resetting unit;
- butterfly with bare shaft with oleo-dynamic actuator and paddle over speed detector and electric resetting unit.

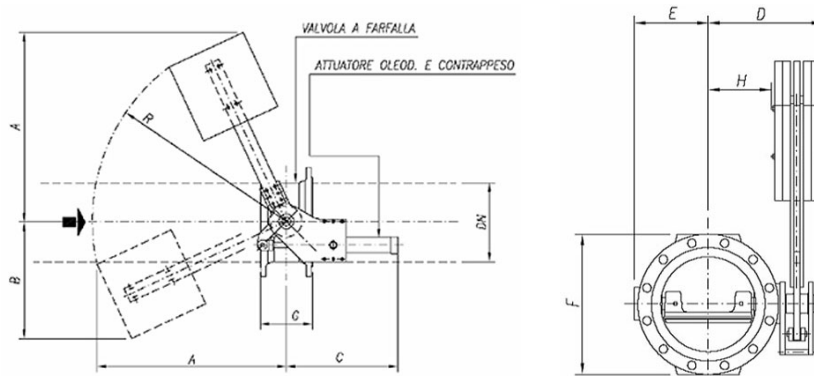

## Material and coatings

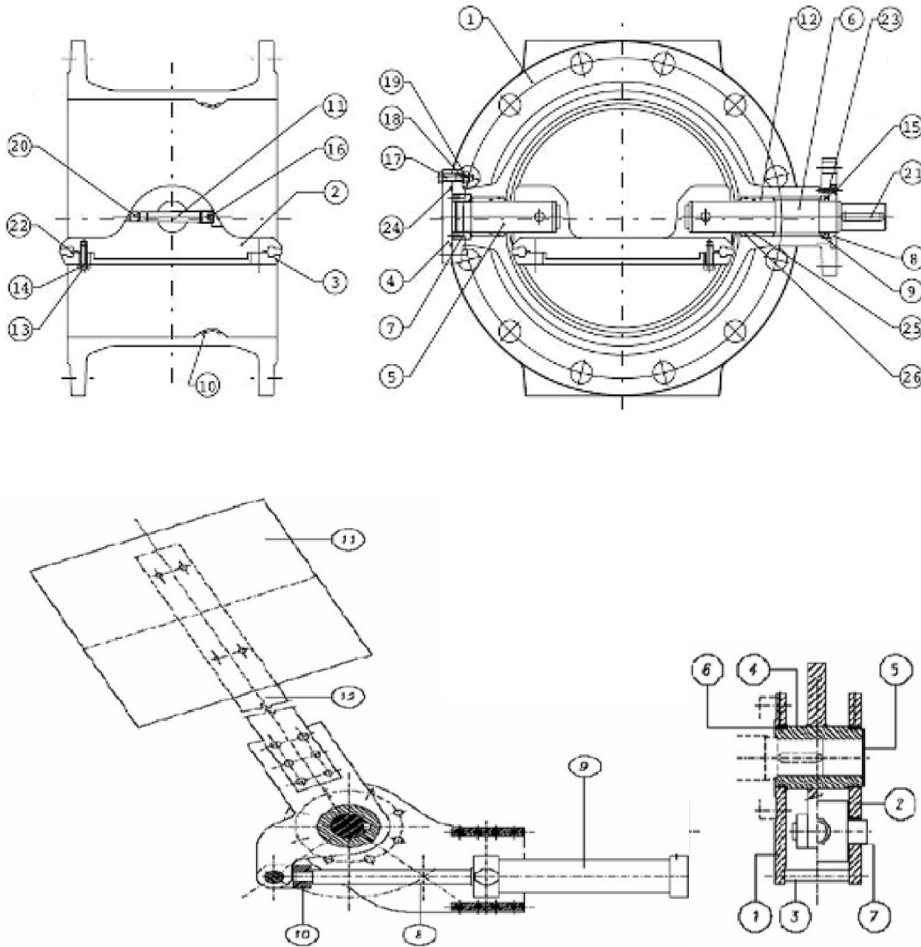

### Butterfly with bare shaft

Item	Description	Material	Coating
1	Body	Ductile iron GS500-7	Epoxy powder minimum thickness 250 micron
2	Disc	Ductile iron GS500-7	Epoxy powder minimum thickness 250 micron
3	Retaining ring	Carbon Steel S235JR	
4	Rear cover	Carbon Steel S235JR	
5	Rear shaft	Stainless steel AISI 420B	
6	Drive shaft	Stainless steel AISI 420B	
7	Lock nut	Bronze 85.5.5.5	

Item	Description	Material	Coating
8	Ring	Bronze 85.5.5.5	
9	Ring	Bronze 85.5.5.5	
10	Seat ring	Stainless steel AISI 316L	
11	Pin	Stainless steel AISI 630	
12	Bearing	Bronze GCuSn12	
13-19	Screws**	Stainless steel A2	
20	Plug*	Brass P-ØST8	
21	Feather key	Steel C40	
22	Gasket	EPDM	
23	Sealing element	PTFE	
24-26	O-ring	EPDM	

(\*) Insert before doing the coating (\*\*) Screws over M18 in steel cl 8.8 Galvanized

### Oleo-dynamic Actuator

The oleo-dynamic actuators are protected with epoxy powder.  
 On the oleo-dynamic actuator are present two limit switchers for the opening/closing position.

## Dimensions and mass - Version with paddle over speed detector and manual resetting pump

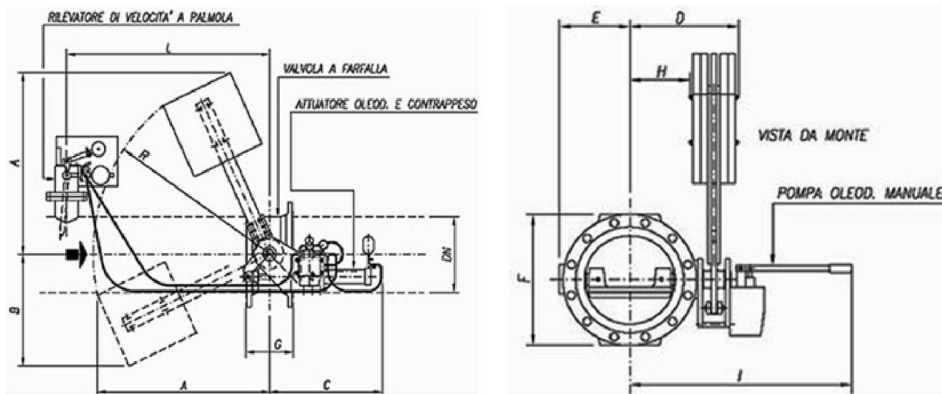

The length "L" is the minimum advised

### Version with paddle over speed detector and manual resetting pump PN10

DN	A	B	K	D	E	F	G	H	R	I	L	Mass
mm	mm	mm	mm	mm	mm	mm	mm	mm	mm	mm	mm	kg
150	653	411	696	352	152	285	210	111	667	948	1200	237
200	653	411	696	382	181	340	230	141	667	978	1200	250
250	653	411	696	441	216	400	250	200	667	1037	1200	273
300	653	411	696	465	240	455	270	224	667	1061	1300	293
350	757	467	783	544	259	505	290	208	777	1079	1300	429
400	757	467	783	595	330	565	310	259	777	1130	1300	463
450	991	604	798	657	354	615	330	316	1020	1201	1300	651
500	991	604	798	682	379	670	350	341	1020	1226	1300	679
600	1272	788	1022	722	433	780	390	446	1304	1343	1400	948
700	1272	788	1022	813	504	895	430	537	1304	1434	1400	1103
800	1520	939	1059	926	596	1015	470	585	1560	1526	1400	1721
900	1520	939	1059	975	642	1115	510	634	1560	1575	1500	1917
1000	1768	1090	1229	1151	712	1230	550	710	1815	1700	1500	3037
1200	1768	1090	1229	1162	850	1455	630	721	1815	1711	1600	3478
1400	1982	1208	1413	1359	962	1675	710	768	2040	1852	1600	5092
1500	1982	1208	1413	1410	1013	1785	750	819	2040	1903	1700	5453
1600	1982	1208	1413	1462	1065	1915	790	871	2040	1955	1700	6050
1800	2196	1326	1079	1796	1250	2115	870	915	2265	2199	1800	9374
2000	2196	1326	1079	1891	1345	2325	950	1110	2265	2294	1800	10779

**Version with paddle over speed detector and manual resetting pump PN16**

DN	A	B	K	D	E	F	G	H	R	I	L	Mass
mm	mm	mm	mm	mm	mm	mm	mm	mm	mm	mm	mm	kg
150	562	368	415	302	152	285	210	142	570	929	1200	171
200	562	368	415	332	181	340	230	172	570	959	1200	184
250	653	411	446	441	216	400	250	200	667	1037	1200	273
300	757	467	533	525	240	455	270	189	777	1060	1300	407
350	757	467	533	564	299	520	290	228	777	1099	1300	449
400	991	604	548	637	334	580	310	296	1020	1181	1300	643
450	991	604	548	657	354	640	330	316	1020	1201	1300	679

DN	A	B	K	D	E	F	G	H	R	I	L	Mass
mm	mm	mm	mm	mm	mm	mm	mm	mm	mm	mm	mm	kg
500	991	604	548	682	379	715	350	341	1020	1226	1300	729
600	1272	788	772	769	460	840	390	493	1304	1390	1400	1073
700	1520	939	809	878	545	910	430	537	1304	1478	1400	1616
800	1768	1090	979	1049	610	1025	470	608	1815	1595	1400	2657
900	1768	1090	979	1100	661	1125	510	659	1815	1649	1500	2828
1000	1768	1090	979	1069	756	1255	550	628	1815	1618	1500	3187
1200	1982	1208	1163	1258	861	1485	630	667	2040	1751	1600	4937
1400	2196	1326	1459	1590	1044	1685	710	709	2265	1993	1600	6583
1500	2196	1326	1459	1641	1095	1820	750	760	2265	2044	1700	7274
1600	2196	1326	1459	1694	1148	1930	790	813	2265	2097	1700	7909
1800	2577	1610	1714	1891	1301	2130	870	980	2639	2289	1800	14615
2000	2577	1610	1714	1986	1396	2345	950	1075	2639	2384	1800	15994

**Version with paddle over speed detector and manual resetting pump PN25**

DN	A	B	K	D	E	F	G	H	R	I	L	Mass
mm	mm	mm	mm	mm	mm	mm	mm	mm	mm	mm	mm	kg
150	562	368	415	309	158	300	210	149	570	936	1200	175
200	653	411	446	418	193	360	230	177	667	1014	1200	265
250	653	467	533	501	216	425	250	165	777	1036	1200	400
300	757	467	533	545	280	485	270	209	777	1080	1300	440
350	991	604	548	606	303	555	290	265	1020	1150	1300	630
400	991	604	548	637	334	620	310	296	1020	1181	1300	679
450	1272	788	772	690	381	670	330	414	1304	1311	1300	944
500	1272	788	772	717	405	730	350	441	1304	1338	1300	991
600	1520	939	809	832	499	845	390	491	1560	1432	1400	1584
700	1768	1090	979	1001	562	960	430	560	1815	1550	1400	2620
800	1768	1090	979	967	654	1085	470	526	1815	1516	1400	2899
900	1982	1208	1163	1111	704	1185	510	520	2040	1604	1500	4257
1000	2196	1208	1163	1164	767	1320	550	573	2040	1657	1500	4701
1200	2196	1326	1459	1489	943	1530	630	608	2265	1892	1600	6391

DN	A	B	K	D	E	F	G	H	R	I	L	Mass
mm	mm	mm	mm	mm	mm	mm	mm	mm	mm	mm	mm	kg
1400	2196	1326	1459	1591	1045	1755	710	710	2265	1994	1600	7600
1500	2577	1610	1714	1736	1146	1865	750	825	2639	2134	1700	13693

### Dimensions and mass - Version with electric resetting unit

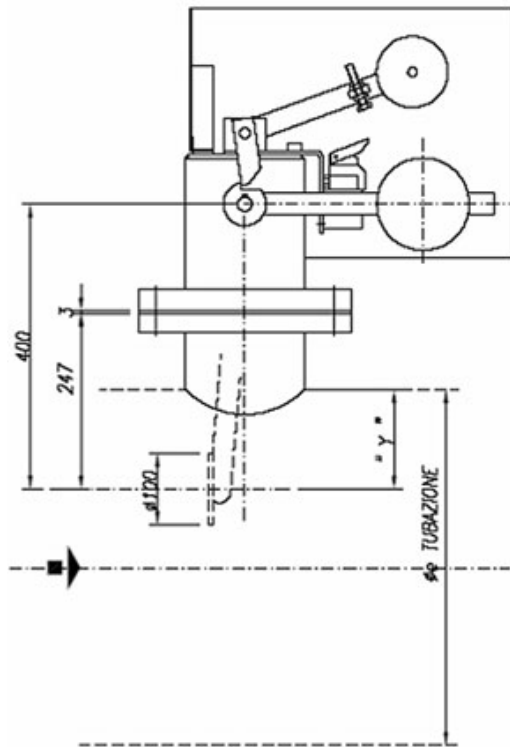

Version for manual resetting pump

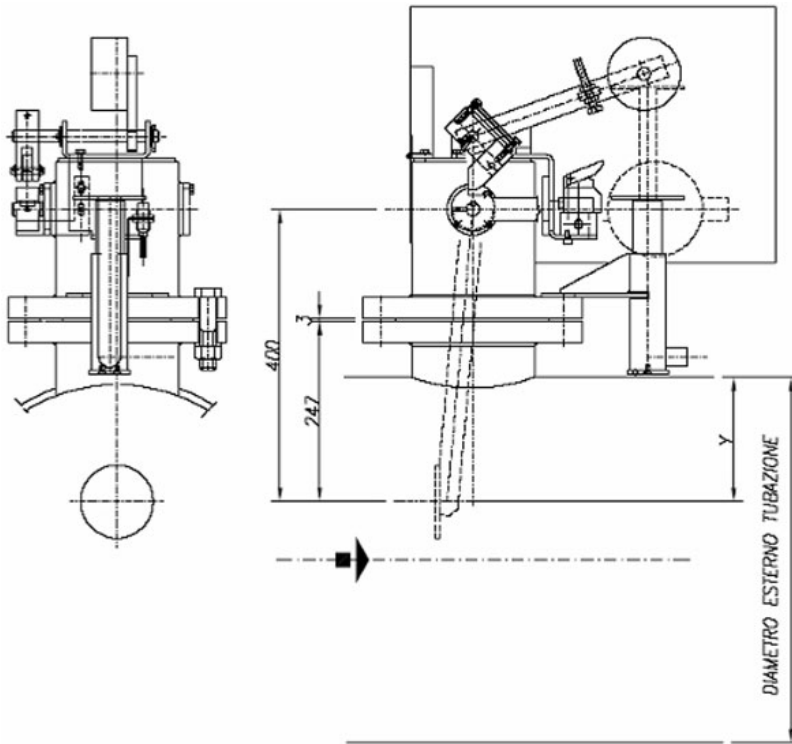

Version for electric resetting pump

For overall dimension see par 2.2.1.

The electric resetting unit is not shown because can be placed by the customer on his requirements.

### Paddle over speed detector

Settable intervention speed from 0,5 to 3 m/s

Y = 170 mm with  $\text{Øe}$  pipe  $\geq 340$  mm

Y =  $\text{Øe}/2$  with  $\text{Øe}$  pipe  $< 340$  mm

Pipe diameter: minimum 168,3 mm ; maximum 2000 mm

Maximum allowable pressure 25 bar

## Applicable Standards

- **Hydraulic test**

Every single butterfly valve is subjected to hydraulic final test with the purpose of verifying the accordance with the prescriptions EN12266 and EN1074:

- Body test at 1,5 time the PFA (open valve);
- Seat test at 1,1 time the PFA (closed valve).

### Product test

Control of coating: test of thickness, holiday test, impact test, MIBK test.

### Conformity to the standards

Product:

- EN 1074-1 and 2

Plant test:

- EN 12266
- EN 1074

Flanges dimension:

- ISO 5752 series 14

Flanges drilling:

- EN 1092-2
- ISO 7005-2

Suitability for potable water:

- Italian DM 174/04
- Conformity to foreign norms: KTW (Germany), WRC (U.K.), ACS (France)

### Marking

On the body like EN19:

- Nominal diameter in mm (DN);
- Nominal pressure in bar (PN);
- Type of ductile iron;
- Manufacturer's logo;
- Model code;
- Fusion date.

On the label like EN19:

- Nominal diameter in mm (DN);
- Nominal pressure in bar (PN);
- Maximum operating pressure (PFA);
- Closing direction;
- Model code;
- Manufacturing order, Order confirmation;
- Manufacturer's logo.

On the disc:

- Nominal diameter in mm (DN);
- Nominal pressure in bar (PN);
- Type of ductile iron;
- Manufacturer's logo;
- Model code.

### Valve selection

To do the right dimensioning of butterfly valve it's necessary to know the hydraulic parameters and also the configuration required:

- Standard version (bare shaft and oleo-dynamic actuator)

- Safety butterfly valve with paddle over speed detector and manual resetting pump (standard version + paddle over speed detector)
- Safety butterfly valve with electric resetting unit:
  - without paddle over speed detector;
  - with paddle over speed detector.

To balance the counterweight is necessary to know:

- Upstream operative pressure (with open valve)
- Intervention speed (standard from 0,5 to 3,0 m/s, for other configuration contact the technical-commercial office)

Outlining what we said:

- Data needed for butterfly valve dimensioning to be given by the customer:

	Upstream Pressure	Maximum speed in pipe	Flow rate Q	Nominal diameter DN
Measure Unit				
Value				

- Data needed for safety system dimensioning to be given by the customer:

	Exercise Upstream Pressure	Intervention paddle speed
Measure Unit		
Value		

## Hydraulic features

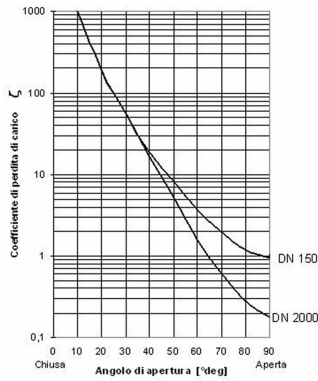

The head loss coefficient can be estimated from this diagram:

VALVOLA A FARFALLA - BUTTERFLY VALVE

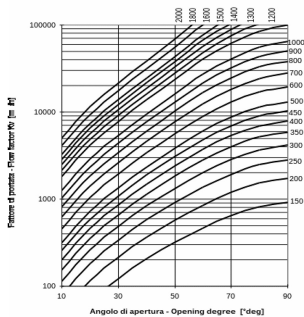

with  $\Delta h$  = head loss [m],  $\zeta$  = head loss coeff,  $v$  = nominal speed [m/s],  $g = 9,81$  [m/s<sup>2</sup>]

Determinates the head loss  $\Delta h$  it's possible to calculate the flow rate  $Q$  in m<sup>3</sup>/h with the following expression (the same expression can be used to, having the project flow rate  $Q$ , to determinate the head loss  $\Delta h$  without using the head loss coefficient):

$$Q = K_v \sqrt{\frac{\Delta h}{10.2}}$$

in which 10,2 is a corrective factor in meters, and  $K_v$  is the flow rate coefficient in m<sup>3</sup>/h, determinable from the following diagram in function of valve open degree: see second diagram

Otherwise it's possible to calculate the head loss with valve completely open, having the project flow rate  $Q$ , in function of DN, using the following diagram: see third diagram

## Instructions for use

### Storage

The butterfly valve will have to be held (if possible) in covered places, the most possible protected from the sun (maximum allowable temperature 70°C in accordance to EN 1074), from the rain and generally from the atmospheric agents. Moreover it will have to be avoided that the seal of the same air valves come to contact with powder or earth

### Installation

The operative instruction for installation changes in order to the required configuration (with or without paddle over speed detector, with manual pump or electric resetting unit).

Before do the installation it is necessary to assure that no earth or powder are inside the valve or in contact with the seat. Do a complete manoeuvre of opening and closing. The installation on water pipe is the one with horizontal axis respect the pipe axis and with safety device on hydraulic right side, for other position contact the technical-commercial office. It's recommended a dismounting joint for valve with DN superior to 150 mm. In any case, for the installation, refer to specific installation and operating manual.

### Maintenance

To guarantee the full efficiency of safety valve, it's necessary to do periodically a maintenance and a simulation of release movement.

We recommend to do this control every six months and, in any case, before the start up of pipeline. In any case, for the maintenance, refer to specific installation and operating manual.

## Linked products

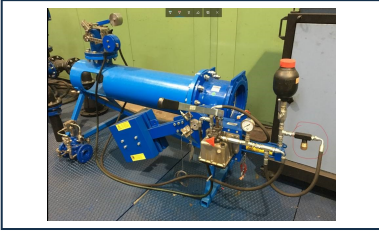

Operation and  
maintenance instructions  
for Eurostop safety  
butterfly valve

*The information on this sketch is, to the best of our knowledge correct at the time of printing. However Saint-Gobain are constantly looking at ways of improving their products and services therefore reserve the right to change without prior notice, any of the data shown. Any orders placed will be subject to our Standard Conditions of Sale, available on request.*