

Alpinal Blank Flange (2" lateral thread) DN400-500

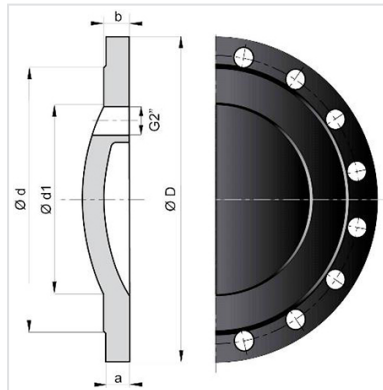

	PN 40		PN 63	
DN	Mass	References	Mass	References
400 mm			165.00 kg	ABB40QL5
500 mm	160.00 kg	ABB50QL4	256.00 kg	ABB50QL5

DN	PN	a	b	Ø d	Ø d1
400 mm	63	65 mm	69 mm	535 mm	385 mm
500 mm	40	52 mm	56 mm	615 mm	485 mm
500 mm	63	75 mm	79 mm	640 mm	485 mm

Field of use:

- For connecting and water supply of snow guns
- Working networks under very high pressures

Main characteristics:

- Internal and external lining : bituminous paint
- Thickness of ductile iron adapted to the pressure
- Elastomer of quality EPDM
- Class : pressure class according to EN 545 and ISO 2531

Linked products



Flanged joint with hot galvanised steel bolts, nuts and washers for ALPINAL

The information on this sketch is, to the best of our knowledge correct at the time of printing. However Saint-Gobain are constantly looking at ways of improving their products and services therefore reserve the right to change without prior notice, any of the data shown. Any orders placed will be subject to our Standard Conditions of Sale, available on request.