

Bend 90° (1/4) PROCESS FM with 2 sockets STANDARD

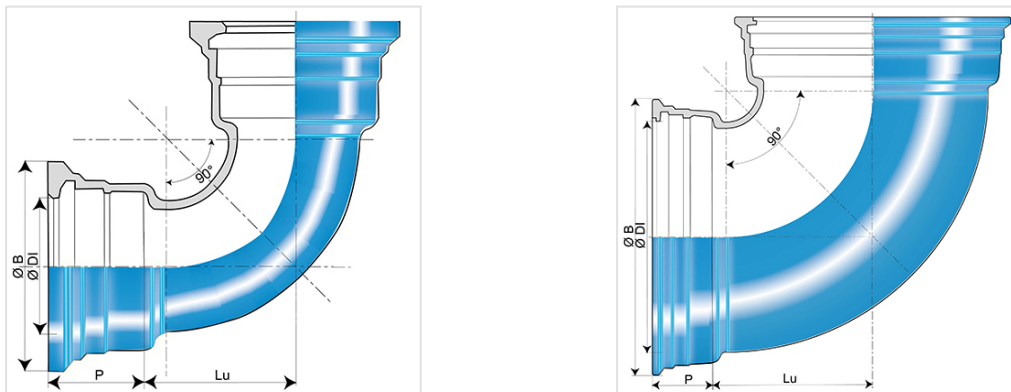

Ductile iron networks for fire protection

Angle	DN (mm)	Lu (mm)	P (mm)	ØDI (mm)	ØB (mm)	Mass (kg)	References
90°	100	105	88	121.4	187.5	10.00	SSB10CA00TTF
90°	150	152.5	94	173.4	241	18.10	SSB15CA00TTF
90°	200	200	100	225.5	294	29.20	SSB20CA00TTF
90°	250	252	105	277.3	351	49.60	SSB25CA00TTF
90°	300	304	110	329.3	408.3	72.70	SSB30CA00TTF
90°	400	436	112	432.4	515.3	141.00	SSB40CA00TTF

Field of use:

- Any fire protection networks, restrained or not, buried
- Installation in any industrial sites or other works of civil engineering

Main characteristics:

- Pressure strength: tests according to FM Approval CN1610 (see label below)
- Internal and external coating: blue Epoxy Powder 250µm (PECB)
- FM Approval (Factory Mutual System)

Marking :

- The indicated values indicate the pressure tests with or without restraining.
- The certification tests FM are realized according to the FM approvals Class number 1610 (September 2006) referential.
- Marking on high durability engraved laser acrylate label.



DN100



DN150

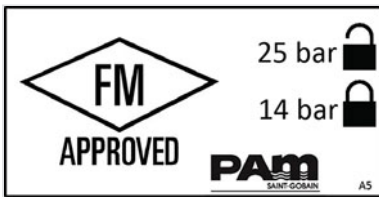

DN200-300



DN400

The information on this sketch is, to the best of our knowledge correct at the time of printing. However Saint-Gobain are constantly looking at ways of improving their products and services therefore reserve the right to change without prior notice, any of the data shown. Any orders placed will be subject to our Standard Conditions of Sale, available on request.