

Butterfly Valve EUROSTOP - Motorizable type



Flanged Butterfly Valve (flange-flange) with joint in the automatic butterfly (JPA) with double eccentricity and long spacing between the flanges.

Ductile iron body and butterfly covered with blue epoxy powder thickness 250 microns mini average according prescriptions of EN 14901-1 (PECB).

Range from DN150 to DN2000mm for pressures of PFA10 to 25 bar.

The EUROSTOP butterfly valve is available in different configuration: manual, buried service, motorized and motorizable (for this three last configuration see the specific TDS).

DN (mm)	Closing direction	PN 10		PN 16		PN 25	
		Mass (kg)	References	Mass (kg)	References	Mass (kg)	References
150	Clockwise	27.66	RPB15NHCH	27.66	RPB15NHCH	39.00	RPB15NHDH
200	Clockwise	47.63	RPB20NHBH	48.00	RPB20NHAH	57.00	RPB20NCDH
250	Clockwise	67.00	RPB25NCBH	68.00	RPB25NCAH	83.00	RPB25NHDH
300	Clockwise	86.00	RPB30NCBH	92.00	RPB30NHAH	114.00	RPB30NCDH
350	Clockwise	111.00	RPB35NHBH	128.00	RPB35NCAH	170.00	RPB35NCDH
400	Clockwise	139.00	RPB40NCBH	145.00	RPB40NCAH	220.00	RPB40NHDH
450	Clockwise	173.00	RPB45NCBH	238.00	RPB45NHAH	289.00	RPB45NCDH
500	Clockwise	215.00	RPB50NCBH	265.00	RPB50NHAH	340.00	RPB50NCDH
600	Clockwise	283.00	RPB60NHBH	372.00	RPB60NCAH	515.00	RPB60NHDH
700	Clockwise	453.00	RPB70NCBH	500.00	RPB70NCAH	975.00	RPB70MHDH

DN (mm)	Closing direction	PN 10		PN 16		PN 25	
		Mass (kg)	References	Mass (kg)	References	Mass (kg)	References
800	Clockwise	582.00	RPB80NHBH	750.00	RPB80MHAH	1243.00	RPB80MHDH
900	Clockwise	778.00	RPB90MHBH	910.00	RPB90MCAH	1693.00	RPB90MHDH
1000	Clockwise	1121.00	RPC10MHBH	1282.00	RPC10MHAH	2091.00	RPC10MQDH
1000						1915.00	RPC10MHDH
1200	Clockwise	1831.00	RPC12MHBH	1975.00	RPC12MHAH	3240.00	RPC12MHDH
1400	Clockwise	2512.00	RPC14MQBH	3419.00	RPC14MHAH	4550.00	RPC14MHDH
1500	Clockwise	2873.00	RPC15MQBH	5282.00	RPC15MHAH	6052.00	203216
1600	Clockwise			4560.00	RPC16MHAH	6200.00	RPC16MHDH
1800	Clockwise	4965.00	165541	6727.00	RPC18MHAH		
2000	Clockwise	6560.00	203241	8038.00	RPC20MHAH		

General dimensions

DN (mm)	PN	G (mm)	H (mm)	I (mm)	J (mm)	K (mm)	L (mm)	M (mm)	D (mm)	R (mm)
150	10 16	210	215	142.9	164	143	50	150	285	100
150	25	210	217	147.9	164	150	50	150	300	100
200	10	230	240	171	164	170	50	180	340	100
200	16	230	240	171.9	164	170	50	180	340	100
200	25	230	272	190.3	164	180	50	180	360	100
250	10	250	292	215.3	164	200	50	230	400	100
250	16	250	292	215.3	164	200	50	230	400	100
250	25	250	297	214.3	201	213	63	230	425	125
300	10	270	319	239.3	164	228	50	250	455	100
300	16	270	321	239.3	201	228	63	250	455	125
300	25	270	321	260.4	201	243	63	250	485	125
350	10	290	340	258.3	201	253	63	260	505	125
350	16	290	340	280.4	201	260	63	260	520	125
350	25	290	376	290.4	206	278	80	310	555	125
400	10	310	371	311.4	201	283	63	310	565	125
400	16	310	407	322.4	206	290	80	310	580	125
400	25	310	425	321.4	337	310	100	310	620	175
450	10	330	427	342.4	206	308	80	340	615	125
450	16	330	445	342.4	337	320	100	340	640	175
450	25	330	471	371.4	337	335	100	340	670	175
500	10	350	452	367.4	206	335	80	320	670	125

DN (mm)	PN	G (mm)	H (mm)	I (mm)	J (mm)	K (mm)	L (mm)	M (mm)	D (mm)	R (mm)
500	16	350	470	367.4	337	358	100	320	715	175
500	25	350	498	398.5	337	365	100	320	730	175
600	10	390	524	421.4	337	390	100	300	780	175
600	16	390	550	451.5	337	420	100	300	840	175
600	25	390	581	474.5	418	423	160	380	845	175
700	10	430	594	495.5	337	448	100	440	895	175
700	16	430	627	521.5	342	455	125	440	910	175
700	25	430	665	552	418	480	160	470	960	175
800	10	470	675	569.5	342	508	125	480	1015	175
800	16	470	713	602	415	513	160	480	1025	175
800	25	470	713	645	548	543	200	480	1085	175
900	10	510	724	623	342	558	125	570	1115	175
900	16	510	764	653	415	563	160	570	1125	175
900	25	510	788	695	548	593	200	570	1185	175
1000	10	550	815	707	480	615	160	620	1230	175
1000	16	550	815	748	545	628	200	620	1255	175
1000	25	550	856	756	595	660	250	620	1320	250
1000	25									
1200	10	630	909	842	548	728	200	750	1455	175
1200	16	630	950	852	622	743	250	750	1485	250
1200	25	630	1024	872	755	765	315	750	1530	250
1400	10	710	1051	953	595	838	250	850	1675	250
1400	16	710	1125	973	755	843	315	850	1685	250
1400	25	710	1126	1016	755	878	315	850	1755	250
1500	10	750	1102	1004	595	893	250	900	1785	250
1500	16	750	1156	1077	755	933	315	900	1865	250
1500	25	750	1186	1078	848	933	400	900	1865	400
1600	16	790	1229	1119	755	965	315	950	1930	250
1600	25	790	1328	1169	848	988	400	950	1975	400
1800	10	870	1331	1179	755	1058	315	1000	2115	250
1800	16	870	1431	1272	848	1065	400	1000	2130	400
2000	10	950	1526	1367	848	1173	400	1050	2345	400
2000	16	950	1526	1367	848	1173	400	1050	2345	400

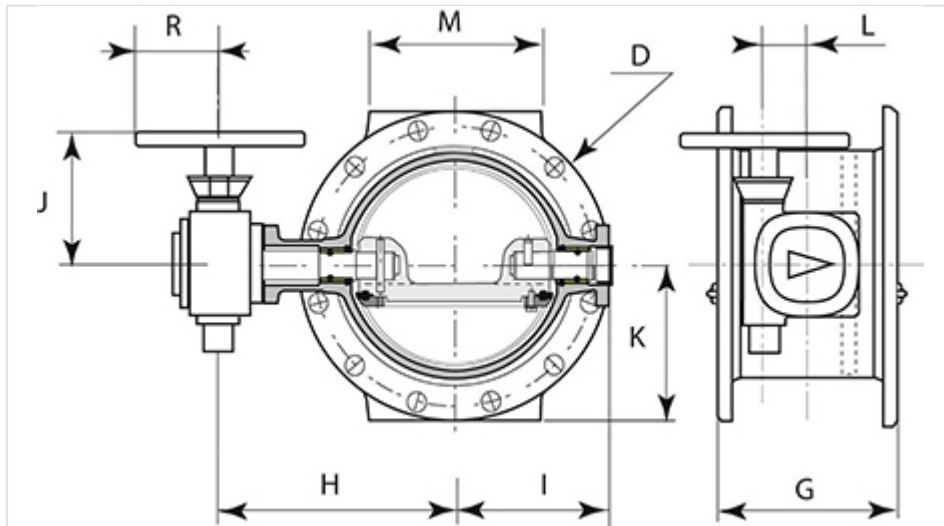

Field of application

Butterfly valves are isolating valves used on water supply networks, in the interconnections of network, in the factories, in pumping stations, on the general networks and on the fire protection networks in the industrial sites.

Butterfly valves are compatible with drinking water and raw water with grid filtration. They will be installed on water networks in factories, in valves chambers or buried.

Their main advantages are:

- Low pressure loss
- Good performance thanks to the choice of the materials, the coatings and the design
- Easy operation per mechanism of the worm type/without end
- Mechanisms equipped with a standardized flange carry-accessory for buried version and motorizable version

Material and coating

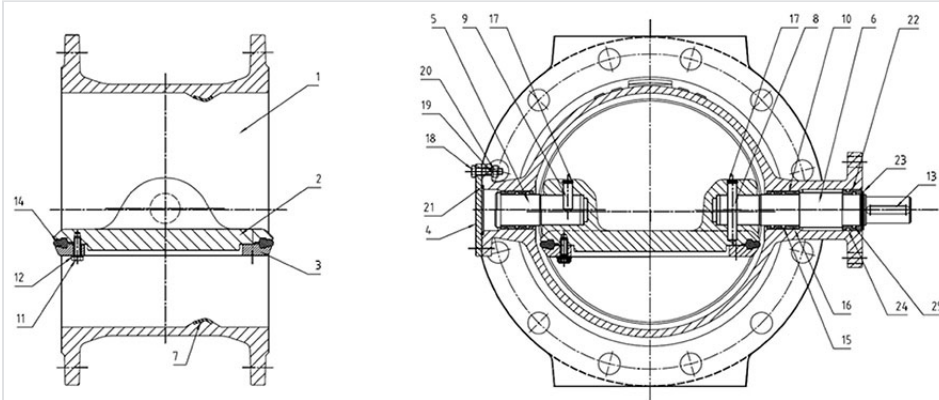

Versions DN150-800 PN10 - DN150-700 PN16 - DN150-600 PN25

Item	Description	Material	Coating
1	Body	Ductile iron GS500-7	Blue epoxy powder thickness 250 microns mini average according prescriptions of EN 14901-1
2	Disc	Ductile iron GS500-7	
3	Retaining ring (*)	Carbon Steel SR235JR	-
4	Cover	Stainless steel X2CrNiMo17-12-2	-
5	Rear shaft	Stainless steel EN 10088 X30Cr13 (420)	-
6	Drive shaft		-
7	Seat ring	Stainless steel EN 10088-2 X2CrNiMo 17,12,2 (316L)	-
8	Cylindrical pin (rear shaft)	Stainless steel EN 10088-3 X5CrNiCuNb 16-4 (630)	-
9	Cylindrical pin (drive shaft)		-
10	Bearing	Bronze EN 1982 CuSn12	-
11	Screw	Stainless steel A2	-
12	Spring washer	Stainless steel A2	-
13	Feather key	Steel C40	-
14	Gasket	EPDM	-
15-16	O-ring	EPDM	-
17	Circular circlips	Stainless steel EN 10088-3 X5CrNi 18-10	-
18	Screw	Stainless steel EN 10088-3 X5CrNi 18-10	-

Item	Description	Material	Coating
19	Spring washer	Stainless steel EN 10088-3 X5CrNi 18-10	-
20	Nut	Stainless steel EN 10088-3 X5CrNiMo 17-12	-
21	O-ring	EPDM	-
22	Bush	POM-C	-
23	External circlip	Stainless steel EN 10088-3 X5CrNi 18-10	-
24-25	O-ring	EPDM	-

(*) DN150-200 : Stainless steel AISI 316L

Material and coating

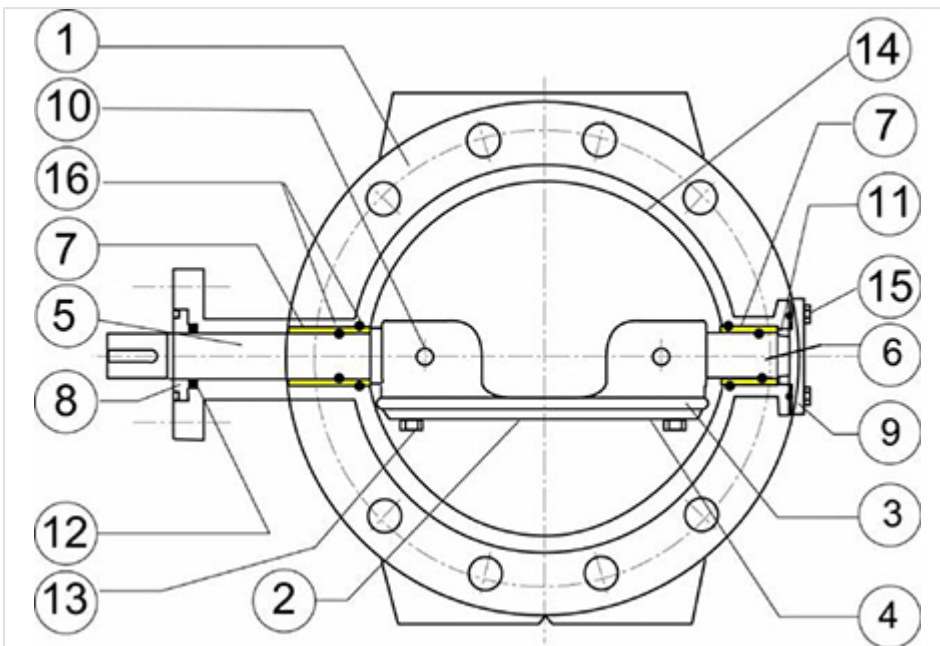

Versions DN900-2000 PN10 - DN800-2000 PN16 - DN700-2000 PN25

Item	Description	Material	Coating
1	Body	Ductile Iron GS500-7	Blue epoxy powder thickness 250 microns mini average according prescriptions of EN 14901-1
2	Disc	Ductile Iron GS500-7	
3	Sealing ring	EPDM	-
4	Retaining ring	Carbon Steel SR235JR	-
5	Shaft	Stainless steel EN 10088 X30Cr13 (420)	-

Item	Description	Material	Coating
6	Spindle	-	
7	Bearings	Bronze EN 1982 CuSn12	-
8	Ring	Gunmetal EN 1982 CuSn5Zn5Pb5	-
9	Rear cover	Carbon Steel SR235JR	Blue epoxy powder thickness 250 microns mini average according prescriptions of EN 14901-1
10	Taper pin	Stainless steel EN 10088-3 X5CrNiCuNb 16-4 (630)	-
11	Lock nut	Gunmetal EN 1982 CuSn5Zn5Pb5	-
12	Sealing element	PTFE	-
13	Internal Screw	Stainless steel type A2	-
14	Body seat ring	Stainless steel EN 10088-2 X2CrNiMo 17,12,2 (316L)	-
15	External Screw	- up to M20: Stainless steel EN 10088-3 - > M20: Steel class 8.8	-
16	O-ring gasket	EPDM	-

Gearbox type and handwheel

Motorizable type PN10

DN mm	Gearbox AUMA type	Handwheel Ø	Number of turns at 90°	Operating torque Nm	Input shaft mm	Flange ISO 5210
		mm				
150	GS 50.3 – F10	200	12,75	8	16	F10
200	GS 50.3 – F10	200	12,75	12	16	F10
250	GS 50.3 – F10	200	12,75	21	16	F10
300	GS 50.3 – F10	200	12,75	30	16	F10
350	GS 63.3 – F12	250	12,75	39	20	F10
400	GS 63.3 – F12	250	12,75	60	20	F10
450	GS 80.3 – F14	250	13,25	70	20	F10
500	GS 80.3 – F14	250	13,25	90	20	F10
600	GS 100.3+VZ4.3 – F16	350	52	35	20	F10
700	GS 100.3+VZ4.3 – F16	350	52	52	20	F10
800	GS 125.3+VZ4.3 – F25	350	52	77	20	F10
900	GS 160.3+GZ160.3 – F25	350	110,5	47	20	F10

DN mm	Gearbox AUMA type	Handwheel Ø mm	Number of turns at 90°	Operating torque Nm	Input shaft mm	Flange ISO 5210
1000	GS 160.3+GZ160.3 - F30	350	110,5	65	20	F10
1200	GS 200.3+GZ200.3 - F30	350	216	60	20	F10
1400	GS 250.3+GZ250.3 - F35	500	212	93	30	F14
1500	GS 250.3+GZ250.3 - F35	500	212	110	30	F14
1600	GS 250.3+GZ250.3 - F35	500	212	130	30	F14
1800	GS 315+GZ30 - F40	500	424	75	20	F10
2000	GS 315+GZ30 - F40	500	424	117	30	F14

Gearbox type and handwheel

Motorizable type PN16

DN mm	Gearbox AUMA type	Handwheel Ø mm	Number of turns at 90°	Operating torque Nm	Input shaft mm	Flange ISO 5210
150	GS 50.3 – F10	200	12,75	8	16	F10
200	GS 50.3 – F10	200	12,75	17	16	F10
250	GS 50.3 – F10	200	12,75	29	16	F10
300	GS 63.3 – F12	250	12,75	42	20	F10
350	GS 63.3 – F12	250	12,75	59	20	F10
400	GS 80.3 – F14	250	13,25	83	20	F10
450	GS 100.3+VZ4.3 – F14	350	52	26	20	F10
500	GS 100.3+VZ4.3 – F14	350	52	33	20	F10
600	GS 100.3+VZ4.3 – F16	350	52	59	20	F10
700	GS 125.3+VZ4.3 – F25	350	52	84	20	F10
800	GS 160.3+GZ160.3 – F30	350	110,5	64	20	F10
900	GS 160.3+GZ160.3 – F30	350	110,5	83	20	F10
1000	GS 200.3+GZ200.3 - F30	350	216	65	20	F10
1200	GS 250.3+GZ250.3 - F35	500	212	104	30	F14
1400	GS 315+GZ30 - F40	500	424	65	20	F10
1500	GS 315+GZ30 - F40	500	424	77	20	F10
1600	GS 315+GZ30 - F40	500	424	94	30	F14
1800	GS 400+GZ35 - F48	800	432	126	30	F14
2000	GS 400+GZ35 - F48	800	432	161	30	F14

Gearbox type and handwheel

Motorizable type PN25

DN	Gearbox AUMA type	Handwheel Ø	Number of turns at 90°	Operating torque	Input shaft	Flange
mm		mm		Nm	mm	ISO 5210
150	GS 50.3 - F10	200	12,75	13	16	F10
200	GS 50.3 - F10	200	12,75	28	16	F10
250	GS 63.3 - F12	250	12,75	45	20	F10
300	GS 63.3 - F12	250	12,75	71	20	F10
350	GS 80.3 - F14	250	13,25	88	20	F10
400	GS 100.3+VZ4.3 - F14	350	52	32	20	F10
450	GS 100.3+VZ4.3 - F16	350	52	43	20	F10
500	GS 100.3+VZ4.3 - F16	350	52	59	20	F10
600	GS 160.3+GZ160.3 - F25	350	110,5	47	20	F10
700	GS 160.3+GZ160.3 - F30	350	110,5	70	20	F10
800	GS 200.3+GZ200.3 - F30	350	216	65	20	F10
900	GS 200.3+GZ200.3 - F35	350	216	84	20	F10
1000	GS 250.3+GZ250.3 - F35	500	212	115	30	F14
1200	GS 315+GZ30 - F40	500	424	74	20	F10
1400	GS 315+GZ30 - F40	500	424	110	30	F14
1500	GS 400+GZ35 - F48	800	432	133	30	F14
1600	GS 400+GZ35 - F48	800	432	153	30	F14

Applicable Standards

Hydraulic test

Every single butterfly valve is subjected to hydraulic final test with the purpose of verifying the accordance with the prescriptions ISO 5208:

- Body test at 1,5 time the PFA (open valve);
- Seat test at 1,1 time the PFA (closed valve).

Product test

- Control of manoeuvre torque (MOT and mST) as defined in the EN1074
- Control of coating: test of thickness, holiday test, impact test, MIBK test

Conformity to the standards

Product:

- EN 1074 – 1 and 2
- EN 593
- ISO 10631

Plant test:

- ISO 5208

Flanges dimension:

- ISO 5752 series 14

Flanges drilling:

- EN 1092-2
- ISO 7005-2

Suitability for potable water:

- Italian CM 102 of 02/12/78
- Conformity to foreign norms: KTW (Germany), WRC (U.K.), ACS (France)

Marking



On the body like EN19:

- Nominal diameter in mm (DN);
- Nominal pressure in bar (PN);
- Type of ductile iron;
- Manufacturer's logo;
- Model code;
- Fusion date.

On the label like EN19:

- Nominal diameter in mm (DN);
- Nominal pressure in bar (PN);
- Maximum operating pressure (PFA);
- Closing direction;
- Model code;
- Manufacturing order, Order confirmation;
- Manufacturer's logo.

On the disc:

- Nominal diameter in mm (DN);
- Nominal pressure in bar (PN);
- Type of ductile iron;
- Manufacturer's logo;
- Model code.

The marking of the valves manufactured by Saint-Gobain refers to the EN 1074-2 and EN 19 international standards.

Markings are either integral markings, cast in the body, or markings made on plates, securely fixed to the body, in accordance with the EN 19 standard specifications.

Specifications EN19		Requirements	Saint-Gobain valves process
Table1-Valve markings			
1	DN	EN 19 § 4.2.1 Mandatory markings Shall be integral markings or on a marking plate	Integral
2	PN		Integral
3	Material		Integral
4	Manufacturer's name or trade mark		Plate
11	Reference to Standard	EN 19 § 4.3 Supplementary markings Items 7 to 21 in Table 1 are optional	Integral
12	Melt identification		Integral
16	Quality test		Printed on body
18	Manufacturing date		Plate
21	Closing direction		Plate + sticker on body

Hydraulic features

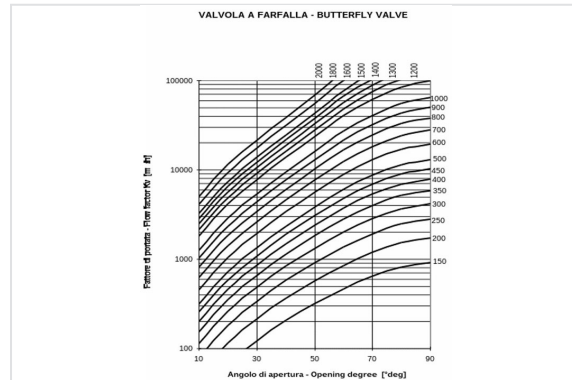
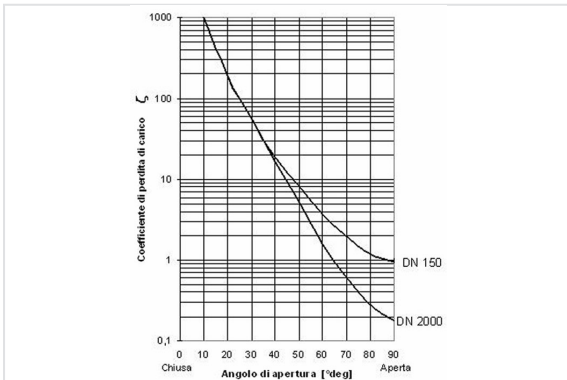

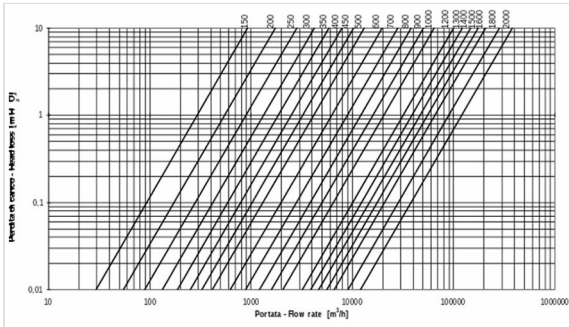

The head loss Δh are variable in function of valve open degree and can be calculated with the following expression:

with Δh = head loss (m), ζ = head loss coefficient (dimensional), v = nominal speed (m/s), $g = 9,81$ (m/s²)

$$\Delta H = \frac{\zeta \cdot v^2}{2 \cdot g}$$

The head loss coefficient can be estimated from the diagram attached.

Determinates the head loss Δh it's possible to calculate the flow rate Q in m³/h with the following expression (the same expression can be used to, having the project flow rate Q , to determinate the head loss Δh without using the head loss coefficient):

$$Q = K_v \sqrt{\frac{\Delta h}{10,2}}$$

in which 10,2 is a corrective factor in meters, and K_v is the flow rate coefficient in m³/h, determinable from the following diagram in function of valve open degree:

Example: Valve DN600 mm - $\Delta h = 3$ m

From the diagram with valve open to 100% the coefficient K_v is 20000 m³/h. Using this date in the flow rate expression:

Otherwise it's possible to calculate the head loss with valve completely open, having the project flow rate Q , in function of DN, using the following diagram:

$$Q = 2000 \times \sqrt{\frac{3}{10,2}} = 10850 \text{ m}^3/\text{h}$$

Cavitation

If the butterfly valve is used only like isolating device there's not cavitation risk.

In the particular case in which it's used like regulating device, this can be possible only respecting the following parameters:

- The valve open degree have to be between 30° and 90° (valve completely open)
- The downstream pressure P2 have to be: $P \geq 0,7 \cdot P - 2,8$ with P upstream pressure.

Instructions for use

Storage

The butterfly valve will have to be held (if possible) in covered places, the most possible protected from the sun (maximum allowable temperature 70°C in accordance to EN 1074), from the rain and generally from the atmospheric agents. Moreover it will have to be avoided that the seal of the same air valves come to contact with powder or earth.

Installation

The butterfly valves are generally installed with retaining ring mounted in the opposite way respect to the direction of flow rate to permit the substitution of gasket without dismounting the valve from pipeline. In any case it is possible to install the butterfly valve with flow rate in opposite direction and also, if required, in vertical position. We recommend to install the butterfly with the operating device on the hydraulic right side of pipeline. It's possible to install the butterfly valve both in chamber valve that underground (choosing the right configuration).

We recommend to insert a dismounting joint for the operation of maintenance.

Maintenance

The butterfly valve does not require a particular maintenance, all parts subjected to wear are perfectly auto-lubricating. In any case, if for a long time will be not used, it is necessary to evaluate the functioning of valve doing (at least one time for year) some manoeuvre of opening-closing.

All the maintenance operation have to be do after the total emptying of pipeline (no flow rate and pressure) to avoid every risk to the people during this operation.

In presence of particularly exercise condition or damage due to external cause, it will be necessary some maintenance operation. In this case the particular shape of EUROSTOP butterfly valve permits the simple gasket substitution without the dismounting of valve from pipeline (if the dismounting joint is present).

Accessories

To adapt the butterfly valves to the different exercise and installation conditions required, they can be equipped with particular accessories used in combination with control devices: please refer to data sheet for accessories.

The technical features in this document are not contractual and can be changed without preliminary notification due to the continuous technical progress of product.

Valve selection

The butterfly valves are generally used as isolating devices type on/off. In some particular case, in which there's low differences of pressure and low flow rate variation can be used like regulating devices, considering the hydraulic parameters necessary to avoid the cavitation risk.

To do the right dimensioning of butterfly valve it's necessary to know the followings parameters:

- Upstream hydrostatic pressure (that is the hydrostatic pressure with valve in closed position)
- The maximum speed in water pipe (generally expressed in l/s) or the nominal diameter and the project flow rate from which it is gained the speed $V=Q/A$

Moreover it's necessary to control that the maximum speed in water pipe have to be equal or inferior to 5m/s, and the exercise temperature have to be between 0°C and 40 °C.

Linked products



Operation and
maintenance instructions
for Eurostop butterfly valve

The information on this sketch is, to the best of our knowledge correct at the time of printing. However Saint-Gobain are constantly looking at ways of improving their products and services therefore reserve the right to change without prior notice, any of the data shown. Any orders placed will be subject to our Standard Conditions of Sale, available on request.