

Cleaning Box (PECR)

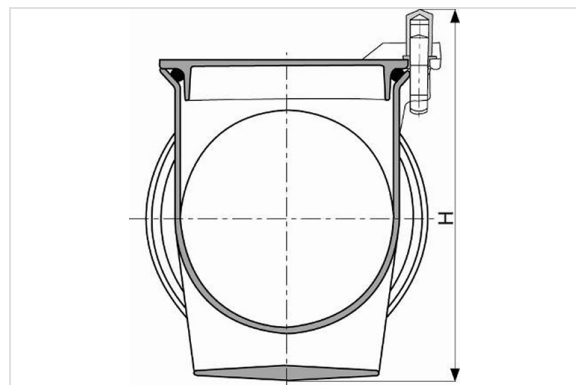

DN (mm)	L (mm)	AxB (mm)	P (mm)	ØDI (mm)	ØDE (mm)	h (mm)	H (mm)	Mass (kg)	References
150	615	400x150	87	175	170	113	272	19.00	TJB15BJ
200	632	400x200	88	225	222	155	339	28.50	TJB20BJ

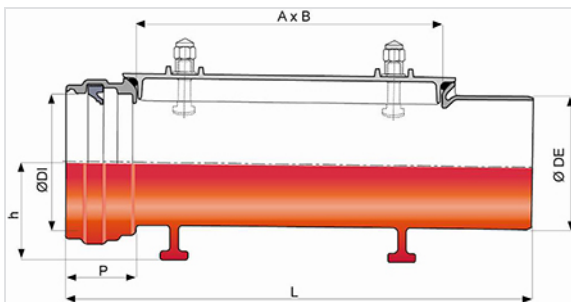

Main characteristics:

- External and internal coating: red epoxy powder 250µm (PECR)
- EN 598 / CE Marking
- Declaration of performances [DoP-INTEGRAL005EN](#)
- Mark NF
- Designed according to the regulatory texts:
 - NF EN 476: general prescriptions for components used in the networks
 - NF EN 752: Conception of sewage projects

- NF EN 1610: Reception of the works
- CCTG: Fascicule 70 (sewage work)

- Perfect leak tightness
- IM joint included (collector)
- 4 bolts and 1 "O" ring NBR (12 mm DN150 – 23 mm DN200) included (cover)
- Dimension of the key for the nuts : 24

Field of use:

- Ductile iron device providing access to the pipe
- Waste water

Linked products



IM Seal for gravity fittings

The information on this sketch is, to the best of our knowledge correct at the time of printing. However Saint-Gobain are constantly looking at ways of improving their products and services therefore reserve the right to change without prior notice, any of the data shown. Any orders placed will be subject to our Standard Conditions of Sale, available on request.