

Collar PUR PUX with 2 sockets EXPRESS

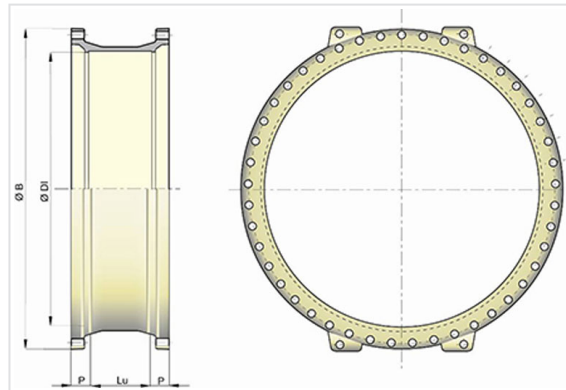

DN (mm)	Lu (mm)	P (mm)	ØDI (mm)	ØB (mm)	Mass (kg)	References
1400	340	110	1470.9	1800	1598.00	218629
1600	360	120	1674.4	1965	2126.00	212963
1800	368	136	1885.1	2240	2755.00	223868
2000	388	146	2092.8	2441	2810.00	237391

Field of use:

- Aggressive or soft waters
- For high corrosive soils, industrial pollution zones

Main characteristics:

- PFA 25
- Sliding collar
- Available only in non-anchored version, assembly with the EXPRESS non-anchored mechanical gasket
- Internal-external coating: polyurethane coating in compliance with Standard EN 15655
- In compliance with EN 545:2010 and ISO 2531:2009

DN1400 This reference includes 1 collar plus :

- 2 GLANDS DN1400 PZN VBI 100µm
- 60 BOLTS M39x180 GALVANISED STEEL (70µm)
- 120 WASHERS M39 GALVANISED STEEL (70µm)
- 2 EPDM GASKETS DN1400 for water
- MECHANICAL LUBRICATING PASTE BOX

DN1600 This reference includes 1 collar plus :

- 2 GLANDS DN1600 PZN VBI 100µm
- 90 BOLTS M39X220 GALVANISED STEEL (70µm)
- 180 WASHERS M39 GALVANISED STEEL (70µm)
- 2 EPDM GASKETS DN1600 for water
- MECHANICAL LUBRICATING PASTE BOX

DN1800 This reference includes 1 collar plus :

- 2 GLANDS DN1800 PZN VBI 100µm
- 80 BOLTS M39x220 GALVANISED STEEL (70µm)
- 160 WASHERS M39 GALVANISED STEEL (70µm)
- 2 EPDM GASKETS DN1800 for water
- MECHANICAL LUBRICATING PASTE BOX

DN2000 This reference includes 1 collar plus :

- 2 GLANDS DN2000 PZN VBI 100µm
- 84 BOLTS M39x220 GALVANISED STEEL (70µm)
- 168 WASHERS M39 GALVANISED STEEL (70µm)
- 2 EPDM GASKETS DN2000 for water
- MECHANICAL LUBRICATING PASTE BOX

The information on this sketch is, to the best of our knowledge correct at the time of printing. However Saint-Gobain are constantly looking at ways of improving their products and services therefore reserve the right to change without prior notice, any of the data shown. Any orders placed will be subject to our Standard Conditions of Sale, available on request.