

Cross (PECB) with Fixed Flanges

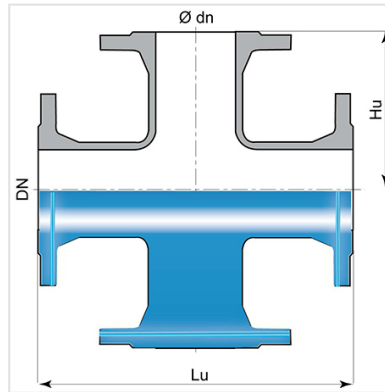

DN (mm)	Ødn (mm)	Lu (mm)	Hu (mm)	PN 10		PN 16		PN 25		PN 40	
				Mass (kg)	References	Mass (kg)	References	Mass (kg)	References	Mass (kg)	References
80	80	330	165	22.00	BBA80XN1ETT	22.00	BBA80XN1ETT	22.00	BBA80XN1ETT		
100	100	360	180	25.00	BBB10XN1FTT	25.00	BBB10XN1FTT				
150	100	440	210	38.00	BBB15XN1FTT	38.00	BBB15XN1FTT	47.00	BBB15XN3FTT	47.00	BBB15XN3FTT
150	150	440	220	45.00	BBB15XN1JTT	45.00	BBB15XN1JTT				
200	100	520	240	54.00	BBB20XN1FTT	48.00	BBB20XN2FTT				
200	200	520	260	60.00	BBB20XN1KTT	67.00	BBB20XN2KTT				
200	150	520	250			61.00	BBB20XN2JTT				
250	250	700	350			104.00	BBB25XN2LTT				
300	300	800	400	145.00	BBB30XN1MTT	203.00	BBB30XN2MTT				
400	400	900	450	214.00	BBB40XN1NTT	234.00	BBB40XN2NTT				
500	500	1000	500			469.00	BBB50XN2QTT				
600	600	1100	550	424.00	BBB60XN1RTT	604.00	BBB60XN2RTT	629.00	BBB60XN3RTT		

Field of use:

- For drinking water networks

Main characteristics:

- External and internal coating : Blue epoxy powder 250 microns average thickness with a minimum of 200 microns, conforming to EN 14901 (PECB)
- In conformity with EN 545:2010 and ISO 2531:2009

Linked products

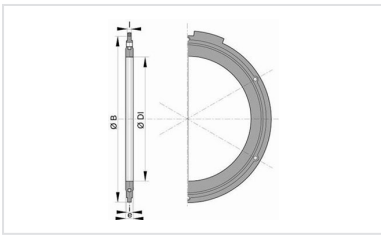

Flanged joint with hot galvanized steel bolts, nuts and washers

The information on this sketch is, to the best of our knowledge correct at the time of printing. However Saint-Gobain are constantly looking at ways of improving their products and services therefore reserve the right to change without prior notice, any of the data shown. Any orders placed will be subject to our Standard Conditions of Sale, available on request.