

Ductile iron Round Saddle 90° for Concrete + Joint IM gasket



Linking gasket to the concrete (type TRELLEBORG): for DN150 reference SAP 144171 - for DN200 reference SAP 158311

DN connector	DN saddle branch	ØB (mm)	ØDI (mm)	D (mm)	Mass (kg)	References
(*) ≥ 60 mm	150 mm	212	173.2	175	6.50	TJB15FR
(*) ≥ 60 mm	200 mm	266	225.2	228	9.40	TJB20FR

* Wall Thickness

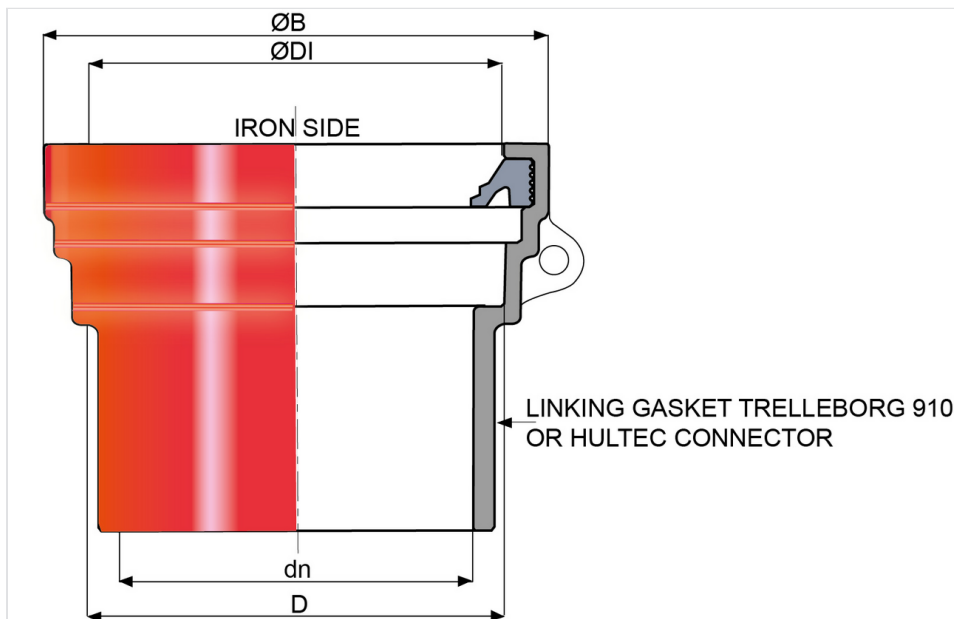

Field of use:

- Separate sewer system and combined sewer system
- Application: gravity flow
- Type of effluent: domestic wastewater and rainwater
- Lastingly leak tight and impermeable
- For effluents between pH1 and pH13

Main characteristics:

- External and internal coating: red epoxy powder 250µm (PECR)
- EN 598 / CE Marking
- Declaration of performances [DoP-INTEGRAL005EN](#)
- Mark NF
- Designed according to the regulatory texts:
 - NF EN 476: general prescriptions for components used in the networks
 - NF EN 752: Conception of sewage projects
 - NF EN 1610: Reception of the works
 - CCTG: Fascicule 70 (sewage work)

Material and coating:

Designation	Material	Coating
Body	Ductile Iron	Red-brown Epoxy powder
IM Gasket	Nitrile	

The information on this sketch is, to the best of our knowledge correct at the time of printing. However Saint-Gobain are constantly looking at ways of improving their products and services therefore reserve the right to change without prior notice, any of the data shown. Any orders placed will be subject to our Standard Conditions of Sale, available on request.