

Express New Bolt

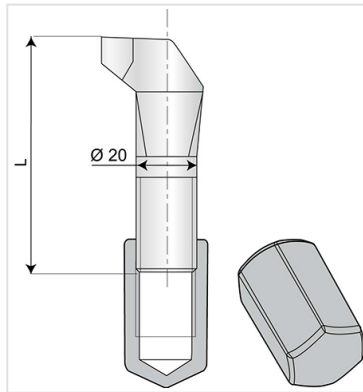

Ø (mm)	L (mm)	Mass (kg)	References
20	77	0.34	JXM20NN77D
20	110	0.56	JXM20NN110

Field of use:

- For drinking water networks

Main characteristics:

- Iron bolts (Galvanization + parkerization + black cataphoresis)
- EN 545

The information on this sketch is, to the best of our knowledge correct at the time of printing. However Saint-Gobain are constantly looking at ways of improving their products and services therefore reserve the right to change without prior notice, any of the data shown. Any orders placed will be subject to our Standard Conditions of Sale, available on request.