

Express New Vi Kit for Express Pipes and Fittings DN60-250



The Express New Vi Joint is a mechanical joint. The watertightness is made by the axial compression of an elastomer gasket (with inserts) thanks to a gland tightened with iron bolts and steel washers.

DN	Angular deflection	PFA	Mass	References
60 mm	5 °	16 bar	2.43 kg	JWA60LNN2
80 mm	5 °	16 bar	2.93 kg	JWA80LNN2
100 mm	5 °	16 bar	3.40 kg	JWB10LNN2
125 mm	5 °	16 bar	3.91 kg	JWB12LNN2
150 mm	5 °	16 bar	4.78 kg	JWB15LNN2
200 mm	3 °	16 bar	10.22 kg	JWB20LNN2
250 mm	3 °	16 bar	14.15 kg	JWB25LNN2

For all DN: kit components cannot be purchased separately

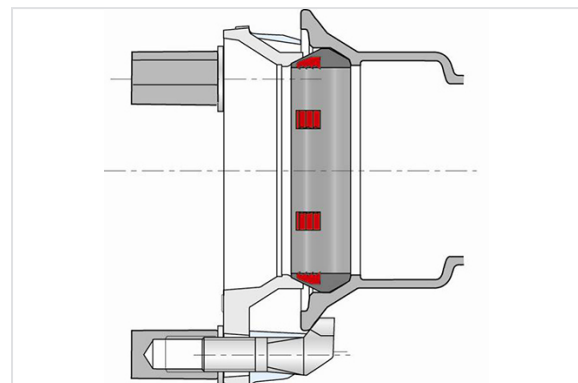
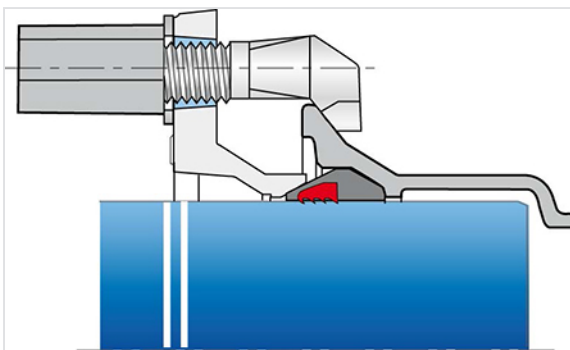

Field of use:

- For drinking water networks

Main characteristics:

- Elastomer quality: EPDM (EN 681-1)
- Coating of the gland: Aquacoat fittings
- Corrosion resistant iron bolts conforming to ISO 9 227
- Steel washers M20: DN60-125 galvanized steel - DN200 red galvanized steel
- Kit complies with standard EN 545:2010 and ISO 2531:2009

Accessories

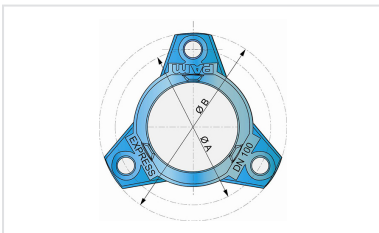

Express New Gland
DN60-250

Linked products

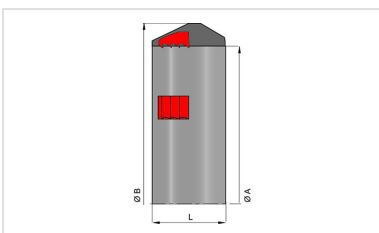

Express New Vi Gasket
DN60-250

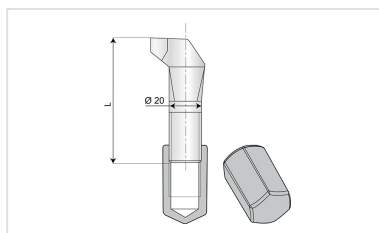

Express New Bolt

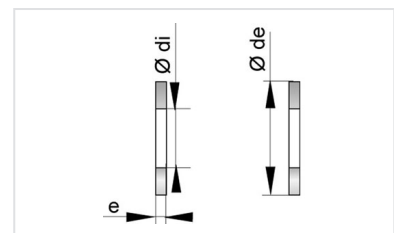

Washers M20 Zinc Coated

The information on this sketch is, to the best of our knowledge correct at the time of printing. However Saint-Gobain are constantly looking at ways of improving their products and services therefore reserve the right to change without prior notice, any of the data shown. Any orders placed will be subject to our Standard Conditions of Sale, available on request.