



## Concave grating AQUAVANTAGE Square frame D400 class



AxB (mm)	CxD (mm)	F (mm)	H (mm)	h (mm)	Total Mass (kg)	Waterway area	Packaging	References
738x742	600x600 (*)	486	150	53.7	83.20	22.0 dm <sup>2</sup>	5	242564
1050x1020	900x900 (*)	697	180	80.5	183.60	52.5 dm <sup>2</sup>	5	256281
830x1355	675x1200 (*)	925	150	60.4	188.00	48.8 dm <sup>2</sup>	5	256280
1356x809	1200x675	1020	200	106.8	178.80	51.1 dm <sup>2</sup>	5	251829

(\*) removable grate version

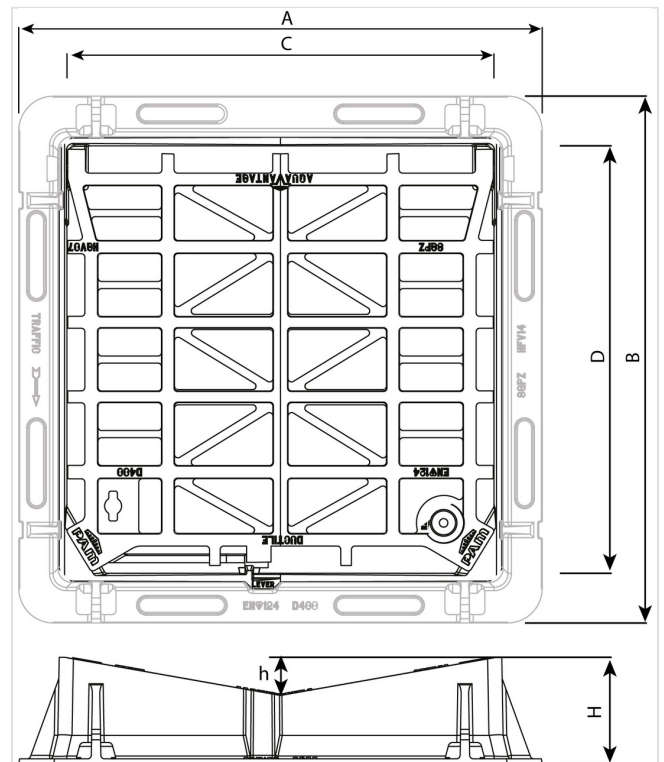
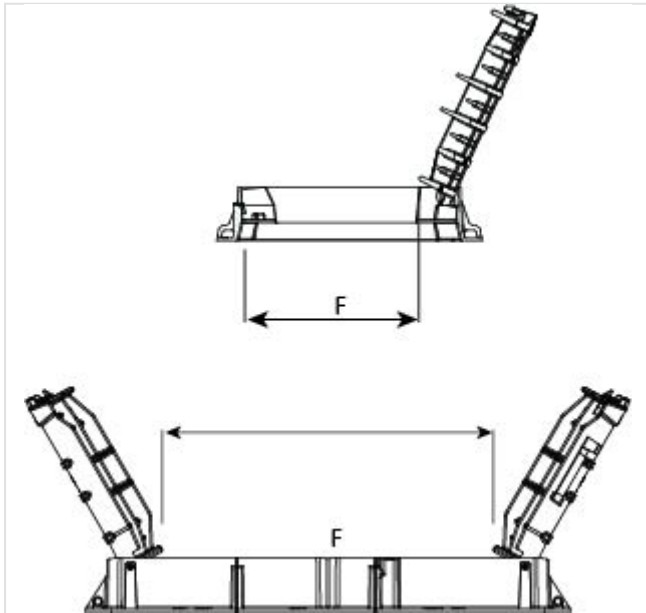

### Material and coating:

- Frame and grating in Ductile Iron EN GJS 400-15: water base

### Field of application:

- D400 class (Group 4) according to standard EN124
- Channelled drainage

### Main characteristics:

- Captive hinged grating
- Non-rock design
- Single-piece grating
- Automatic grating security locking
- Wedge seating
- HA 102 and 104/09 compliant
- High absorption capacity



## Water course

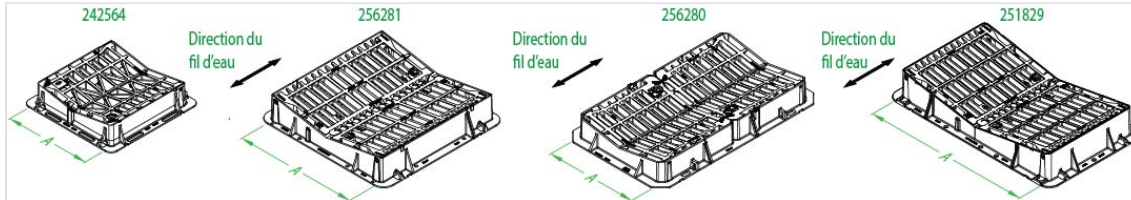

AxB and CxD: dimensions oriented along the water course

## Security:

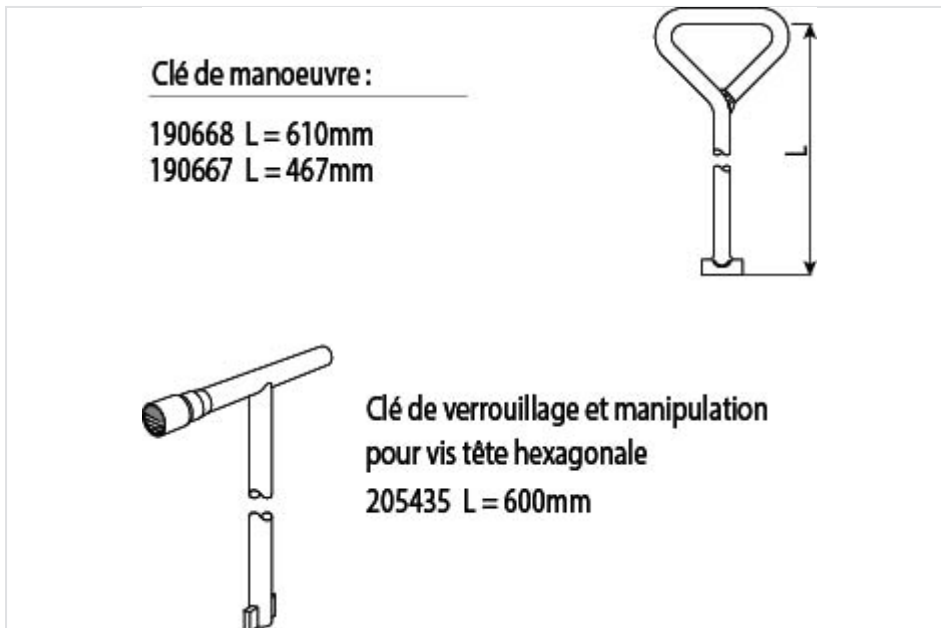

- Options: additional security locking option

*The information on this sketch is, to the best of our knowledge correct at the time of printing. However Saint-Gobain are constantly looking at ways of improving their products and services therefore reserve the right to change without prior notice, any of the data shown. Any orders placed will be subject to our Standard Conditions of Sale, available on request.*