

Plug DN300

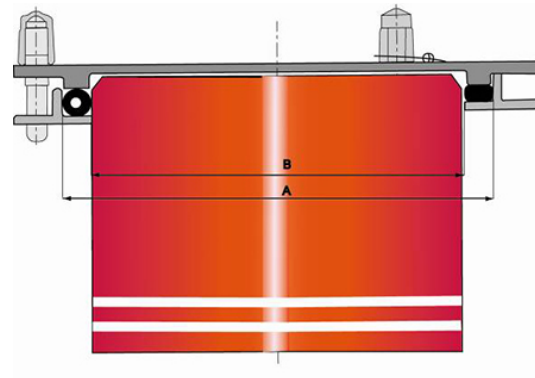

DN (mm)	A (mm)	B (mm)	Mass (kg)	References
300	377	327	17.80	TXB30RD

Field of use:

- Separate sewer system
- Application: gravity flow
- Type of effluent: wastewater
- Lastingly leak tight and impermeable
- Laying in all types of soils
- For effluents between pH1 and pH13

Main characteristics:

- External and internal coating: red epoxy powder 250µm (PECR)
- IM Gasket in Nitrile
- Fittings and joints are supplied in red-brown polyethylene bag
- EN 598 / CE Marking
- Declaration of performances [DoP-BIOGAN002EN](#)
- Designed according to the regulatory texts:
 - NF EN 476: general prescriptions for components used in the networks
 - NF EN 752: Conception of sewage projects
 - NF EN 1610: Reception of the works
 - CCTG: Fascicule 70 (sewage work)

The information on this sketch is, to the best of our knowledge correct at the time of printing. However Saint-Gobain are constantly looking at ways of improving their products and services therefore reserve the right to change without prior notice, any of the data shown. Any orders placed will be subject to our Standard Conditions of Sale, available on request.