

EUROSTOP Butterfly Valve DN150-2000 mm PN10, 16 and 25 bar

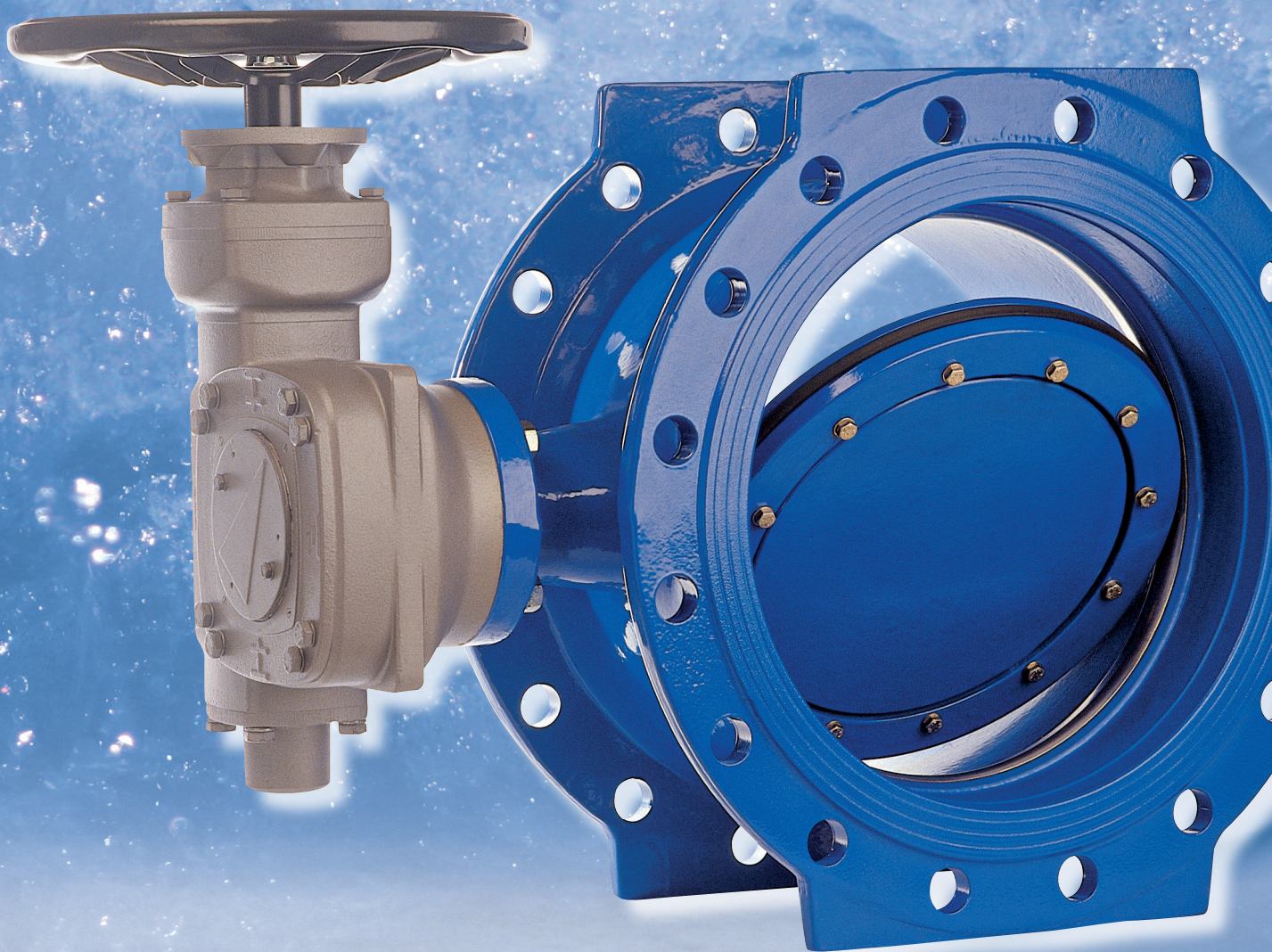

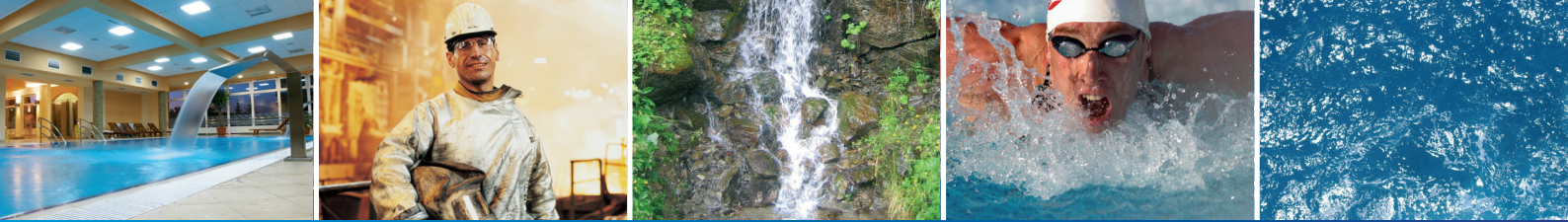

DN 150-2000 mm, PN 10, 16 and 25 bar

EUROSTOP Butterfly Valve

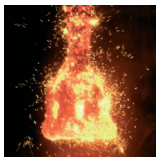

With over a century of experience, PAM is one of the world's great foundries and an international expert in the manufacture of ductile iron, a process which it pioneered and developed. PAM has a comprehensive potable water and sewage system product range to ensure complete and reliable solutions, tailored to every requirement.

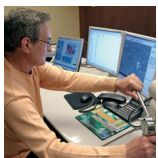

Originating from its R&D centre, PAM products are constantly in the forefront of research based innovation making them the choice for all professionals concerned with quality, durability, simplicity of installation and maintenance of their networks.



Part of the Saint-Gobain group, the Lavis plant in Italy has produced valves and couplings for different water market projects for over 75 years. Its skilled, dedicated personnel and its environment protection measures have enabled it to obtain ISO 9001:2008 and ISO 14001:2004 quality certifications as well as meeting National quality assurance standards in many countries.

Thanks to its extensive sales and distribution network, throughout

the world, PAM guarantees rapid response and the best service to all its customers.



PAM provides technical support at all stages of the project through its support staff and technical sales teams worldwide. The company's website: www.pamline.com is a source of information and help 24/7.



The EUROSTOP butterfly valve is the result of more than 30 years of experience during which we have applied innovations in design and construction techniques as well as new materials and coatings. We have created a high performance valve guaranteeing long lasting operation, simple installation and maintenance, together with complete compliance with sanitary standards.



PAM meets the requirements of its clients with complete and perfectly adapted solutions.





LIST OF CONTENTS

<u>Performances</u>	4
<u>Quality and conformity to standards</u>	8
<u>Materials</u>	10
<u>Compliance with potability regulations</u>	11
<u>Hydraulic specifications</u>	12
<u>Manual EUROSTOP Butterfly valve</u>	14
<u>Motorisable EUROSTOP Butterfly valve</u>	16
<u>Buried EUROSTOP Butterfly valve</u>	18
<u>Motorised EUROSTOP Butterfly valve</u>	20
<u>Operating accessories</u>	22
<u>AUMA gearboxes</u>	24
<u>AUMA actuators</u>	28
<u>Safety EUROSTOP Butterfly valves with counterweight</u>	30
<u>Dismantling Joints</u>	32
<u>PAMKIT</u>	35

INTRODUCTION

Flanged EUROSTOP butterfly valves in a range of DN 150 to 2000 mm and PN 10, 16 and 25 bar have been designed to isolate the flow of fluid in:

- potable water supply pipelines and treatment plants.
- transportation of filtered and recycled water.
- irrigation distribution networks.
- water-pumping stations and hydroelectric plants.
- nuclear industry, fire safety and storage facilities.
- reservoirs.

The range of EUROSTOP valves can be used for overground installation, in valve chambers and buried systems. It includes a full range of operating accessories and actuators.

EUROSTOP valves are installed all over the American continent, the Middle East and throughout Europe. They have justifiably acquired a faultless reputation for their durability, reliability and quality worldwide.





DN 150-2000 mm, PN 10, 16 and 25 bar

PERFORMANCES

○ WHY A BUTTERFLY VALVE ?

Butterfly valves are used for their:

- low height which allows their installation in areas where cover depth is minimal.
- simplicity of network operation thanks to highly reliable gearbox and actuator mechanisms.
- ability to use it as a safety valve for the network.
- perfect watertight seal in the closed position.
- simple design, low maintenance and perfect reliability.



○ WHY THE EUROSTOP BUTTERFLY VALVE ?

Length between flanges is type 14

- Protects the disc against Shocks (spelling) transportation and installation.
- Simple assembly.

Double eccentricity

- Reduces resilient seal's wear and tear ensuring detachment from the body seat ring the moment the valve begins to open.
- Reduces pressure loss in fully open position by the disc parking in a zone of reduced flow.
- Lower torque requirement to rotate the disc leads to less wear and longer life of the gasket and other elements.

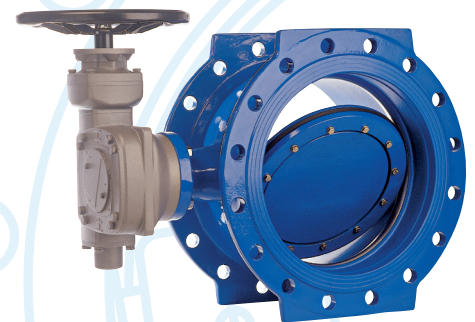

Double eccentricity

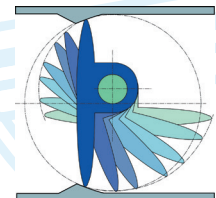

Without eccentricity

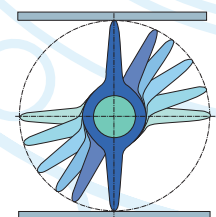

Advantages

- E 1**
- Connection between the shaft and the disc is more secure and robust.
 - Possibility of replacing the gasket without removing the disc.
 - Perfect leaktightness with no intersection between the shaft and the gasket.
 - Reduced pressure loss when the valve is open.

- E 2**
- Reduces operating torque.
 - Facilitates dismantling of the gasket.
 - Reduces frictions between the gasket and the seat ring the moment the valve begins to open.

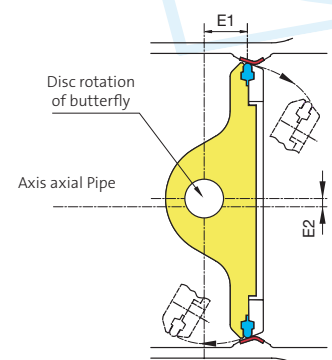

E1 : first eccentricity
E2 : second eccentricity



PERFORMANCES

○ PROFILE OF THE OPTIMIZED DISC: REDUCTION OF HEAD LOSS

Finite-element analysis design of the disc provides minimum resistance to flow when turned through 90°, hence ensuring minimal pressure loss while maintaining excellent mechanical characteristics.

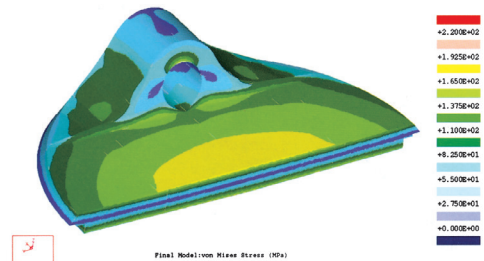
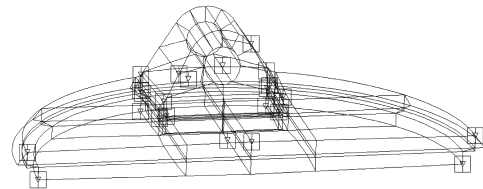

○ PROTECTION OF SHAFTS

The modern and hydrodynamic design of the disc protects the outer sections of both shafts, preventing the risk of scaling and improving their durability.



○ BIDIRECTIONAL

The butterfly valve is designed, manufactured and tested to work with fluids flowing in either direction. The seal gasket allows bi-directional tight closure.

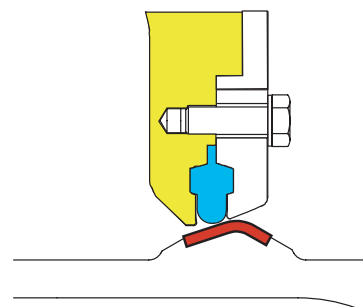
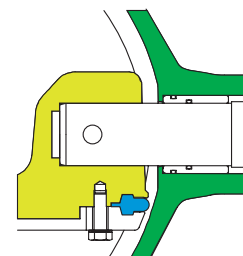



DN 150-2000 mm, PN 10, 16 and 25 bar

AUTOMATIC GASKET

The automatic gasket leaves some free space in the slot. The fluid pressure increases the sealing effect and ensures a perfect, leakproof seal. When the butterfly valve is closed and pressure is absent, the contact area between the gasket and the seat is minimised.

This design allows us:

- to increase endurance of the gasket and reduce its wear and tear
- to increase the sealing surface
- to reduce the valve's operating torque
- to ensure stability of torques

The automatic gasket retains its elastic properties longer as it incurs less mechanical stress.

The automatic gasket has high deformation flexibility when it contacts the seat as the butterfly valve closes. This reduces the closing torque.

It offers ease of maintenance in case of replacement (e.g. if the gasket is damaged by a foreign object), as no adjustment is necessary.

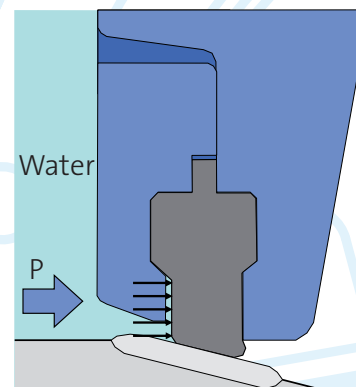
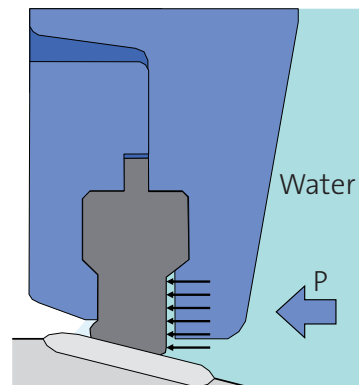

Compression of the automatic gasket under water pressure

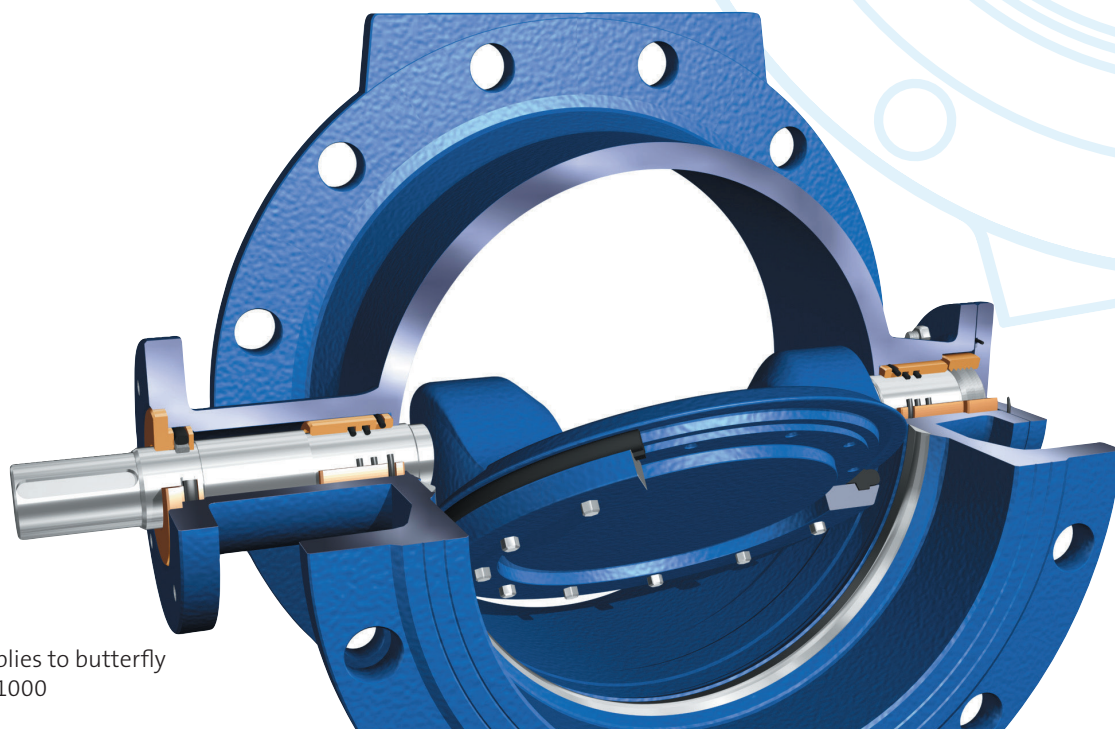

Drawing applies to butterfly valves > DN1000



PERFORMANCES

○ EPOXY COATING 250 MICRONS MIN.

To ensure an effective resistance to both soil corrosion and aggressive effects of the fluid conveyed, all EUROSTOP butterfly valves in standard version are completely coated with blue epoxy powder 250 µm min.

Process

Blast cleaning and oven heating of the body and the disc (180°C).

The epoxy powder is applied with an electrostatic spray gun to a minimum thickness of 250 microns. Upon contact with the hot surface the epoxy powder melts and polymerises ensuring a continuous film over 100% of the surface.

All components are painted prior to assembly.

Quality

Coating is controlled in process in appliance with EN 14901 :

- preparation
- quality of polymerization cross-linking.
- impact resistance, measured by steel ball.
- adhesion test (8 MPa)

Alimentarity

All components in contact with water supply are in appliance with principal European standards :

- ACS N°12ACCNV for range butterfly valve
- WRAS for coating and o-ring.

Performances

- Uniform coating at every point of each component part (interior, exterior, angles, etc.).
- High impact resistance.
- Increased durability and resistance to soil corrosion in buried applications.
- Maximum adherence.
- Optimum quality of the surface coming in contact with fluid prevents problems of abrasion and limescale.

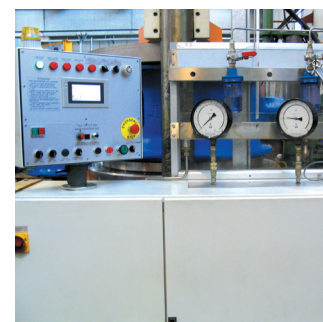
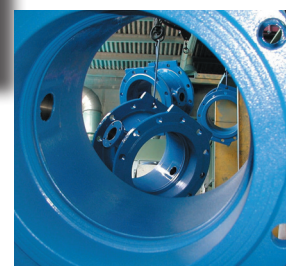
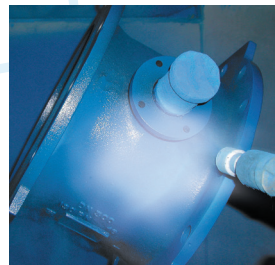



DN 150-2000 mm, PN 10, 16 and 25 bar

QUALITY AND CONFORMITY TO STANDARDS

ISO 9001:2008 QUALITY OF PRODUCTION PROCESS CERTIFICATION

In line with our policy of guaranteeing quality, Saint Gobain's manufacturing plant at Lavis, Italy holds Bureau Veritas Certification (n° 6001054) for: "Design, manufacture and marketing of products for pipelines and accessories, valves and municipal castings."



PRODUCT CERTIFICATION

EUROSTOP holds world leading certification body Bureau Veritas Certification EN 1074 1 and 2:2000 with endurance 2500 cycles (n° 220/007) that guarantees meeting all the requirements for the butterfly valves range DN 150 to 2000, PN 10-16-25 bar.



PRODUCT CONFORMITY

Ductile iron	EN 1563
Design and manufacture	EN 593
Fitness for purpose	EN 1074 - 1 and 2 : 2000
Dimensions	
- Length between flanges (type 14)	ISO 5752, EN 558-1
- Design of flanges	EN 1092-2, ISO 7005-2
- Connection valve/gearbox	EN ISO 5211
- Connection gearbox/actuator	EN ISO 5210
- Design of operating device	EN 12570
Coating	Performance according to EN14901 standard
Leaktightness tests	EN 1074-1, EN 12266-1
Resistance to water penetration into the gearbox	EN 60529



QUALITY AND CONFORMITY TO STANDARDS

○ INDIVIDUAL LEAKAGE AND MECHANICAL RESISTANCE TESTS

Each EUROSTOP butterfly valve is individually leak tested in compliance with EN 1074-1 and 2:2000 standards. The tests are carried out at the hydraulic test bench of the Lavis plant in Italy.

Disc

The disc is tested in the closed position under pressure of water equal to 1.1 PFA (Allowable operating pressure). No leakage is permitted.

Body

The disc is open and flanges are isolated, the valve is tested at water pressure 1.5 maxi value times PFA or PEA (Allowable test pressure). No leakage is permitted.

Research and Development

PAM has two R&D laboratories - in France (Pont-à-Mousson) and in Italy (Lavis) - where it continuously innovates new design and improves its product range.

Marking

All butterfly valves are identified according to EN 19 standard.

Identification

CAST MARKINGS ON THE BODY	CAST MARKINGS ON THE DISC	LABEL
<ul style="list-style-type: none"> Nominal Diameter in mm (DN) Nominal Pressure in bar (PN) Type of material (EN 1563): GJS 500-7 Reference Date of manufacture Manufacturer's logo 	<ul style="list-style-type: none"> Nominal Diameter in mm (DN) Nominal Pressure in bar (PN) Type of material (ISO 1083): GJS 500-7 Date of manufacture Manufacturer's logo 	<ul style="list-style-type: none"> Nominal Diameter in mm (DN) Nominal Pressure in bar (PN) Closing direction Reference Manufacture date : month / year Batch N°. Manufacturer's logo

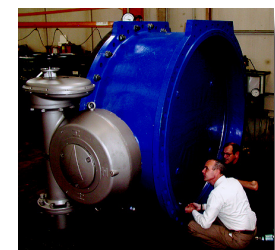
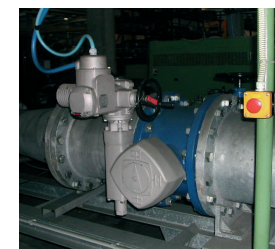



DN 150-2000 mm, PN 10, 16 and 25 bar

MATERIALS

The EUROSTOP butterfly valve benefits from materials which guarantee its excellent mechanical properties, resistance to corrosion and their compatibility with drinking water.

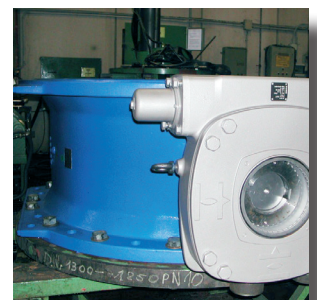
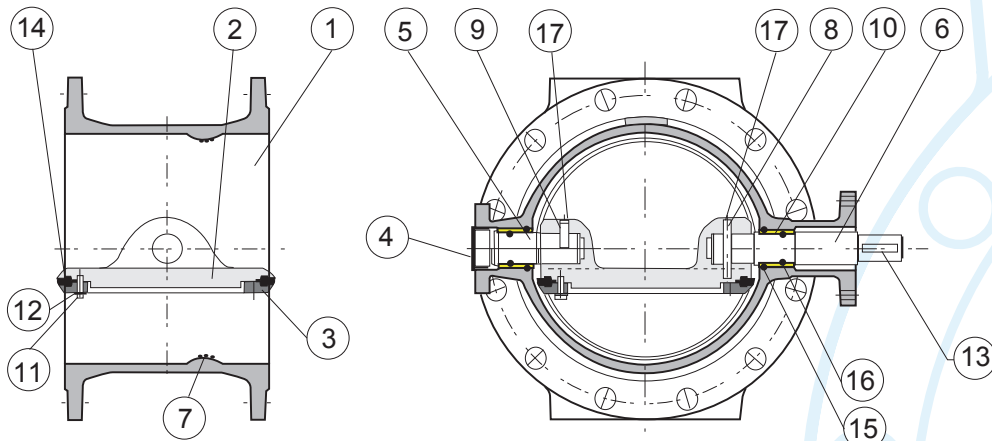

N°	DESCRIPTION	MATERIAL
1	Body	Ductile iron to EN 1563, EN 500-7 GJS
2	Disc	Ductile iron to EN 1563, EN 500-7 GJS
3	Spring clip (*)	to EN10025, S235JR Steel
4	Lid	Stainless Steel to EN 10088-2 X2CrNiMo 17,12, 2 (316L)
5	Rear Shaft	Stainless steel to EN 10088-3 X30Cr13 (420)
6	Drive Shaft	Stainless steel to EN 10088-3 X30Cr13 (420)
7	Seat	Stainless steel to EN 10088-2 X2CrNiMo 17,12,2 (316L)
8	Shaft cylindrical pin	Stainless steel to EN 10088-3 X5CrNiCuNb 16-4 (630)
9	Shaft cylindrical pin	Stainless steel to EN 10088-3 X5CrNiCuNb 16-4 (630)
10	Bearings	Bronze to EN1982 CuSn12, CC483K
11	Bolts	Stainless steel EN 10088-3 to AISI 304 (A2)
12	Spring washer	Stainless steel EN 10088-3 to AISI 304 (A2)
13	Cotter	Carbon steel C40E to EN 10083-1
14	Automatic gasket	EPDM to EN681
15	O-ring	EPDM according to EN 681-1
16		
17	Circlips	Stainless steel X5CrNi18-10 according to EN 10088-3

(*) DN 150-200: Stainless steel according to EN10088-2 X2CrNiMo 17,12, 2 (AISI 316L)

PAM is always available to consult on and discuss alternative versions and corresponding materials.



COMPLIANCE WITH POTABILITY REGULATIONS

○ COMPLIANCE OF THE PRODUCT AND ITS COMPONENTS

All materials, and in particular those in contact with the fluid, have been selected to guarantee that they will not affect drinking water characteristics. The products and their components are in conformity with their use for the provision of drinking water.

PAM holds certificates of conformity with drinking water regulations from the principal European organizations and accredited laboratories: Eurofins (France), WRAS (UK), DICHeP (Italy), KIWA (Holland) and DVGW (Germany).

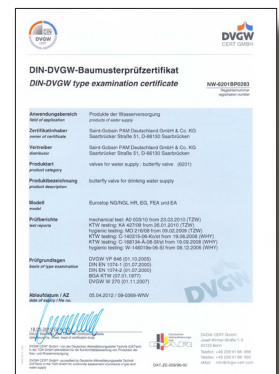
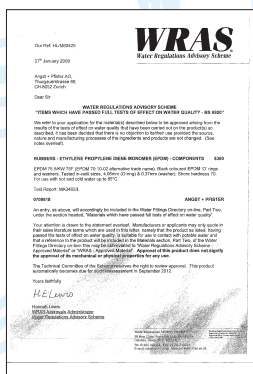
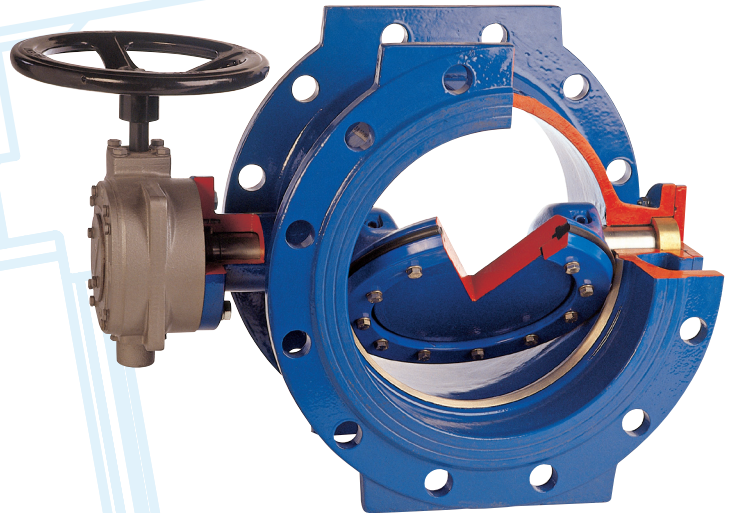

What do they validate?

These certificates approve products for their compliance with regulations applicable to water, using the following criteria:

1. Properties organoleptic : no affect on smell or taste...
2. Properties physico-chemical : no affect on colour, total suspended solids, etc.
3. Toxicity : no leaching of organic or inorganic chemicals.
4. Cytotoxicity : neither provoke nor support bacterial growth



DN 150-2000 mm, PN 10, 16 and 25 bar

HYDRAULIC SPECIFICATIONS

○ HEAD LOSS

Head loss is the result of resistance to fluid flow when it passes through the valve. It depends on the valve's design, diameter and opening angle of the disc.

Pressure loss is usually measured in "bar" or metres of water column (m.c.H₂O).



Flow factor Kv: for the EUROSTOP Butterfly valve

○ FLOW FACTOR Kv

The flow factor - Kv - is defined as the flow of water through a valve at 20°C in cubic meters per hour (m³/h) with a pressure drop of 1 bar.

It depends on valve's design, diameter and opening angle of the disc.

$$Kv = \frac{Q}{\sqrt{\Delta P}}$$

ΔP = pressure drop in bar

Q = water flow in m³/h

Kv = flow factor for the valve in m³/h

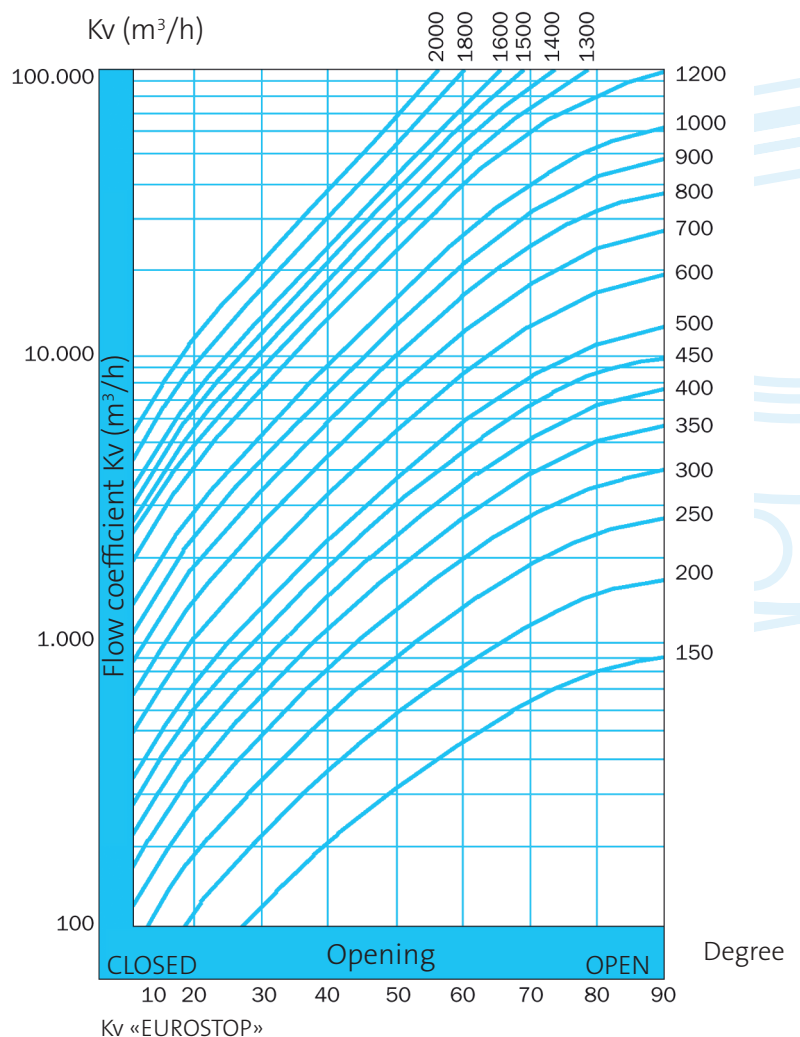



HYDRAULIC SPECIFICATIONS

○ PRESSURE DROP ΔP , FLOW Q (m³/h) BEING KNOWN

Pressure drop of a valve indicates a resistance to fluid as it flows through the valve while the disc is open.

$$\Delta P = \left(\frac{Q}{Kv} \right)^2$$

ΔP = pressure drop in bar
 Q = water flow in m³/h
 Kv = flow factor in m³/h

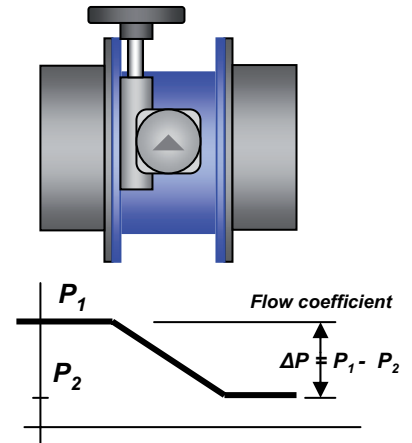

Table 1: Kv and K α factors for a fully open Butterfly valve

○ PRESSURE DROP ΔP , FLUID SPEED (m/s) BEING KNOWN

It depends on K α coefficient of a EUROSTOP valve and fluid velocity.

$$\Delta H = K\alpha \left(\frac{V^2}{2g} \right)$$

ΔH = head loss in m.c.H₂O
 $K\alpha$ = valve pressure loss coefficient
 V = fluid velocity in m/s
 g = gravitational acceleration, 9.81 m/s²

DN	Coefficient Kv (m ³ /h)		Coefficient K α	
	PN10 / 16	PN25	PN10 / 16	PN25
150	911	911	0.96	0.96
200	1698	1698	0.87	0.87
250	2761	2761	0.80	0.80
300	4119	4119	0.75	0.75
350	5789	5789	0.70	0.70
400	7787	7787	0.66	0.66
450	10129	10129	0.63	0.63
500	12834	12834	0.60	0.60
600	19394	19394	0.54	0.54
700	27608	25053	0.49	0.60
800	37619	34816	0.45	0.53
900	49584	45367	0.42	0.50
1000	63670	57769	0.39	0.47
1200	98958	87999	0.33	0.42
1400	145198	124298	0.29	0.39
1500	173077	145515	0.27	0.38
1600	204547	168978	0.25	0.36
1800	279819		0.21	
2000	374823		0.18	

Kv and K α EUROSTOP



DN 150-2000 mm, PN 10, 16 and 25 bar

MANUAL EUROSTOP BUTTERFLY VALVE

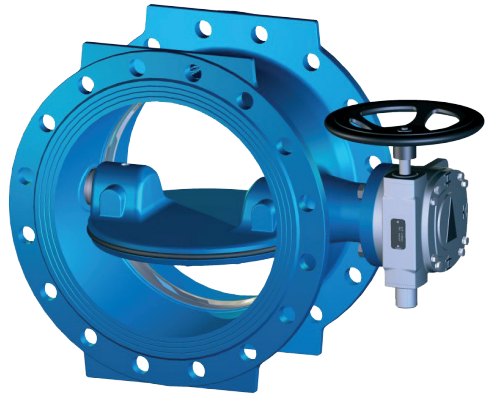

- Gearbox protection IP 68-8 (submersion up to 8 m of water).
- Gearbox Auma with position indicator.
- Clockwise Close (CC).
- Installation above ground or in a valve chamber.
- Supplied with a handwheel.
- Designed and tested to an endurance level of 2500 cycles minimum, in accordance with EN 1074-1 and 2.

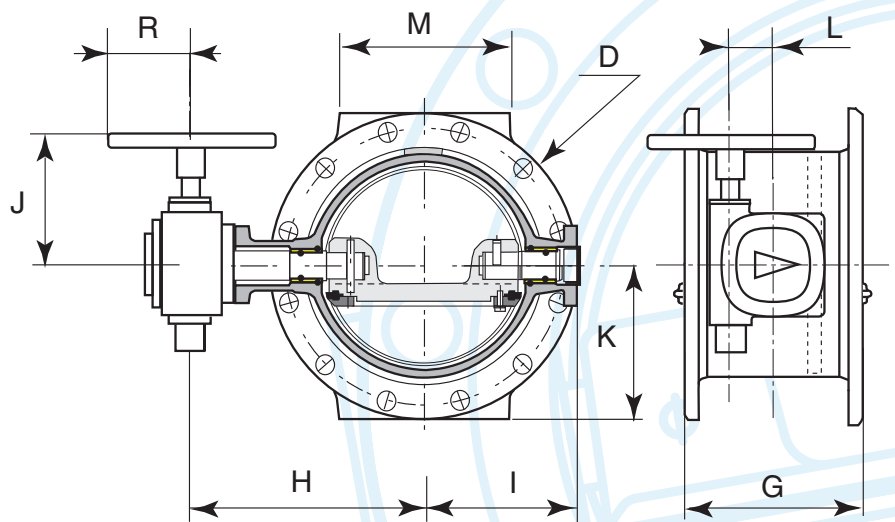

DIMENSIONS MECHANISMS AND REFERENCES

PFA
10 bar

DN	G	H	I	J	K	L	M	D	R	AUMA gearbox type + ISO5211 flange BV/gear	Weight (kg)	Reference CC
150	210	215	136	164	143	50	150	285	100	GS 50.3 – F10	35	RPB15NGAH
200	230	240	165	164	170	50	180	340	100	GS 50.3 – F10	46	RPB20NGBH
250	250	292	208	164	200	50	230	400	100	GS 50.3 – F10	67	RPB25NGBH
300	270	316	232	164	228	50	250	455	100	GS 50.3 – F10	86	RPB30NGBH
350	290	340	251	201	253	63	260	505	125	GS 63.3 – F12	111	RPB35NGBH
400	310	371	303	201	283	63	310	565	125	GS 63.3 – F12	139	RPB40NGBH
450	330	427	330	206	308	80	340	615	125	GS 80.3 – F14	183	RPB45NGBH
500	350	452	355	206	335	80	320	670	125	GS 80.3 – F14	215	RPB50NGBH
600	390	524	409	268	390	100	300	780	175	GS 100.3 – F16	302	RPB60NGBH
700	430	594	482	337	448	100	440	895	175	GS 100.3+VZ4.3 – F16	453	RPB70NGBH
800	470	675	556	342	508	125	480	1015	175	GS 125.3+VZ4.3 – F25	640	RPB80NGBH
900	510	724	623	342	558	125	570	1115	175	GS 125.3+VZ4.3 – F25	861	RPB90MGBH
1000	550	815	707	480	615	160	620	1230	175	GS 160.3+GZ160.3 – F30	1249	RPC10MGBH
1200	630	909	842	548	728	200	750	1455	175	GS 200.3+GZ200.3 – F30	1831	RPC12MGBH
1400	710	1051	953	595	838	250	850	1675	250	GS 250.3+GZ250.3 – F35	2512	RPC14MGBH
1500	750	1102	1004	595	893	250	900	1785	250	GS 250.3+GZ250.3 – F35	2873	RPC15MGBH
1600	790	1154	1056	595	958	250	950	1915	250	GS 250.3+GZ250.3 – F35	3470	RPC16MGBH
1800	870	1331	1179	755	1058	315	1000	2115	250	GS 315+GZ30 – F40 (*)	4965	203233
2000	950	1526	1367	848	1173	400	1050	2345	400	GS 315+GZ30 – F40 (*)	6560	203244

(*) IP 67

The data given in these tables may be modified without prior notice



PFA 16 bar

DN	G	H	I	J	K	L	M	D	R	AUMA gearbox type + ISO5211 flange BV/gear	Weight (kg)	Reference CC
150	210	215	136	164	143	50	150	285	100	GS 50.3 – F10	35	RPB15NGAH
200	230	240	165	164	170	50	180	340	100	GS 50.3 – F10	46	RPB20NGAH
250	250	292	208	164	200	50	230	400	100	GS 50.3 – F10	67	RPB25NGAH
300	270	321	232	201	228	63	250	455	125	GS 63.3 – F12	88	RPB30NGAH
350	290	340	272	201	260	63	260	520	125	GS 63.3 – F12	132	RPB35NGAH
400	310	407	310	206	290	80	310	580	125	GS 80.3 – F14	170	RPB40NGAH
450	330	427	330	206	320	80	340	640	125	GS 80.3 – F14	207	RPB45NGAH
500	350	470	355	248	358	100	320	715	175	GS 100.3 – F14	265	RPB50NGAH
600	390	550	438	334	420	100	300	840	175	GS 100.3+VZ4.3 – F16	414	RPB60NGAH
700	430	627	508	340	455	125	440	910	175	GS 125.3+VZ4.3 – F25	543	RPB70NGAH
800	470	713	602	415	513	160	480	1025	175	GS 160.3+GZ160.3 – F30	986	RPB80MGAH
900	510	764	653	415	563	160	570	1125	175	GS 160.3+GZ160.3 – F30	1021	RPB90MGAH
1000	550	815	748	545	628	200	620	1255	175	GS 200.3+GZ200.3 – F30	1432	RPC10MGAH
1200	630	950	852	622	743	250	750	1485	250	GS 250.3+GZ250.3 – F35	2357	RPC12MGAH
1400	710	1125	973	755	843	315	850	1685	250	GS 315+GZ30 – F40 (*)	3500	203207
1500	750	1156	1077	755	933	315	900	1865	250	GS 315+GZ30 – F40 (*)	4281	203213
1600	790	1229	1119	755	965	315	950	1930	250	GS 315+GZ30 – F40 (*)	4916	203222
1800	870	1431	1272	848	1065	400	1000	2130	400	GS 400+GZ35 – F48 (*)	6974	203237
2000	950	1526	1367	848	1173	400	1050	2345	400	GS 400+GZ35 – F48 (*)	8500	203248

(*) IP 67

PFA 25 bar

DN	G	H	I	J	K	L	M	D	R	AUMA gearbox type + ISO5211 flange BV/gear	Weight (kg)	Reference CC
150	210	217	141	164	150	50	150	300	100	GS 50.3 – F10	39	RPB15NGDH
200	230	269	183	164	180	50	180	360	100	GS 50.3 – F10	63	RPB20NGDH
250	250	297	207	201	213	63	230	425	125	GS 63.3 – F12	88	RPB25NGDH
300	270	321	252	201	243	63	250	485	125	GS 63.3 – F12	120	RPB30NGDH
350	290	376	278	206	278	80	310	555	125	GS 80.3 – F14	174	RPB35NGDH
400	310	425	309	248	310	100	310	620	175	GS 100.3 – F14	221	RPB40NGDH
450	330	471	359	334	335	100	340	670	175	GS 100.3+VZ4.3 – F16	300	RPB45NGDH
500	350	498	386	334	365	100	320	730	175	GS 100.3+VZ4.3 – F16	348	RPB50NGDH
600	390	581	461	340	423	125	380	845	175	GS 125.3+VZ4.3 – F25	636	RPB60NGDH
700	430	665	552	415	480	160	470	960	175	GS 160.3+GZ160.3 – F30	975	RPB70MGDH
800	470	713	645	545	543	200	480	1085	175	GS 200.3+GZ200.3 – F30	1130	RPB80MGDH
900	510	788	695	545	593	200	570	1185	175	GS 200.3+GZ200.3 – F35	1693	RPB90MGDH
1000	550	856	756	622	660	250	620	1320	250	GS 250.3+GZ250.3 – F35	2091	RPC10MGDH
1200	630	1024	872	750	765	315	750	1530	250	GS 315+GZ30 – F40 (*)	3398	RPC12MGDH
1400	710	1126	1016	750	878	315	850	1755	250	GS 315+GZ30 – F40 (*)	4067	RPC14MGDH
1500	750	1186	1078	843	933	400	900	1865	400	GS 400+GZ35 – F48 (*)	6052	203217
1600	790	1328	1169	843	988	400	950	1975	400	GS 400+GZ35 – F48 (*)	6200	RPC16MGDH

(*) IP 67

The data given in these tables may be modified without prior notice



DN 150-2000 mm, PN 10, 16 and 25 bar

MOTORISABLE EUROSTOP BUTTERFLY VALVE

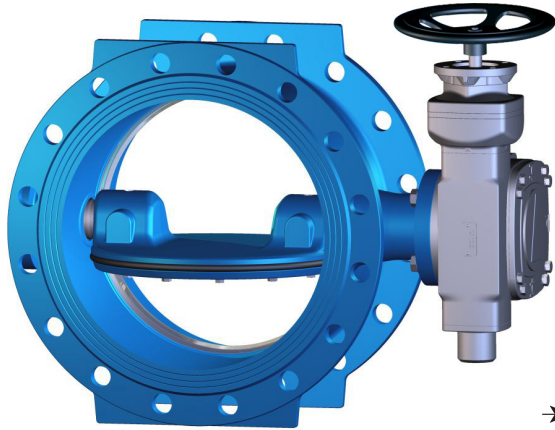

- Gearbox protection IP 68-8 (submersion up to 8 m of water).
- Gearbox AUMA with position indicator.
- Mounting flange for accessories F10 or F14 according to the EN ISO5210 standard.
- Clockwise Close (CC).
- Installation above ground or in a valve chamber.
- Supplied with a handwheel.
- Designed and tested to an endurance level of 2500 cycles minimum, in accordance with EN 1074-1 and 2.

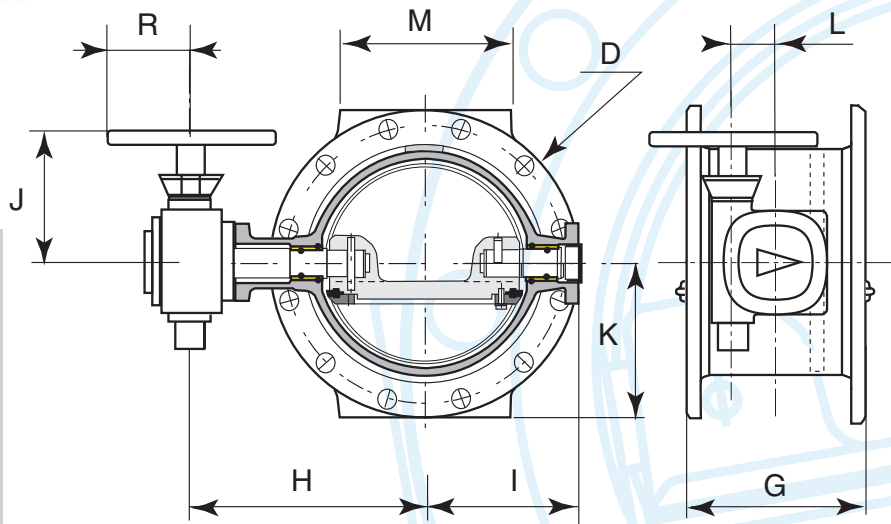

Gearbox equipped with a flange in accordance with UNE-EN ISO 5210 standard which enables mounting of an actuator. The flange is sized at the factory specifically for each installation:

Flange F10: with Ø20 shaft with key connection and slot for AUMA type SA 07.6 or SA 10.2 actuator.

Flange F14: with Ø30 shaft with key connection and slot for AUMA type SA 14 actuator.

DIMENSIONS MECHANISMS AND REFERENCES

PFA
10 bar

DN	G	H	I	J	K	L	M	D	R	AUMA gearbox type + ISO5211 flange BV/gear	Weight (kg)	Reference CC
150	210	215	136	164	143	50	150	285	100	GS 50.3 – F10	35	RPB15NHCH
200	230	240	165	164	170	50	180	340	100	GS 50.3 – F10	46	RPB20NHBH
250	250	294	208	201	200	63	230	400	125	GS 50.3 – F10	67	RPB25NCBH
300	270	321	232	201	228	63	250	455	125	GS 50.3 – F10	86	RPB30NCBH
350	290	340	251	201	253	63	260	505	125	GS 63.3 – F12	111	RPB35NHBH
400	310	373	303	206	283	80	310	565	125	GS 63.3 – F12	139	RPB40NCBH
450	330	445	330	337	308	100	340	615	175	GS 80.3 – F14	183	RPB45NCBH
500	350	470	355	337	335	100	320	670	175	GS 80.3 – F14	215	RPB50NCBH
600	390	524	409	337	390	100	300	780	175	GS 100.3+VZ4.3 – F16	302	RPB60NHBH
700	430	594	482	342	448	125	440	895	175	GS 100.3+VZ4.3 – F16	453	RPB70NCBH
800	470	675	556	342	508	125	480	1015	175	GS 125.3+VZ4.3 – F25	640	RPB80NHBH
900	510	724	623	418	558	160	570	1115	175	GS 160.3+GZ160.3 – F25	861	RPB90MHBH
1000	550	815	707	418	615	160	620	1230	175	GS 160.3+GZ160.3 – F30	1249	RPC10MHBH
1200	630	909	842	548	728	200	750	1455	175	GS 200.3+GZ200.3 – F30	1831	RPC12MHBH
1400	710	1051	953	595	838	250	850	1675	250	GS 250.3+GZ250.3 – F35	2512	RPC14MQBH
1500	750	1102	1004	595	893	250	900	1785	250	GS 250.3+GZ250.3 – F35	2873	RPC15MQBH
1600	790	1154	1056	595	958	250	950	1915	250	GS 250.3+GZ250.3 – F35	3470	RPC16MQBH
1800	870	1331	1179	755	1058	315	1000	2115	250	GS 315+GZ30 – F40 (*)	4965	165541
2000	950	1526	1367	848	1173	400	1050	2345	400	GS 400+GZ35 – F48 (*)	6560	203241

(*) IP 67

The data given in these tables may be modified without prior notice



PFA 16 bar

DN	G	H	I	J	K	L	M	D	R	AUMA gearbox type + ISO5211 flange BV/gear	Weight (kg)	Reference CC
150	210	215	136	164	143	50	150	285	100	GS 50.3 – F10	35	RPB15NHCH
200	230	240	165	164	170	50	180	340	100	GS 50.3 – F10	46	RPB20NHAH
250	250	294	208	201	200	63	230	400	125	GS 50.3 – F10	67	RPB25NCAH
300	270	321	232	201	228	63	250	455	125	GS 63.3 – F12	88	RPB30NHAH
350	290	342	272	206	260	80	260	520	125	GS 63.3 – F12	132	RPB35NCAH
400	310	425	310	337	290	100	310	580	175	GS 80.3 – F14	170	RPB40NCAH
450	330	445	330	337	320	100	340	640	175	GS 100.3+VZ4.3 – F14	207	RPB45NHAH
500	350	470	355	337	358	100	320	715	175	GS 100.3+VZ4.3 – F14	265	RPB50NHAH
600	390	550	438	342	420	125	300	840	175	GS 100.3+VZ4.3 – F16	414	RPB60NCAH
700	430	627	508	418	455	160	440	910	175	GS 125.3+VZ4.3 – F25	543	RPB70NCAH
800	470	713	602	418	513	160	480	1025	175	GS 160.3+GZ160.3 – F30	926	RPB80MHAH
900	510	764	653	548	563	200	570	1125	175	GS 160.3+GZ160.3 – F30	1152	RPB90MCAH
1000	550	815	748	548	628	200	620	1255	175	GS 200.3+GZ200.3 – F30	1479	RPC10MHAH
1200	630	950	852	595	743	250	750	1485	250	GS 250.3+GZ250.3 – F35	2357	RPC12MHAH
1400	710	1125	973	755	843	315	850	1685	250	GS 315+GZ30 – F40 (*)	3590	RPC14MHAH
1500	750	1156	1077	755	933	315	900	1865	250	GS 315+GZ30 – F40 (*)	4020	RPC15MHAH
1600	790	1229	1119	755	965	315	950	1930	250	GS 315+GZ30 – F40 (*)	4920	RPC16MHAH
1800	870	1431	1272	848	1065	400	1000	2130	400	GS 400+GZ35 – F48 (*)	6974	RPC18MHAH
2000	950	1526	1367	848	1173	400	1050	2345	400	GS 400+GZ35 – F48 (*)	8353	RPC20MHAH

(*) IP 67

PFA 25 bar

DN	G	H	I	J	K	L	M	D	R	AUMA gearbox type + ISO5211 flange BV/gear	Weight (kg)	Reference CC
150	210	217	141	164	150	50	150	300	100	GS 50.3 – F10	39	RPB15NHDDH
200	230	274	183	201	180	63	180	360	125	GS 50.3 – F10	63	RPB20NCDH
250	250	297	207	201	213	63	230	425	125	GS 63.3 – F12	88	RPB25NHDDH
300	270	323	252	206	243	80	250	485	125	GS 63.3 – F12	120	RPB30NCDH
350	290	394	278	337	278	100	310	555	175	GS 80.3 – F14	174	RPB35NCDH
400	310	425	309	337	310	100	310	620	175	GS 100.3+VZ4.3 – F14	221	RPB40NHDDH
450	330	471	359	342	335	125	340	670	175	GS 100.3+VZ4.3 – F16	300	RPB45NCDH
500	350	498	386	342	365	125	320	730	175	GS 100.3+VZ4.3 – F16	348	RPB50NCDH
600	390	581	461	418	423	160	380	845	175	GS 160.3+GZ160.3 – F25	520	RPB60NHDDH
700	430	665	552	418	480	160	470	960	175	GS 160.3+GZ160.3 – F30	975	RPB70MHDH
800	470	713	645	548	543	200	480	1085	175	GS 200.3+GZ200.3 – F30	1243	RPB80MHDH
900	510	788	695	548	593	200	570	1185	175	GS 200.3+GZ200.3 – F35	1693	RPB90MHDH
1000	550	856	756	595	660	250	620	1320	250	GS 250.3+GZ250.3 – F35	2091	RPC10MQDH
1200	630	1024	872	755	765	315	750	1530	250	GS 315+GZ30 – F40 (*)	3430	RPC12MHDH
1400	710	1126	1016	755	878	315	850	1755	250	GS 315+GZ30 – F40 (*)	4067	RPC14MHDH
1500	750	1186	1078	848	933	400	900	1865	400	GS 400+GZ35 – F48 (*)	6052	203216
1600	790	1328	1169	848	988	400	950	1975	400	GS 400+GZ35 – F48 (*)	6200	RPC16MHDH

(*) IP 67

The data given in these tables may be modified without prior notice



DN 150-2000 mm, PN 10, 16 and 25 bar

BURIED EUROSTOP BUTTERFLY VALVE

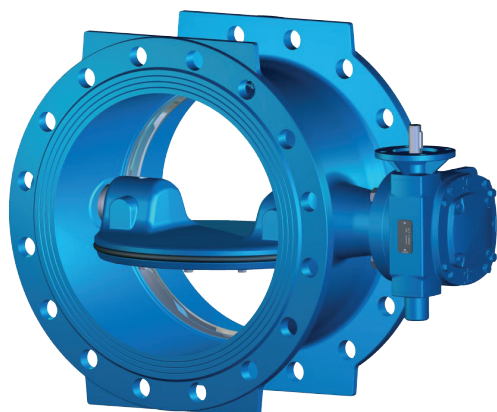

- Gearbox protection IP 68-8 (submersion up to 8 m of water).
- Gearbox protected with additional blue epoxy 80 microns coating.
- Without a position indicator.
- Mounting flange for accessories according to the EN ISO5210 standard, F10 or F14.
- Clockwise Close (CC).
- Buried installation.
- Supplied with an extension spindle.
- Designed and tested to an endurance level of 2500 cycles minimum, in accordance with EN 1074-1 and 2.

Gearbox equipped with a flange in accordance with UNE-EN ISO 5210 standard which enables installation of operating accessories. The flange is sized at the factory specifically for each installation:

Flange F10: with Ø20 shaft with slot for Ø33/42 manual operating device.

Flange F14: with Ø30 shaft with slot for Ø50/60 manual operating device.

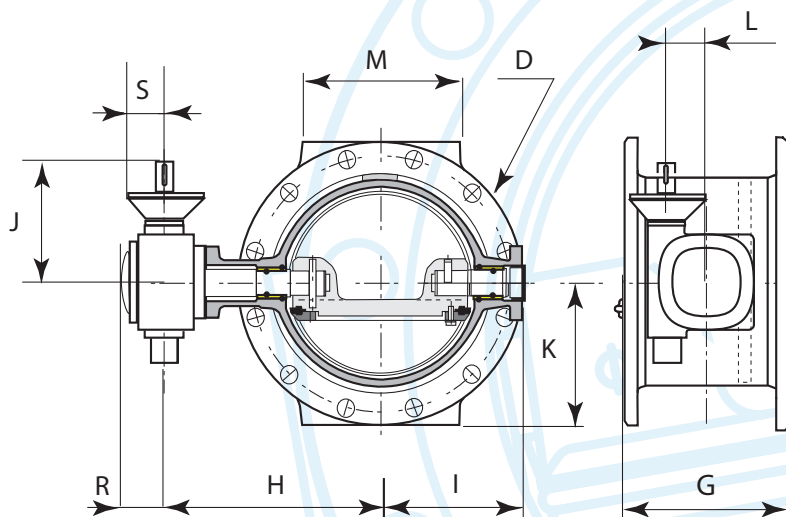

DIMENSIONS MECHANISMS AND REFERENCES

PFA 10 bar

DN	G	H	I	J	K	L	M	D/ØN	R	S	AUMA gearbox type + ISO5211 flange BV/gear	Weight (kg)	References CC
150	210	217	136	165	143	63	150	285	62	62.5	GS 63.3 – F10	36	RPB15NFCH
200	230	241	165	165	170	63	180	340	62	62.5	GS 63.3 – F10	49	RPB20NFBH
250	250	294	208	165	200	63	230	400	62	62.5	GS 63.3 – F10	81	RPB25NFBH
300	270	318	232	165	228	63	250	455	62	62.5	GS 63.3 – F10	101	RPB30NFBH
350	290	340	251	162	253	63	260	505	62	62.5	GS 63.3 – F12	123	RPB35NFBH
400	310	371	303	162	283	63	310	565	62	62.5	GS 63.3 – F12	159	RPB40NFBH
450	330	427	330	170	308	80	340	615	66	62.5	GS 80.3 – F14	223	RPB45NFBH
500	350	452	355	170	335	80	320	670	66	62.5	GS 80.3 – F14	254	RPB50NFBH
600	390	524	409	230	390	100	300	780	84	62.5	GS 100.3 – F16	319	RPB60NFBH
700	430	594	482	299	448	100	440	895	84	62.5	GS 100.3+VZ4.3 – F16	497	RPB70NFBH
800	470	675	556	304	508	125	480	1015	88	62.5	GS 125.3+VZ4.3 – F25	793	RPB80NFBH
900	510	724	623	304	558	125	570	1115	88	62.5	GS 125.3+VZ4.3 – F25	861	RPB90MFBH
1000	550	815	707	335	615	160	620	1230	116	62.5	GS 160.3+GZ160.3 – F30	1249	RPC10MFBH
1200	630	909	842	420	728	200	750	1455	121	62.5	GS 200.3+GZ200.3 – F30	1831	RPC12MFBH
1400	710	1051	953	500	838	250	850	1675	146	87.5	GS 250.3+GZ250.3 – F35	2515	RPC14MFBH
1500	750	1102	1004	500	893	250	900	1785	146	87.5	GS 250.3+GZ250.3 – F35	2873	RPC15MFBH
1600	790	1154	1056	500	958	250	950	1915	146	87.5	GS 250.3+GZ250.3 – F35	3470	RPC16MFBH
1800	870	1331	1179	725	1058	315	1000	2115	200	62.5	GS 315+GZ30 – F40 (*)	4965	RPC18MFBH
2000	950	1526	1367	826	1173	400	1050	2345	240	87.5	GS 400+GZ35 – F48 (*)	6560	RPC20MFBH

(*) IP 67

The data given in these tables may be modified without prior notice



PFA 16 bar

DN	G	H	I	J	K	L	M	D/øN	R	S	AUMA gearbox type + ISO5211 flange BV/gear	Weight (kg)	Reference CC
150	210	217	136	165	143	63	150	285	62	62.5	GS 63.3 – F10	36	RPB15NFCH
200	230	241	165	165	170	63	180	340	62	62.5	GS 63.3 – F10	49	RPB20NFAH
250	250	294	208	165	200	63	230	400	62	62.5	GS 63.3 – F10	81	RPB25NFAH
300	270	318	232	162	228	63	250	455	62	62.5	GS 63.3 – F12	101	RPB30NFAH
350	290	340	272	162	260	63	260	520	62	62.5	GS 63.3 – F12	150	RPB35NFAH
400	310	407	310	66	290	80	310	580	66	62.5	GS 80.3 – F14	216	RPB40NFAH
450	330	427	330	66	320	80	340	640	66	62.5	GS 80.3 – F14	252	RPB45NFAH
500	350	470	355	230	358	100	320	715	84	62.5	GS 100.3 – F14	307	RPB50NFAH
600	390	550	438	299	420	100	300	840	84	62.5	GS 100.3+VZ4.3 – F16	476	RPB60NFAH
700	430	627	508	304	455	125	440	910	88	62.5	GS 125.3+VZ4.3 – F25	675	RPB70NFAH
800	470	713	602	335	513	160	480	1025	116	62.5	GS 160.3+GZ160.3 – F30	986	RPB80MFAH
900	510	764	653	335	563	160	570	1125	116	62.5	GS 160.3+GZ160.3 – F30	1152	RPB90MFAH
1000	550	815	748	420	628	200	620	1255	121	62.5	GS 200.3+GZ200.3 – F30	1479	RPC10MFAH
1200	630	950	852	500	743	250	750	1485	146	87.5	GS 250.3+GZ250.3 – F35	2357	RPC12MFAH
1400	710	1125	973	725	843	315	850	1685	200	62.5	GS 315+GZ30 – F40 (*)	3590	RPC14MFAH
1500	750	1156	1077	725	933	315	900	1865	200	62.5	GS 315+GZ30 – F40 (*)	5582	RPC15MFAH
1600	790	1229	1119	725	965	315	950	1930	200	87.5	GS 315+GZ30 – F40 (*)	4916	RPC16MFAH
1800	870	1431	1272	826	1065	400	1000	2130	240	87.5	GS 400+GZ35 – F48 (*)	6974	RPC18MFAH
2000	950	1526	1367	826	1173	400	1050	2345	240	87.5	GS 400+GZ35 – F48 (*)	8353	RPC20MFAH

(*) IP 67

PFA 25 bar

DN	G	H	I	J	K	L	M	D/øN	R	S	AUMA gearbox type + ISO5211 flange BV/gear	Weight (kg)	Reference CC
150	210	219	141	165	150	63	150	300	62	62.5	GS 63.3 – F10	43	RPB15NFDH
200	230	219	183	165	180	63	180	360	62	62.5	GS 63.3 – F10	73	RPB20NFDH
250	250	297	207	162	213	63	230	425	62	62.5	GS 63.3 – F12	93	RPB25NFDH
300	270	321	252	162	243	63	250	485	62	62.5	GS 63.3 – F12	138	RPB30NFDH
350	290	376	278	170	278	80	310	555	66	62.5	GS 80.3 – F14	213	RPB35NFDH
400	310	425	309	230	310	100	310	620	84	62.5	GS 100.3 – F14	249	RPB40NFDH
450	330	471	359	299	335	100	340	670	84	62.5	GS 100.3+VZ4.3 – F16	280	RPB45NFDH
500	350	498	386	299	365	100	320	730	84	62.5	GS 100.3+VZ4.3 – F16	404	RPB50NFDH
600	390	581	461	304	423	125	380	845	88	62.5	GS 125.3+VZ4.3 – F25	636	RPB60NFDH
700	430	665	552	335	480	160	470	960	116	62.5	GS 160.3+GZ160.3 – F30	975	RPB70MFDH
800	470	713	645	420	543	200	480	1085	121	62.5	GS 200.3+GZ200.3 – F30	1243	RPB80MFDH
900	510	788	695	420	593	200	570	1185	121	62.5	GS 200.3+GZ200.3 – F35	1693	RPB90MFDH
1000	550	856	756	500	660	250	620	1320	146	87.5	GS 250.3+GZ250.3 – F35	2091	RPC10MFDH
1200	630	1024	872	725	765	315	750	1530	200	62.5	GS 315+GZ30 – F40 (*)	3400	RPC12MFDH
1400	710	1126	1016	725	878	315	850	1755	200	87.5	GS 315+GZ30 – F40 (*)	4067	RPC14MFDH
1500	750	1186	1078	826	933	400	900	1865	240	87.5	GS 400+GZ35 – F48 (*)	6052	RPC15MFDH
1600	790	1328	1169	826	988	400	950	1975	240	87.5	GS 400+GZ35 – F48 (*)	6200	RPC16MFDH

(*) IP 67

The data given in these tables may be modified without prior notice



DN 150-2000 mm, PN 10, 16 and 25 bar

MOTORISED EUROSTOP BUTTERFLY VALVE

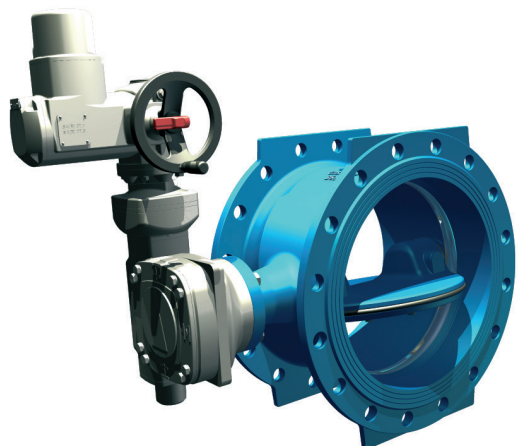

Protection of gearbox IP 68-8 (submersion up to 8 m of water) and actuator IP 68 (submersion up to 8 m of water, during 96 hours and 10 operations)

- With position indicator.
- Clockwise Close (CC).
- For installation above ground and in non-flooded chambers.
- Designed and tested to an endurance level of 2500 cycles minimum, in accordance with EN 1074-1 and 2.

- Equipped with standard AUMA NORM version SA actuator(*):
- Supply voltage 400 V, 3-phase 50Hz.
- Motor duty type: short-time duty S2 - 15 minutes (according to IEC 34-1).
- Winding isolation F class.
- Protection against overheating by thermostiches.
- Two limit switches SPDT.
- Two torque switches SPDT.
- Blinker switch feedback signal.
- Disengaging emergency handwheel.

(*Please consult us for other equipment.

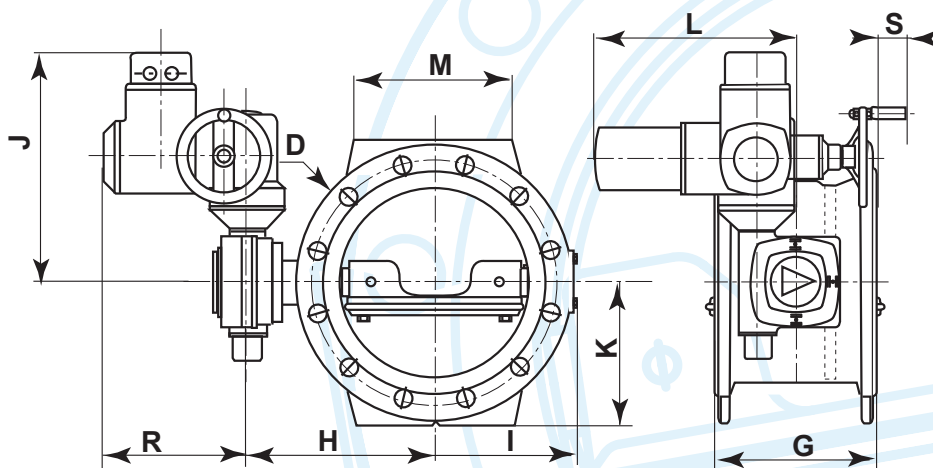

DIMENSIONS MECHANISMS AND REFERENCES

PFA
10 bar

DN	G	H	I	J	K	L	M	D/øN	R	S	AUMA gearbox type + ISO5211 flange BV/gear	Weight (kg)	Reference CC
150	210	215	136	375	143	315	150	285	237	199	GS 50.3 – F10	56	RPB15NECH
200	230	240	165	375	170	315	180	340	237	199	GS 50.3 – F10	67	RPB20NEBH
250	250	294	208	401	200	328	230	400	237	186	GS 50.3 – F10	83	RPB25NDBH
300	270	321	232	401	228	328	250	455	237	186	GS 50.3 – F10	104	RPB30NDBH
350	290	340	251	401	253	328	260	505	237	186	GS 63.3 – F12	132	RPB35NEBH
400	310	373	303	408	283	362	310	565	247	174	GS 63.3 – F12	161	RPB40NDBH
450	330	445	330	535	308	365	340	615	237	149	GS 80.3 – F14	181	RPB45NDBH
500	350	470	355	535	335	365	320	670	237	149	GS 80.3 – F14	230	RPB50NDBH
600	390	524	409	535	390	365	300	780	237	149	GS 100.3+VZ4.3 – F16	331	RPB60NEBH
700	430	594	482	542	448	407	440	895	247	129	GS 100.3+VZ4.3 – F16	472	RPB70NDBH
800	470	675	556	542	508	407	480	1015	247	129	GS 125.3+VZ4.3 – F25	665	RPB80NEBH
900	510	724	623	618	558	442	570	1115	247	94	GS 160.3+GZ160.3 – F25	861	RPB90MEBH
1000	550	815	707	618	615	442	600	1230	247	94	GS 160.3+GZ160.3 – F30	1249	RPC10MEBH
1200	630	909	842	748	728	482	750	1455	247	54	GS 200.3+GZ200.3 – F30	1831	RPC12MEBH
1400	710	1051	953	842	838	634	850	1675	285	79	GS 250.3+GZ250.3 – F35	2544	RPC14MEBH
1500	750	1102	1004	842	893	634	900	1785	285	79	GS 250.3+GZ250.3 – F35	2905	RPC15MEBH
1600	790	1154	1056	842	958	634	950	1915	285	79	GS 250.3+GZ250.3 – F35	3520	RPC16MEBH
1800	870	1331	1179	962	1058	597	1000	2115	247	-	GS 315+GZ30 – F40 (*)	4997	RPC18MEBH
2000	950	1526	1367	1077	1173	784	1050	2345	285	-	GS 315+GZ30 – F40 (*)	8418	RPC20MEBH

(* IP 67

The data given in these tables may be modified without prior notice

PFA
16 bar

DN	G	H	I	J	K	L	M	D/øN	R	S	AUMA gearbox type + ISO5211 flange BV/gear	Weight (kg)	Reference CC
150	210	215	136	375	143	315	150	285	237	199	GS 50.3 – F10	56	RPB15NECH
200	230	240	165	375	170	315	180	340	237	199	GS 50.3 – F10	67	RPB20NEAH
250	250	294	208	401	200	328	230	400	237	186	GS 50.3 – F10	85	RPB25NDAH
300	270	321	232	401	228	328	250	455	237	186	GS 63.3 – F12	111	RPB30NEAH
350	290	342	272	406	260	362	260	520	247	174	GS 63.3 – F12	156	RPB35NDAH
400	310	425	310	535	290	365	310	580	237	149	GS 80.3 – F14	185	RPB40NDAH
450	330	445	330	535	320	365	340	640	237	149	GS 100.3+VZ4.3 – F14	248	RPB45NEAH
500	350	470	355	535	358	365	320	715	237	149	GS 100.3+VZ4.3 – F14	294	RPB50NEAH
600	390	550	438	542	420	407	300	840	247	129	GS 100.3+VZ4.3 – F16	440	RPB60NDAH
700	430	627	508	616	455	425	420	910	237	89	GS 125.3+VZ4.3 – F25	566	RPB70NDAH
800	470	713	602	618	513	442	450	1025	247	94	GS 160.3+GZ160.3 – F30	986	RPB80MEAH
900	510	764	653	748	563	482	550	1125	247	54	GS 200.3+GZ200.3 – F30	1044	RPB90MEAH
1000	550	815	748	748	628	482	600	1255	247	54	GS 200.3+GZ200.3 – F30	1479	RPC10MEAH
1200	630	950	852	844	743	634	750	1485	285	79	GS 250.3+GZ250.3 – F35	2389	RPC12MEAH
1400	710	1125	973	1000	843	597	850	1685	247	-	GS 315+GZ30 – F40 (*)	3622	RPC14MEAH
1500	750	1156	1077	1001	933	597	900	1865	247	-	GS 315+GZ30 – F40 (*)	4313	RPC15MEAH
1600	790	1229	1119	1041	965	699	950	1930	285	14	GS 315+GZ30 – F40 (*)	4948	RPC16MEAH
1800	870	1431	1272	1141	1065	784	1000	2130	285	-	GS 400+GZ35 – F48 (*)	7039	RPC18MEAH
2000	950	1526	1367	1141	1173	784	1050	2345	285	-	GS 400+GZ35 – F48 (*)	8418	RPC20MEAH

(*) IP 67

PFA
25 bar

DN	G	H	I	J	K	L	M	D/øN	R	S	AUMA gearbox type + ISO5211 flange BV/gear	Weight (kg)	Reference CC
150	210	217	141	376	150	315	150	300	237	199	GS 50.3 – F10	60	RPB15NEDH
200	230	274	183	401	180	328	180	360	237	186	GS 50.3 – F10	81	RPB20NDDH
250	250	297	207	401	213	328	230	425	237	186	GS 63.3 – F12	109	RPB25NEDH
300	270	323	252	406	243	362	250	485	247	174	GS 63.3 – F12	144	RPB30NDDH
350	290	394	278	535	278	365	310	555	237	149	GS 80.3 – F14	189	RPB35NDDH
400	310	425	309	535	310	365	310	620	237	149	GS 100.3+VZ4.3 – F14	250	RPB40NEDH
450	330	471	359	540	335	390	340	670	237	124	GS 100.3+VZ4.3 – F16	321	RPB45NDDH
500	350	498	386	542	365	407	300	730	247	124	GS 100.3+VZ4.3 – F16	374	RPB50NDDH
600	390	581	461	618	423	442	350	845	247	94	GS 160.3+GZ160.3 – F25	593	RPB60NEDH
700	430	665	552	618	480	442	420	960	247	94	GS 160.3+GZ160.3 – F30	975	RPB70MEDH
800	470	713	645	748	543	482	450	1085	247	54	GS 200.3+GZ200.3 – F30	1243	RPB80MEDH
900	510	788	695	748	593	482	550	1185	247	54	GS 200.3+GZ200.3 – F35	1725	RPB90MECDH
1000	550	856	756	844	660	634	620	1320	285	79	GS 250.3+GZ250.3 – F35	2123	RPC10MEDH
1200	630	1024	872	962	765	597	760	1530	247	-	GS 315+GZ30 – F40 (*)	3430	RPC12MEDH
1400	710	1126	1016	1000	878	699	850	1755	285	14	GS 315+GZ30 – F40 (*)	4600	203209
1500	750	1186	1078	1081	933	784	900	1865	285	-	GS 400+GZ35 – F48 (*)	6117	203215
1600	790	1328	1169	1081	988	784	950	1975	285	-	GS 400+GZ35 – F48 (*)	6265	203224

(*) IP 67

The data given in these tables may be modified without prior notice



DN 150-2000 mm, PN 10, 16 and 25 bar

OPERATING ACCESSORIES

The accessories described below serve for operating the butterfly valves installed in chambers or underground.

Spindle with handwheel (picture 1) or motorised (picture 2)
Cap top and T-key operation (see pictures 3 and 4).

○ Components

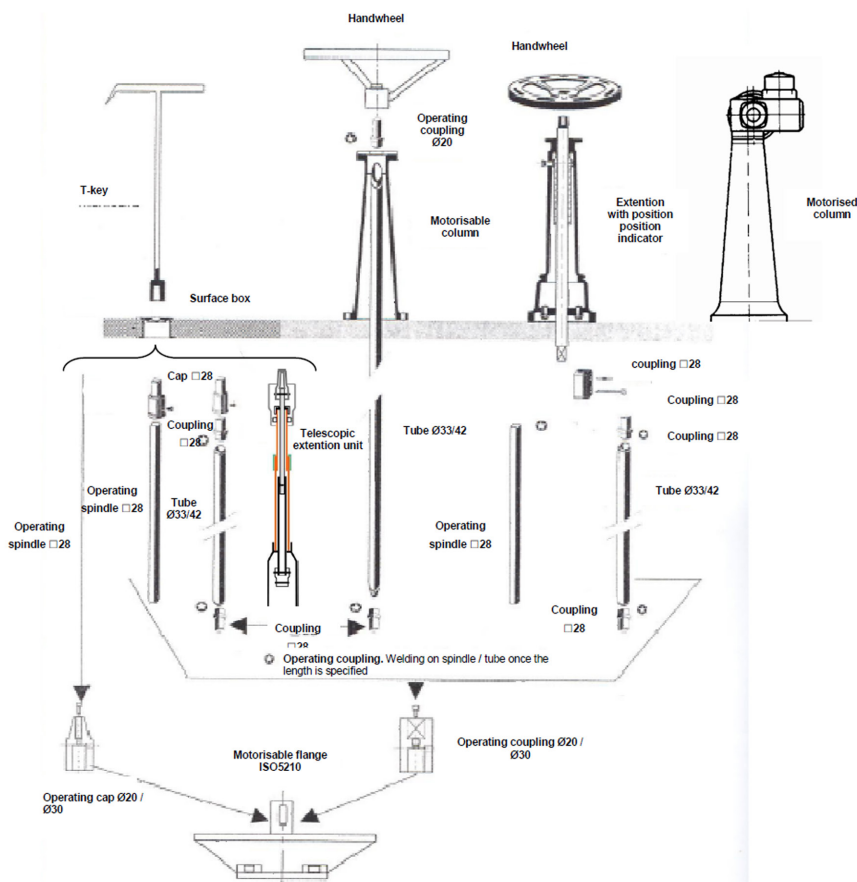

Picture 1. Spindle with handwheel



Picture 2. Motorised spindle

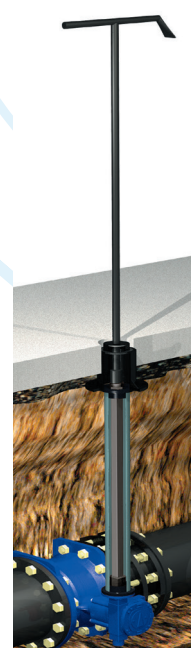

Picture 3. T-Key with extension

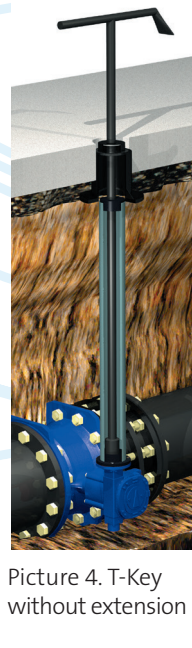

Picture 4. T-Key without extension



OPERATING ACCESSORIES

REFERENCES OF THE BURIED SERVICE VALVE OPERATED WITH T-KEY

Installation below ground extension tube 1 and 2 m (square 28x28)

1 - Extension spindle with operating cap	IRON		
- Height 1 m	RAA28 F1	-	
- Height 2 m	RAA28 F2	-	
2 - Spindle guide cover	Ductile iron	PVC	
- For protection tube	162032	162033	
3 - Protection tube	IRON (lg 1 m)	PVC (lg 1.1m)	
- For spindle h= 1m 1 tube	RAC10AB	RAC11AD	
- For spindle h= 2m 2 tubes	Ø 20 : 162051 (0.9 kg)	Ø 30 : 162086 (1.1 kg)	
4 - Operating coupling Ø 20 (F10) or Ø30 According to Valve DN			
5 - Support for protection tube	Ø 20 (F10)	Ø 30 (F14)	
- For iron or pvc tube	162030 (0.15 kg)	162029 (2.2 kg)	
6 - Intermediate support Height = 2m	IRON	PVC	
- For protection tube	RAA80DB (0.8 kg)	RAA80ED (0.1 kg)	
7 - Surface box	PAVA	Roadways	T Pathways
	8 kg H105 F1PVAC	Round FRTOAB 5 kg	Round FTTOAB 3 kg
	13 kg H185 F2PVAC	Hexagonal FRTODB 5 kg	Hexagonal FITODB 3 kg
	23 kg H150 F3PVAC	Square FRTOBB 5 kg	Square FITOBB 3 kg

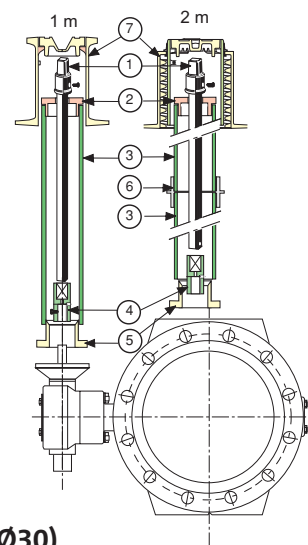

Installation below ground extension tube 3 to 6 m with tube 33/42(Ø20) or 50/60(Ø30)

1 - Handwheel		162082		
2 and 4 - Adaptor to be welded	Ø20(33/42)	Ø30(50/60)		
- Square 28	162077	163358		
3 - Extension tube	Ø20(33/42)	Ø30(50/60)		
- Length 3 m	162088	162229		
- Length 4.5 m	162231	162232		
- Length 6 m	162090	162140		
5 - Operating coupling				
6 - Spindle guide cover		Ductile Iron		
- For protection tube		162032		
7 - Protection tube	Qty	Iron lg 1.5m	Qty	PVC lg 1.1m
- For L= 3m	2	RAC15AB	3	RAC11AD
- For L= 4.5m	3	RAC15AB	4	RAC11AD
- For L= 6 m	4	RAC15AB	6	RAC11AD
8 - Intermediate Support	Qty	Ductile iron	Qty	PVC
- For L= 3m	1	RAA80DB	2	RAA80ED
- For L= 4.5m	2	RAA80DB	3	RAA80ED
- For L= 6 m	3	RAA80DB	5	RAA80ED
9 - Support protection tube	Ø20 (F10)	Ø30 (F14)		
- Ductile iron or PVC	162030	162029		
10 - Headstock without indicator		See table above		

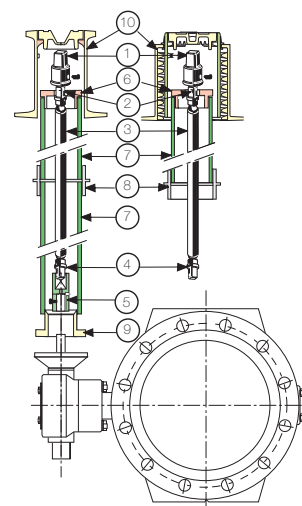

Telescopic operating unit, length 1 to 7 meters.

	DN	Ø keyed (mm)	Length and mass							
			1.10-1.50 m	1.20-1.80 m	1.35-2.00 m	1.70-2.70 m	2.60-4.50 m	3.10-5.50 m	3.40-6.00 m	3.90-7.00 m
			4.80kg	5.20kg	5.40kg	7.30kg	12kg	13.90kg	15kg	17kg
PN10	150 to 1200	20	225196	225147	225190	225191	225192	225193	225194	225195
	1400 to 1600	30	225197	225198	225199	225200	225201	225202	225203	225204
	1800	20	225196	225147	225190	225191	225192	225193	225194	225195
	2000	30	225197	225198	225199	225200	225201	225202	225203	225204
PN16	150 to 1000	20	225196	225147	225190	225191	225192	225193	225194	225195
	1200	30	225197	225198	225199	225200	225201	225202	225203	225204
	1400 to 1600	20	225196	225147	225190	225191	225192	225193	225194	225195
	1800 to 2000	30	225197	225198	225199	225200	225201	225202	225203	225204
PN25	150 to 900	20	225196	225147	225190	225191	225192	225193	225194	225195
	1000	30	225197	225198	225199	225200	225201	225202	225203	225204
	1200 to 1400	20	225196	225147	225190	225191	225192	225193	225194	225195
	1500 to 1600	30	225197	225198	225199	225200	225201	225202	225203	225204



Picture 5. Telescopic operating unit.



DN 150-2000 mm, PN 10, 16 and 25 bar

AUMA GEARBOXES

○ 1/4 TURN GEARBOXES

The basic function of this range is to decrease the input torque by means of a reduction ratio:

- With handwheel.
- GS 50.3 - GS 250.3: torques from 125 Nm to 45,000 Nm.
- GS 315 - GS 500: torques from 63,000 Nm to 360,000 Nm.

○ DESIGN PRINCIPLE

1. Pointer cover: follows the travel, continuously showing the valve position.
2. Housing: made of cast iron. It filled with lubricant which ensures optimal performance in any possible mounting position.
3. Gearing: the worm gearing enables a high reduction ratio within a single stage.
4. End stops: limit the swing angle. Only the comparatively low input torque acts on the end stops, not the high output torque. Thereby a high level of safety against damage due to overload is assured.
5. Coupling: the separate coupling enables easier mounting of the gearbox.
6. Valve mounting: according to EN ISO 5211. Different mountings are available on request.
7. Flange for mounting a multi-turn actuator: according to EN ISO 5210 (optional DIN 3210).
8. Standard enclosure protection (IP):
 - IP 68-8 for GS 50.3 to GS250.3 and
 - IP 67 for GS315 to GS 400.
 Increased enclosure protection is available on request.

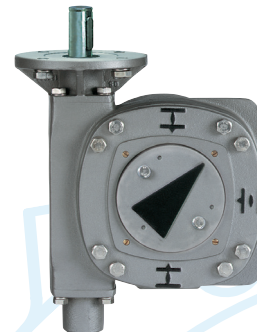

Gearbox type GS 50-100.3 with flange F10 or F14 for motorisation

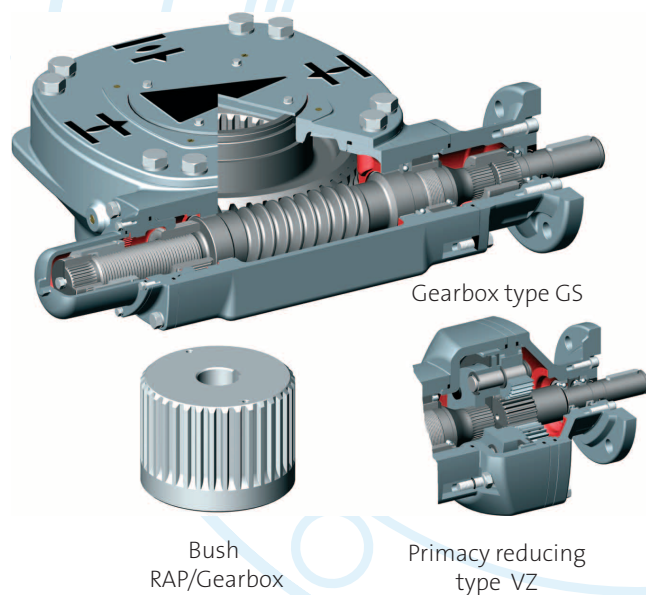

○ PRIMARY REDUCTION GEARING

Primary reduction gearing reduces the required input torques and allows the manual operation relatively large valves. It has to be verified whether the increased operating time caused by the additional reduction is acceptable.

Up to dimension GS 250.3 the primary reduction gearing is of a planetary type. For larger dimensions they are spur gears.



AUMA GEARBOXES

○ MANUAL EUROSTOP BUTTERFLY VALVE

	DN	Gearbox Auma type T ISO 5211 flange BV/Gear	Number of turns	Operating torque (Nm)	Ø stem	Valve/Gearbox connection type	Handwheel Ø (mm)
PFA 10 bar	150	GS 50.3 – F10	12.75	8	16	F10	200
	200	GS 50.3 – F10	12.75	12	16	F10	200
	250	GS 50.3 – F10	12.75	21	16	F10	200
	300	GS 50.3 – F10	12.75	30	16	F10	200
	350	GS 63.3 – F12	12.75	40	20	F12	250
	400	GS 63.3 – F12	12.75	61	20	F12	250
	450	GS 80.3 – F14	13.25	72	20	F14	250
	500	GS 80.3 – F14	13.25	92	20	F14	250
	600	GS 100.3 – F16	13	133	20	F16	350
	700	GS 100.3+VZ4.3 – F16	52	52	20	F16	350
	800	GS 125.3+VZ4.3 – F25	52	77	20	F25	350
	900	GS 125.3+VZ4.3 – F25	52	100	20	F25	350
	1000	GS 160.3+GZ160.3 – F30	110.5	65	20	F30	350
	1200	GS 200.3+GZ200.3 – F30	216	74	20	F30	350
	1400	GS 250.3+GZ250.3 – F35	212	93	20	F35	500
	1500	GS 250.3+GZ250.3 – F35	212	110	20	F35	500
	1600	GS 250.3+GZ250.3 – F35	212	130	20	F35	500
1800	GS 315+GZ30 – F40	424	75	20	F40	500	
2000	GS 315+GZ30 – F40	424	75	20	F40	800	
PFA 16 bar	150	GS 50.3 – F10	12.75	8	16	F10	200
	200	GS 50.3 – F10	12.75	17	16	F10	200
	250	GS 50.3 – F10	12.75	29	16	F10	200
	300	GS 63.3 – F12	12.75	43	20	F12	250
	350	GS 63.3 – F12	12.75	60	20	F12	250
	400	GS 80.3 – F14	13.25	84	20	F14	250
	450	GS 80.3 – F14	13.25	112	20	F14	250
	500	GS 100.3 – F14	13	125	20	F14	350
	600	GS 100.3+VZ4.3 – F16	52	59	20	F16	350
	700	GS 125.3+VZ4.3 – F25	52	84	20	F25	350
	800	GS 160.3+GZ160.3 – F30	110.5	64	20	F30	350
	900	GS 160.3+GZ160.3 – F30	110.5	83	20	F30	350
	1000	GS 200.3+GZ200.3 – F30	216	65	20	F30	350
	1200	GS 250.3+GZ250.3 – F35	212	104	20	F35	500
	1400	GS 315+GZ30 – F40	424	65	20	F40	500
	1500	GS 315+GZ30 – F40	424	77	20	F40	500
	1600	GS 315+GZ30 – F40	424	94	20	F40	500
1800	GS 400+GZ35 – F48	432	126	20	F48	800	
2000	GS 400+GZ35 – F48	432	161	20	F48	800	
PFA 25 bar	150	GS 50.3 – F10	12.75	13	16	F10	200
	200	GS 50.3 – F10	12.75	28	16	F10	200
	250	GS 63.3 – F12	12.75	45	20	F12	250
	300	GS 63.3 – F12	12.75	71	20	F12	250
	350	GS 80.3 – F14	13.25	89	20	F14	250
	400	GS 100.3 – F14	13	122	20	F14	350
	450	GS 100.3+VZ4.3 – F16	52	45	20	F16	350
	500	GS 100.3+VZ4.3 – F16	52	59	20	F16	350
	600	GS 125.3+VZ4.3 – F25	52	100	20	F25	350
	700	GS 160.3+GZ160.3 – F30	110.5	70	20	F30	350
	800	GS 200.3+GZ200.3 – F30	216	65	20	F30	350
	900	GS 200.3+GZ200.3 – F35	216	84	20	F35	350
	1000	GS 250.3+GZ250.3 – F35	212	115	20	F35	500
	1200	GS 315+GZ30 – F40	424	74	20	F40	500
	1400	GS 315+GZ30 – F40	424	110	20	F40	500
	1500	GS 400+GZ35 – F48	432	133	20	F48	800
	1600	GS 400+GZ35 – F48	432	153	20	F48	800

The data given in these tables may be modified without prior notice



DN 150-2000 mm, PN 10, 16 and 25 bar

AUMA GEARBOXES

○ MOTORISABLE OR MOTORISED EUROSTOP BUTTERFLY VALVE

	DN	Gearbox Auma type T ISO 5211 flange BV/Gear	Number of turns	Operating torque (Nm)	Valve/Gearbox connection type	Dim	Drilling (mm)	Number of bolts	Handwheel Ø (mm)
PFA 10 bar	150	GS 50.3 – F10	12.75	8	F10	102	M10	4	200
	200	GS 50.3 – F10	12.75	12	F10	102	M10	4	200
	250	GS 50.3 – F10	12.75	21	F10	102	M10	4	200
	300	GS 50.3 – F10	12.75	30	F10	102	M10	4	200
	350	GS 63.3 – F12	12.75	39	F12	125	M12	4	250
	400	GS 63.3 – F12	12.75	60	F12	125	M12	4	250
	450	GS 80.3 – F14	13.25	70	F14	140	M16	4	250
	500	GS 80.3 – F14	13.25	90	F14	140	M16	4	250
	600	GS 100.3+VZ4.3 – F16	52	35	F16	165	M20	4	350
	700	GS 100.3+VZ4.3 – F16	52	52	F16	165	M20	4	350
	800	GS 125.3+VZ4.3 – F25	52	77	F25	254	M16	8	350
	900	GS 160.3+GZ160.3 – F25	110.5	47	F25	254	M16	8	350
	1000	GS 160.3+GZ160.3 – F30	110.5	65	F30	298	M20	8	350
	1200	GS 200.3+GZ200.3 – F30	216	60	F30	298	M20	8	350
	1400	GS 250.3+GZ250.3 – F35	212	93	F35	356	M30	8	500
	1500	GS 250.3+GZ250.3 – F35	212	110	F35	356	M30	8	500
	1600	GS 250.3+GZ250.3 – F35	212	130	F35	356	M30	8	500
1800	GS 315+GZ30 – F40	424	75	F40	406	M36	8	500	
2000	GS 315+GZ30 – F40	424	117	F40	406	M36	8	500	
PFA 16 bar	150	GS 50.3 – F10	12.75	8	F10	102	M10	4	200
	200	GS 50.3 – F10	12.75	17	F10	102	M10	4	200
	250	GS 50.3 – F10	12.75	29	F10	102	M10	4	200
	300	GS 63.3 – F12	12.75	42	F12	125	M12	4	250
	350	GS 63.3 – F12	12.75	59	F12	125	M12	4	250
	400	GS 80.3 – F14	13.25	83	F14	140	M16	4	250
	450	GS 100.3+VZ4.3 – F14	52	26	F14	140	M16	4	250
	500	GS 100.3+VZ4.3 – F14	52	33	F14	140	M16	4	350
	600	GS 100.3+VZ4.3 – F16	52	59	F16	165	M20	4	350
	700	GS 125.3+VZ4.3 – F25	52	84	F25	254	M16	8	350
	800	GS 160.3+GZ160.3 – F30	110.5	64	F30	298	M20	8	350
	900	GS 160.3+GZ160.3 – F30	110.5	83	F30	298	M20	8	350
	1000	GS 200.3+GZ200.3 – F30	216	65	F30	298	M20	8	350
	1200	GS 250.3+GZ250.3 – F35	212	104	F35	356	M30	8	500
	1400	GS 315+GZ30 – F40	424	65	F40	406	M36	8	500
	1500	GS 315+GZ30 – F40	424	77	F40	406	M36	8	500
	1600	GS 315+GZ30 – F40	424	94	F40	406	M36	8	500
1800	GS 400+GZ35 – F48	432	126	F48	483	M36	12	800	
2000	GS 400+GZ35 – F48	432	161	F48	483	M36	12	800	
PFA 25 bar	150	GS 50.3 – F10	12.75	13	F10	102	M10	4	200
	200	GS 50.3 – F10	12.75	28	F10	102	M10	4	200
	250	GS 63.3 – F12	12.75	45	F12	125	M12	4	250
	300	GS 63.3 – F12	12.75	71	F12	125	M12	4	250
	350	GS 80.3 – F14	13.25	88	F12	140	M16	4	250
	400	GS 100.3+VZ4.3 – F14	52	32	F14	140	M16	4	350
	450	GS 100.3+VZ4.3 – F16	52	43	F16	140	M16	4	350
	500	GS 100.3+VZ4.3 – F16	52	59	F16	165	M20	4	350
	600	GS 160.3+GZ160.3 – F25	110.5	47	F25	254	M16	8	350
	700	GS 160.3+GZ160.3 – F30	110.5	70	F30	298	M20	8	350
	800	GS 200.3+GZ200.3 – F30	216	65	F30	298	M20	8	350
	900	GS 200.3+GZ200.3 – F35	216	84	F35	356	M30	8	350
	1000	GS 250.3+GZ250.3 – F35	212	115	F35	356	M30	8	500
	1200	GS 315+GZ30 – F40	424	74	F40	406	M36	8	500
	1400	GS 315+GZ30 – F40	424	110	F40	406	M36	8	500
	1500	GS 400+GZ35 – F48	432	133	F48	483	M36	12	800
	1600	GS 400+GZ35 – F48	432	153	F48	483	M36	12	800

The data given in these tables may be modified without prior notice



AUMA GEARBOXES

○ BURIED SERVICE EUROSTOP BUTTERFLY VALVE

	DN	Gearbox Auma type T ISO 5211 flange BV/Gear	Number of turns	Operating torque (Nm)	Valve/Gearbox connection type	Dim	Drilling (mm)	Number of bolts
PFA 10 bar	150	GS 63.3 – F10	12.75	8	F10	102	M10	4
	200	GS 63.3 – F10	12.75	13	F10	102	M10	4
	250	GS 63.3 – F10	12.75	21	F10	102	M10	4
	300	GS 63.3 – F10	12.75	31	F10	102	M10	4
	350	GS 63.3 – F12	12.75	40	F12	125	M12	4
	400	GS 63.3 – F12	12.75	61	F12	125	M12	4
	450	GS 80.3 – F14	13.25	79	F14	140	M16	4
	500	GS 80.3 – F14	13.25	101	F14	140	M16	4
	600	GS 100.3 – F16	13	133	F16	165	M20	4
	700	GS 100.3+VZ4.3 – F16	52	52	F16	165	M20	4
	800	GS 125.3+VZ4.3 – F25	52	77	F25	254	M16	8
	900	GS 125.3+VZ4.3 – F25	52	100	F25	254	M16	8
	1000	GS 160.3+GZ160.3 – F30	110.5	65	F30	298	M20	8
	1200	GS 200.3+GZ200.3 – F30	216	74	F30	298	M20	8
	1400	GS 250.3+GZ250.3 – F35	212	93	F35	356	M30	8
	1500	GS 250.3+GZ250.3 – F35	212	110	F35	356	M30	8
1600	GS 250.3+GZ250.3 – F35	212	130	F35	356	M30	8	
1800	GS 315+GZ30 – F40	424	75	F40	406	M36	8	
2000	GS 400+GZ35 – F48	432	117	F48	483	M36	12	
PFA 16 bar	150	GS 63.3 – F10	12.75	8	F10	102	M10	4
	200	GS 63.3 – F10	12.75	17	F10	102	M10	4
	250	GS 63.3 – F10	12.75	30	F10	102	M10	4
	300	GS 63.3 – F12	12.75	43	F12	125	M12	4
	350	GS 63.3 – F12	12.75	60	F12	125	M12	4
	400	GS 80.3 – F14	13.25	93	F14	140	M16	4
	450	GS 80.3 – F14	13.25	112	F14	140	M16	4
	500	GS 100.3 – F14	13	125	F14	140	M16	4
	600	GS 100.3+VZ4.3 – F16	52	59	F16	165	M20	4
	700	GS 125.3+VZ4.3 – F25	52	84	F25	254	M16	8
	800	GS 160.3+GZ160.3 – F30	110.5	64	F30	298	M20	8
	900	GS 160.3+GZ160.3 – F30	110.5	83	F30	298	M20	8
	1000	GS 200.3+GZ200.3 – F30	216	65	F30	298	M20	8
	1200	GS 250.3+GZ250.3 – F35	212	104	F35	356	M30	8
	1400	GS 315+GZ30 – F40	424	65	F40	406	M36	8
	1500	GS 315+GZ30 – F40	424	77	F40	406	M36	8
1600	GS 315+GZ30 – F40	424	94	F40	406	M36	8	
1800	GS 400+GZ35 – F48	432	126	F48	483	M36	12	
2000	GS 400+GZ35 – F48	432	161	F48	483	M36	12	
PFA 25 bar	150	GS 63.3 – F10	12.75	13	F10	102	M10	4
	200	GS 63.3 – F10	12.75	29	F10	102	M10	4
	250	GS 63.3 – F12	12.75	45	F12	125	M12	4
	300	GS 63.3 – F12	12.75	71	F12	125	M12	4
	350	GS 80.3 – F14	13.25	98	F14	140	M16	4
	400	GS 100.3 – F14	13	122	F14	140	M16	4
	450	GS 100.3+VZ4.3 – F16	52	45	F16	165	M20	4
	500	GS 100.3+VZ4.3 – F16	52	59	F16	165	M20	4
	600	GS 125.3+VZ4.3 – F25	52	100	F25	254	M16	8
	700	GS 160.3+GZ160.3 – F30	110.5	70	F30	298	M20	8
	800	GS 200.3+GZ200.3 – F30	216	65	F30	298	M20	8
	900	GS 200.3+GZ200.3 – F35	216	84	F35	356	M30	8
	1000	GS 250.3+GZ250.3 – F35	212	115	F35	356	M30	8
	1200	GS 315+GZ30 – F40	424	74	F40	406	M36	8
	1400	GS 315+GZ30 – F40	424	110	F40	406	M36	8
	1500	GS 400+GZ35 – F48	432	133	F48	483	M36	12
1600	GS 400+GZ35 – F48	432	153	F48	483	M36	12	

The data given in these tables may be modified without prior notice



DN 150-2000 mm, PN 10, 16 and 25 bar

AUMA ACTUATORS

○ MULTI - TURN ACTUATORS SA

The range determined by torque and output speed. For the EUROSTOP butterfly valve we use SA 07.6 – SA 14.2: torque from 60 to 250 Nm. Output speed from 4 to 90 rpm.

○ DESIGN PRINCIPLE

1. Motor: actuators are generally supplied with 3-phase motors. The actuators can also be equipped with DC or single-phase motors.
2. Control unit: according to the type of valve, the actuator can be switched off via limit switches or torque seating. The switches inform the control unit when the set switching points are reached and the motor is stopped.
3. Gearing: worm gearing, sometimes combined with a planetary gear, is used to reduce the motor speed to the required actuator output speed. This system ensures irreversibility.
4. Valve mounting: according to EN ISO 5210.
5. Manual operation: for commissioning or in an emergency. Automatically disengaged when the motor is started.
6. Electrical connection: The connections are made by using a plug/socket connector. As a result, the correct wiring remains undisturbed if the actuator is removed from the valve for maintenance.

Integral controls (option): Normally, the actuator is not equipped with an integrated control. As an option, the actuator can be equipped with Aumatic or Auma Matic integral control, in order to be operated locally or remotely.

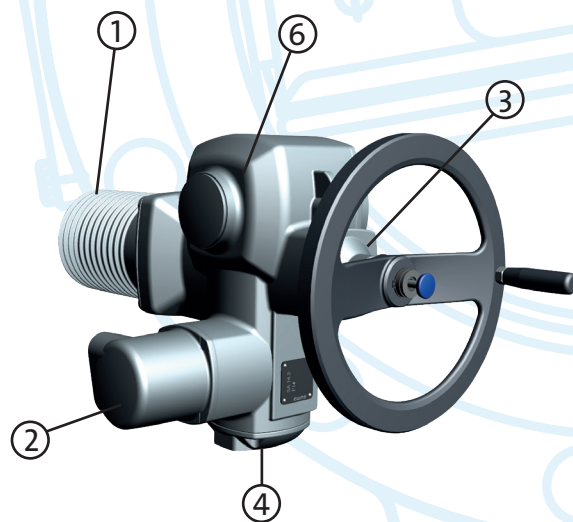



AUMA ACTUATORS

MOTORISED BUTTERFLY VALVE

DN	Gearbox ISO 5211		Actuator ISO 5210					
	Type	No. of turns	Type	Operating torque (Nm)	Speed (rpm)	Operating time		
						DN/5	Real	
PFA 10 bar	150	GS 50.3 – F10	12.75	SA 07.6	8	22	30	35
	200	GS 50.3 – F10	12.75	SA 07.6	12	22	40	35
	250	GS 50.3 – F10	12.75	SA 07.6	21	16	50	48
	300	GS 50.3 – F10	12.75	SA 07.6	31	16	60	48
	350	GS 63.3 – F12	12.75	SA 07.6	40	11	70	70
	400	GS 63.3 – F12	12.75	SA 10.2	61	11	80	72
	450	GS 80.3 – F14	13.25	SA 10.2	18	32	90	98
	500	GS 80.3 – F14	13.25	SA 10.2	23	32	100	98
	600	GS 100.3+VZ4.3 – F16	52	SA 07.6	35	32	120	98
	700	GS 100.3+VZ4.3 – F16	52	SA 10.2	51	22	140	142
	800	GS 125.3+VZ4.3 – F25	52	SA 10.2	77	22	160	142
	900	GS 160.3+GZ160.3 – F25	110.5	SA 10.2	47	32	180	207
	1000	GS 160.3+GZ160.3 – F30	110.5	SA 10.2	65	32	200	207
	1200	GS 200.3+GZ200.3 – F30	216	SA 10.2	74	63	240	206
	1400	GS 250.3+GZ250.3 – F35	212	SA 14.2	93	45	280	283
	1500	GS 250.3+GZ250.3 – F35	212	SA 14.2	110	45	300	283
	1600	GS 250.3+GZ250.3 – F35	212	SA 14.2	130	45	320	283
	1800	GS 315+GZ30 – F40	424	SA 10.2	75	63	360	404
2000	GS 315+GZ30 – F40	432	SA 14.2	117	63	400	411	
PFA 16 bar	150	GS 50.3 – F10	12.75	SA 07.6	8	22	30	35
	200	GS 50.3 – F10	12.75	SA 07.6	17	22	40	35
	250	GS 50.3 – F10	12.75	SA 07.6	30	16	50	48
	300	GS 63.3 – F12	12.75	SA 07.6	43	16	60	48
	350	GS 63.3 – F12	12.75	SA 10.2	60	11	70	72
	400	GS 80.3 – F14	13.25	SA 10.2	21	45	80	69
	450	GS 100.3+VZ4.3 – F14	52	SA 07.6	26	32	90	98
	500	GS 100.3+VZ4.3 – F14	52	SA 07.6	33	32	100	98
	600	GS 100.3+VZ4.3 – F16	52	SA 10.2	57	22	120	142
	700	GS 125.3+VZ4.3 – F25	52	SA 10.2	39	45	140	147
	800	GS 160.3+GZ160.3 – F30	110.5	SA 10.2	64	45	160	147
	900	GS 200.3+GZ200.3 – F30	216	SA 10.2	48	63	180	206
	1000	GS 200.3+GZ200.3 – F30	216	SA 10.2	65	63	200	206
	1200	GS 250.3+GZ250.3 – F35	212	SA 14.2	104	63	240	202
	1400	GS 315+GZ30 – F40	424	SA 10.2	65	90	280	283
	1500	GS 315+GZ30 – F40	424	SA 10.2	77	90	300	283
	1600	GS 315+GZ30 – F40	424	SA 14.2	94	90	320	283
	1800	GS 400+GZ35 – F48	432	SA 14.2	126	63	360	411
2000	GS 400+GZ35 – F48	432	SA 14.2	161	63	400	411	
PFA 25 bar	150	GS 50.3 – F10	12.75	SA 07.6	13	22	30	35
	200	GS 50.3 – F10	12.75	SA 07.6	29	22	40	35
	250	GS 63.3 – F12	12.75	SA 07.6	45	16	50	48
	300	GS 63.3 – F12	12.75	SA 10.2	71	16	60	50
	350	GS 80.3 – F14	13.25	SA 10.2	23	45	70	69
	400	GS 100.3+VZ4.3 – F14	52	SA 07.6	32	45	80	69
	450	GS 100.3+VZ4.3 – F16	52	SA 07.6	43	32	90	98
	500	GS 100.3+VZ4.3 – F16	52	SA 10.2	57	32	100	98
	600	GS 160.3+GZ160.3 – F25	110.5	SA 10.2	47	45	120	147
	700	GS 160.3+GZ160.3 – F30	110.5	SA 10.2	70	45	140	147
	800	GS 200.3+GZ200.3 – F30	216	SA 10.2	65	90	160	144
	900	GS 200.3+GZ200.3 – F35	216	SA 10.2	84	63	180	206
	1000	GS 250.3+GZ250.3 – F35	212	SA 14.2	115	63	200	202
	1200	GS 315+GZ30 – F40	424	SA 10.2	74	90	240	283
	1400	GS 315+GZ30 – F40	424	SA 14.2	110	90	280	283
	1500	GS 400+GZ35 – F48	432	SA 14.2	133	90	300	288
	1600	GS 400+GZ35 – F48	432	SA 14.2	153	90	320	288

The data given in these tables may be modified without prior notice



DN 150-2000 mm, PN 10, 16 and 25 bar

SAFETY BUTTERFLY VALVES WITH COUNTERWEIGHT

GENERAL INFORMATION

- Safety butterfly valves protect the network in case of accidental rupture of a pipeline automatically isolating fluid flow.
- In the event of high velocity of water the butterfly valve closes automatically.
- Safety valves are used to protect networks of hydroelectric power schemes, irrigation and water supply systems being installed near the upstream reservoir, on the entries to plants, towns, rural areas, etc.
- In the event of electric power failure, safety valves shut off pipeline preventing emptying of the network.
- Protection of turbine equipment in the event of fluid over speed.
- Prevents flooding in the case of a pipe breakage in the network so protecting sensitive risk zones such as motorways, railways etc.



DN	PN 10		PN 16		PN 25	
	Weight kg	Reference	Weight kg	Reference	Weight kg	Reference
150	237	203570	237	203570		consult us
200	250	226232	250	203581	265	203584
250	273	203586		consult us		consult us
300	293	203593	407	203596	440	203599
350	429	203601		consult us		consult us
400	463	203605	650	203612	679	203614
450	650	203617	690	203621		consult us
500	679	203622	729	203629	993	203634
600	948	203638	1030	203641	1577	203646
700	1103	203648	1616	203656	2588	203658
800	1721	203661	2657	203673		consult us
900	1917	203676	2828	203682	4196	203685
1000	3037	203686	3187	203693		consult us
1200	3478	203696	4937	203703		consult us
1400	5092	203705	7358	215382	9158	203709

For DN > 1400, please consult us.

CONSTRUCTION SPECIFICATIONS

UNIT CONSISTS:

- The valve is operated by the counterweight and the oleohydraulic cylinder.
- Mechanical-hydraulic type of the over speed detector.
- Electric or manual oleohydraulic system for opening/closing of the disc.

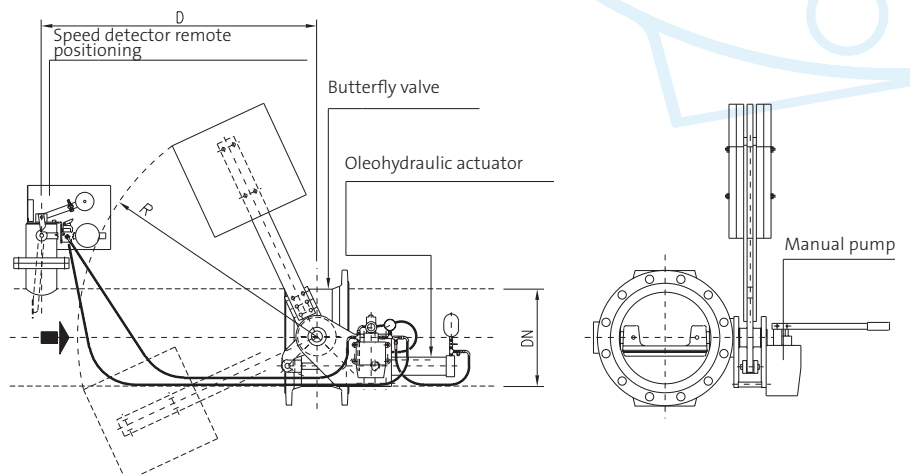



SAFETY BUTTERFLY VALVES WITH COUNTERWEIGHT

○ VALVE

We are referring to a standard EUROSTOP butterfly valve which has as an actuator:

- An oleohydraulic cylinder to maintain the valve open.
- A counterweight dimensioned to ensure self-closing of the butterfly valve in extreme situations.

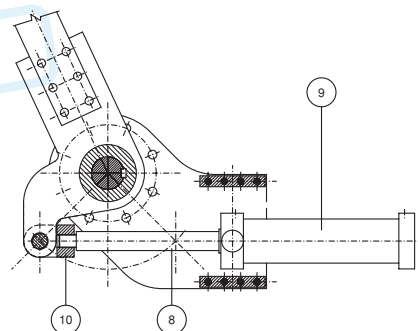

N°	Description	Materials
1	Body connection	Steel Fe 360 B
2	External slab	Steel Fe 360 B
3	Connection slab	Steel Fe 360 B
4	Lever	Steel Fe 360 B
5	Cover	Steel Fe 360 B
6	Shaft bush	Bronze
7	Cylinder bush	Bronze
8	Cylinder piston	Steel C40
9	Jack body	ATOS SERIE CK
10	Piston joint	Steel C40

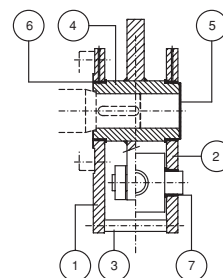

○ OVER SPEED DETECTOR

- Mechanic/hydraulic in the absence of power supply.
- Magnetic/inductive or ultrasound otherwise.
- Safety intervention speed can be modified from 0.5 to 3 m/s.

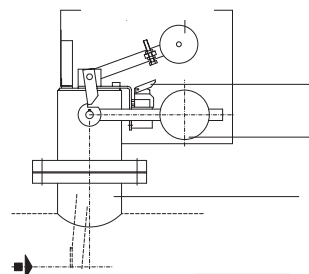

○ OLEOHYDRAULIC SYSTEM

- The oleohydraulic valve of the speed detector opens when the scoop moves due to over speed and allows evacuating of oil from the cylinder which closes the butterfly valve.
- Closing speed is checked by the control valve.
- The butterfly valve is reopened with the manual pump.

1. Oleodynamic cylinder	5. Speed detector
2. Manual pump	6. Manometer
3. Check valve	7. Accumulator
4. Control valve	8. Ball valve

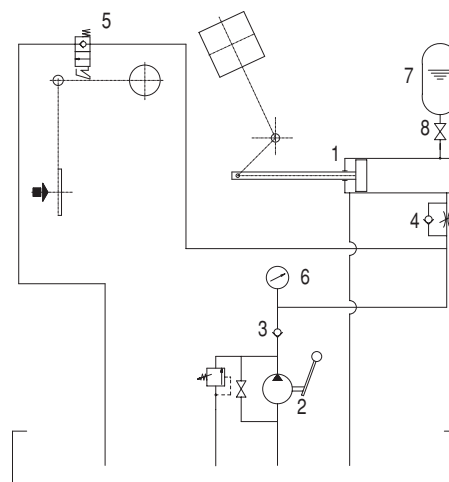

DISMANTLING JOINTS

PO and JP TYPES TABLE OF DIMENSIONS

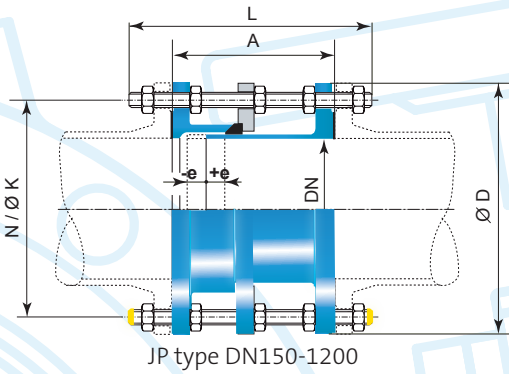

JP type DN150-1200

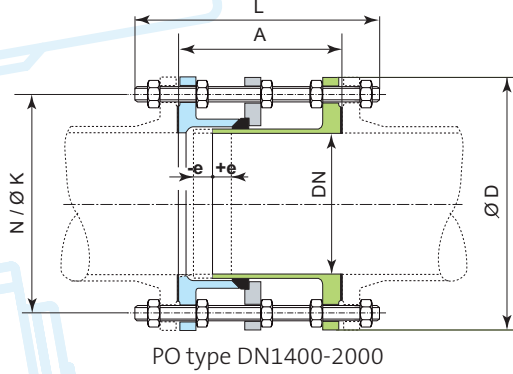

PO type DN1400-2000

PFA
10 bar

PFA
16 bar

PFA
25 bar

	DN	A	øD	øK	TIE BARS			A	øD	øK	TIE BARS			A	øD	øK	TIE BARS		
					N	M	L				N	M	L				N	M	L
Type «JP»	150	200	285	240	8	M20	330	200	285	240	8	M20	330	240	300	250	8	M24	400
	200	280	340	295	8	M20	430	280	340	295	12	M20	430	280	360	310	12	M24	450
	250	280	395	350	12	M20	430	280	405	355	12	M24	450	280	425	370	12	M27	450
	300	280	445	400	12	M20	430	280	460	410	12	M24	450	280	485	430	16	M27	450
	350	280	505	460	16	M20	430	280	520	470	16	M24	450	320	555	490	16	M30	503
	400	280	565	515	16	M24	450	280	580	525	16	M27	450	320	620	550	16	M33	530
	450	330	615	565	20	M24	530	330	640	585	20	M27	550	350	670	600	20	M33	580
	500	330	670	620	20	M24	530	330	715	650	20	M30	550	350	730	660	20	M33	580
	600	330	780	725	20	M27	550	330	840	770	20	M33	550	380	845	770	20	M36	620
	700	330	895	840	24	M27	550	330	910	840	24	M33	550	400	960	875	24	M39	660
	800	400	1015	950	24	M30	650	400	1025	950	24	M36	670	410	1085	990	24	M45	700
	900	400	1115	1050	28	M30	650	400	1125	1050	28	M36	670	420	1185	1090	28	M45	700
1000	400	1230	1160	28	M33	650	400	1255	1170	28	M39	670	440	1320	1210	28	M52	750	
1100	450	1330	1270	28	M36	730	450	1370	1280	32	M39	750	440	1420	1310	32	M52	750	
1200	450	1455	1380	32	M36	730	450	1485	1390	32	M45	750	450	1530	1420	32	M52	750	
Type «PO»	1400	360	1675	1590	36	M39	590	380	1685	1590	36	M45	660	500	1755	1640	36	M56	830
	1500	380	1785	1700	36	M39	615	400	1820	1710	36	M52	695	500	1865	1750	36	M56	835
	1600	390	1915	1820	40	M45	645	420	1930	1820	40	M52	720	510	1975	1860	40	M56	860
	1800	410	2115	2020	44	M45	675	420	2130	2020	44	M52	730	550	2195	2070	44	M64	920
	2000	410	2325	2230	48	M45	675	450	2345	2230	48	M56	780	600	2425	2300	48	M64	975

The data given in these tables may be modified without prior notice

○ INSTALLATION

Loosen the nuts A evenly in a diametrically opposed sequence in order to release the metal flange that presses the gasket.

To reduce the length:

Loosen the nuts B to the desired length. Slide the flanged spigot into the joint assembly. Tighten the nuts A evenly in a diametrically opposed sequence.

To extend the length:

Slide the flanged spigot out of the joint assembly. Tighten the nuts A evenly in a diametrically opposed sequence. Do the same with the nuts B.

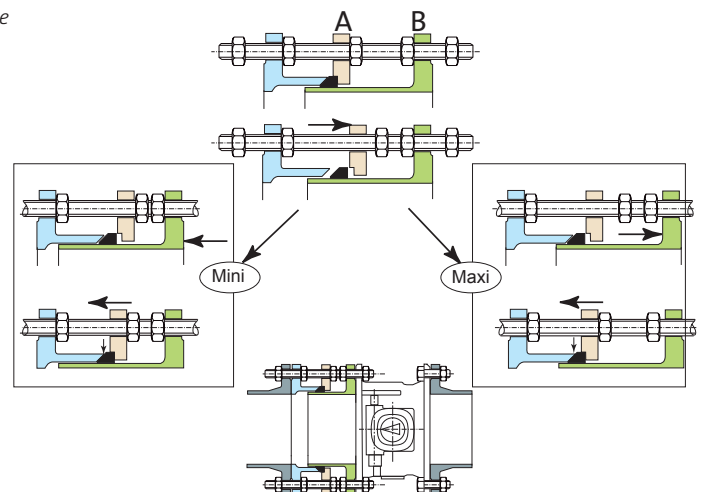



DN 150-2000 mm, PN 10, 16 and 25 bar

DISMANTLING JOINTS

« JP » and « PO » TYPE TABLE OF MASS AND REFERENCES

PFA
10 bar

PFA
16 bar

PFA
25 bar

	DN	Weight	Reference	+e	-e	Weight	Reference	+e	-e	Weight	Reference	+e	-e
Type «JP»	150	37	183214	30	30	37	183214	30	30	48	206516	30	30
	200	53	183783	40	40	60	183627	40	40	73	184600	40	40
	250	72	206550	40	40	84	183628	40	40	102	205292	40	40
	300	81	184220	40	40	99	183640	40	40	142	184611	40	40
	350	109	206677	40	40	143	183682	40	40	191	185346	40	40
	400	150	206678	40	40	170	183634	40	40	245	206517	40	40
	450	180	206679	50	50	187	206546	50	50	272	206518	40	40
	500	206	206680	50	50	276	183702	50	50	347	198572	40	40
	600	264	184918	50	50	395	183626	50	50	476	183856	50	50
	700	329	210092	50	50	428	198954	50	50	627	236291	50	50
	800	454	210082	60	60	565	184075	60	60	908	216741	50	50
	900	537	236294	60	60	663	219967	60	60	1220	207134	50	50
1000	674	236295	60	60	887	236296	60	60	1374	218303	50	50	
1100	810	236297	70	70	932	236298	70	70	1517	236299	50	50	
1200	947	236301	70	70	1447	184329	70	70	1720	236302	50	50	
Type «PO»	1400	925	MDC14DABH	25	25	1202	MDC14DAAH	25	25	2580	163600	25	25
	1500	1135	MDC15DABH	25	25	1525	MDC15DAAH	25	25	2805	MDC15DADH	25	25
	1600	1350	MDC16DABH	25	25	1791	MDC16DAAH	25	25	3132	MDC16DADH	25	25
	1800	1710	MDC18DABH	25	25	2118	MDC18DAAH	25	25	3850	MDC18DADH	25	25
	2000	2100	MDC20DABH	25	25	2990	MDC20DAAH	25	25	4560	MDC20DADH	25	25

The data given in these tables may be modified without prior notice.

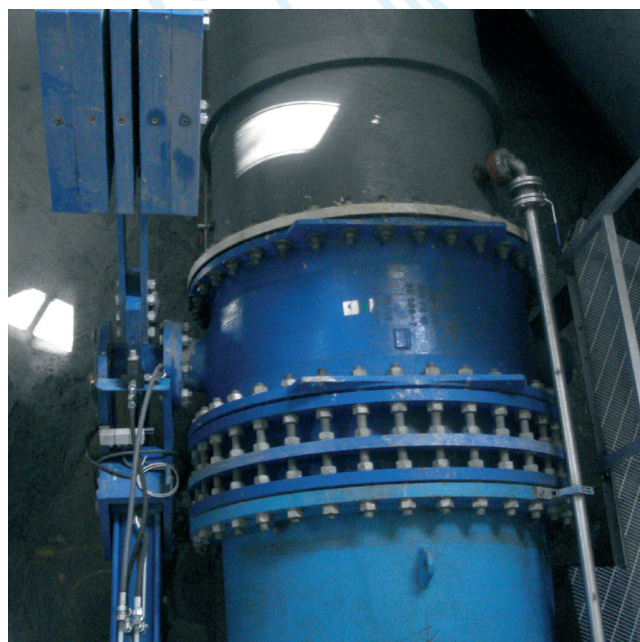



PAMKIT

○ The Pamkit service.

PAMKIT is a fully optimised product offering design and logistic benefits for the manufacture of all types of valve chambers for ductile cast iron drinking water supply networks.

Its unique presentation as a pack provides a targeted solution to realize the specific network functions: venting, isolating, washer out and turn out.

Designed to meet your needs, PAMKIT is a reference solution for your technical and logistic requirements.

Venting :

The VENTING feature on a network allows:

- when operating the network, evacuation of air in small quantities, at low flow rate ;
- when filling the pipeline with water, evacuation of air in large quantities, at high flow rate ;
- when draining the pipeline, air intake into the pipeline in large quantities, at high flow rate.

Automatic push in socket tee. Fusion bonded epoxy coating. Combination air valve for installation in a simplified valve chamber. DN 150 to 1200, PFA 10 and 16 pipeline. Please consult us for larger DN.

Isolation :

The ISOLATION feature on a network allows:

- interruption of the water flow in the pipeline, to carry out network maintenance or extension work ;
- shut-off in line ;
- shut-off in line combined with shut-off in branch.

Automatic push in socket, level invert branch TEE. Fusion bonded epoxy coating. Drainage units for installation in an embankment or in a simplified valve chamber. DN 150 to 1200, PFA 10 and 16 pipeline. Please consult us for larger DN.

Wash out :

The WASH OUT feature on a network allows:

- complete evacuation of the water from the pipeline, (air intake through the air valve) to carry out network maintenance or extension work.

Double flanges stop valve and fitting units for installation in a complete valve chamber. Fusion bonded epoxy coating. DN 150 to 1200, PFA 10 and 16 pipeline. Please consult us for larger DN.

Turn out :

The TURN OUT feature on a network allows:

- an efficient operating and maintenance, combines sectioning of the main and the branch in the same chamber.
- Flange TEE, 2 stop valves, double flange type and fitting units for installation in a complete valve chamber. Fusion bonded epoxy coating.

DN 150 to 1200, PFA 10 and 16. Please consult us for larger DN.

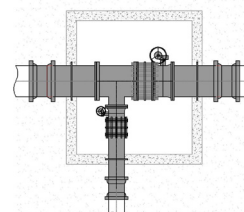
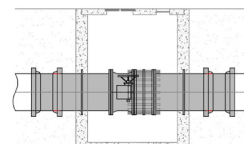
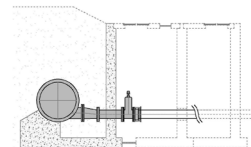
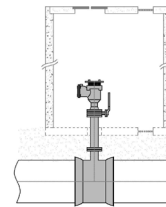

HOW TO CONTACT PAM

AUSTRIA

Saint-Gobain Rigips AUSTRIA GesmbH
Vertriebsbüro PAM
Archenweg 52
6020 Innsbruck
Tel: + 43 512 34 17 17 -0

BELGIUM

Saint-Gobain PAM BELGIUM
Raathovenstraat, n°2
3400 – LANDEN
Tel: + 32 11 88 01 00

FINLAND

Saint-Gobain PAM FINLAND
Strömberginkuja 2
00380 HELSINKI
Tel: +358 207 424 600

GREECE

Saint-Gobain HELLAS
5 KLEISOURAS STR,
14452 METAMORGOSI ,ATHENS GREECE
Tel: +30 210 2831804

NORWAY

Saint-Gobain BYGGEVARER
Nils Hansens vei 13,
0667 OSLO
Tel: + 47 23 17 58 60

THE NETHERLANDS

Saint-Gobain PAM Netherlands
Markerkant 10-17
1316 AB ALMERE
Tel: + 31 36 53 333 44

POLAND

Saint-Gobain Construction Products POLSKA SP Z O.O.
Ul. Cybernetyki 9
PL - 02-677 WARSZAWA
Tel: + 48 22 751 41 72

PORTUGAL

Saint-Gobain PAM PORTUGAL, S.A.
Rua das Marinhas do Tejo , n° 15
2690-361 SANTA IRIA DE AZÓIA
Tel: + 351 218 925 000

CZECH REPUBLIC

Saint-Gobain PAM CZ
Budova DOCK II,
Smrčkova ulice,
Praha 8 – Libeň
Tel: + 420 311 712 611

ROMANIA

Saint-Gobain Construction Products Romania S.r.l.
SGCPRo SRL
Soseaua Pipera nr.43, Cladirea Floreasca Park,
corpul A, etajul 3, birourile 25-41, cod 014254,
sector 2, Bucuresti, Romania
Tel: + 40 21 207 57 29

SLOVAKIA

Saint-Gobain Construction Products, s.r.o.
Dlha 1780/6
90031 Stupava
Tel: +421 (0) 2 654 569 61

Enquiries from other EU and overseas countries:
please consult Saint-Gobain PAM Canalisation



**Saint-Gobain PAM Canalisation •
Head office**

21, avenue Camille Cavallier
54705 Pont-à-Mousson Cedex • FRANCE
Phone : +33 (0) 383 807 350
www.pamline.com