

INSTALLATION

According to NF S 62-200 Standard August 2009

Installation in the ground.

In particular cases (installation near a manhole cover, or a chimney to visit the sewage network), please refer to NF S 62-200 Standard (page 11).

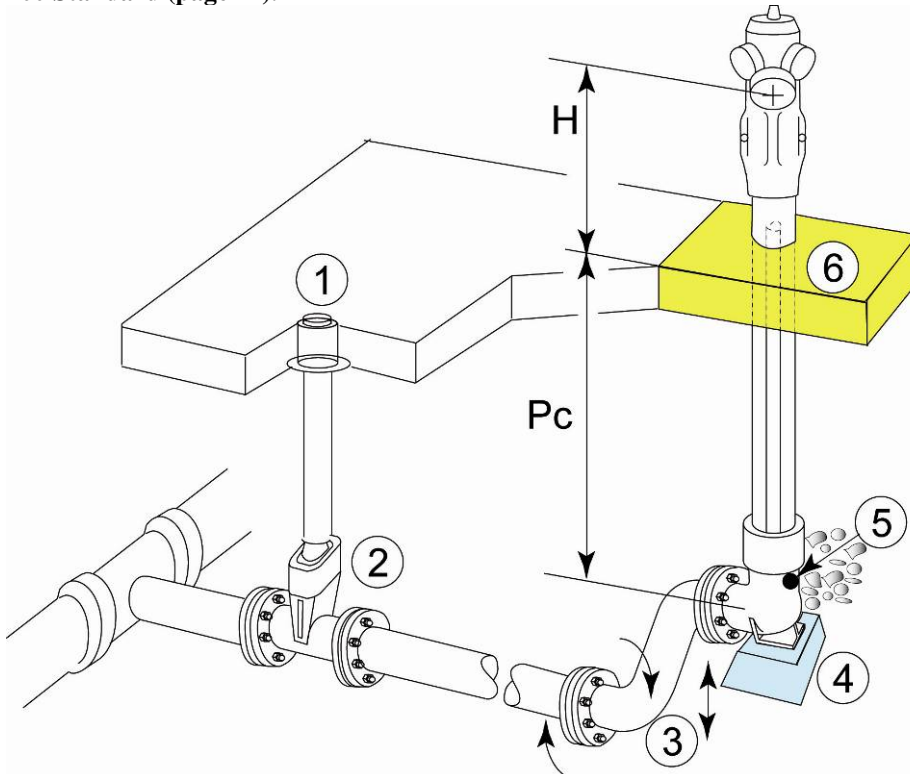

1-Surface box

2-Gate valve Euro 20

3-“S” height adjustment bend to adjust the level of the hydrant

4-Concrete block : don't obstruct the drain orifice

5- Drain orifice : draining material to be provided

6-Anchorage concrete block at ground level

20 x 20 x thickness 30cm

Installation dimensions

	Pc ±10	H
DN 80 and 100	1063	400 – 500
	1300	
Dimensions in mm.		

Volume of release: refer to Standard NF S 62-200 August 2009.

Positioning

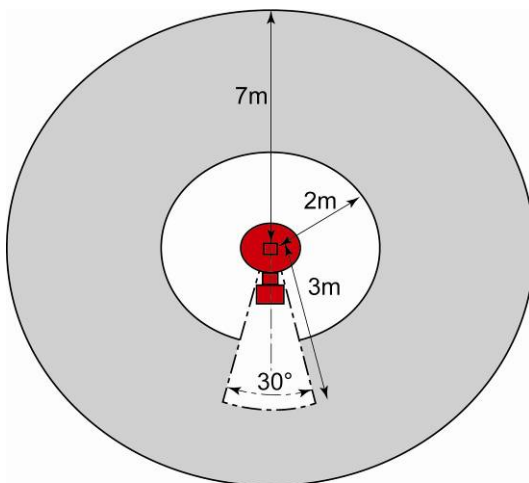

Position of the surface box for a fire hydrant with one outlet

■ defined area to instal the surface box of the isolating system

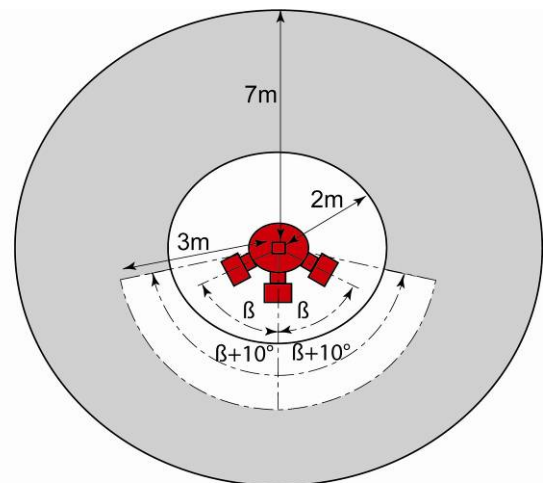

Position of the surface box for a fire hydrant with several outlets

INSTALLATION

According to NF S 62-200 Standard August 2009

Cleaning base for installation in natural ground (absence of concrete or bituminous coating) : thickness mini 15 cm.

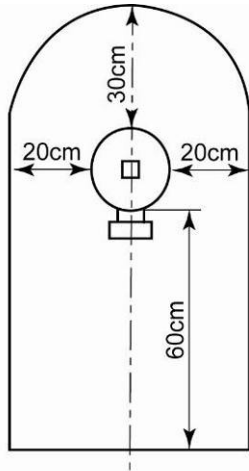

Cleaning base for fire hydrant with one outlet

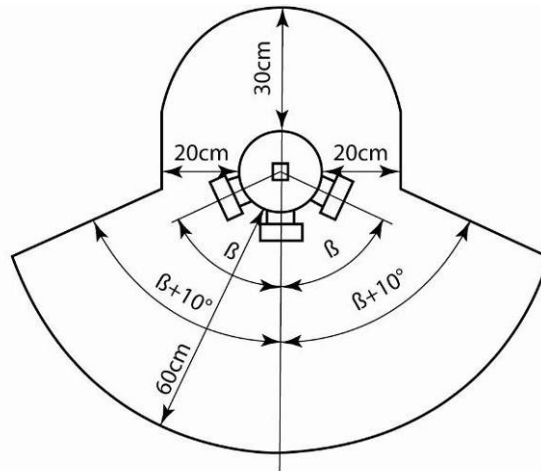

Cleaning base for fire hydrant with several outlets

Orientation of the hydrant from 0 to 360°

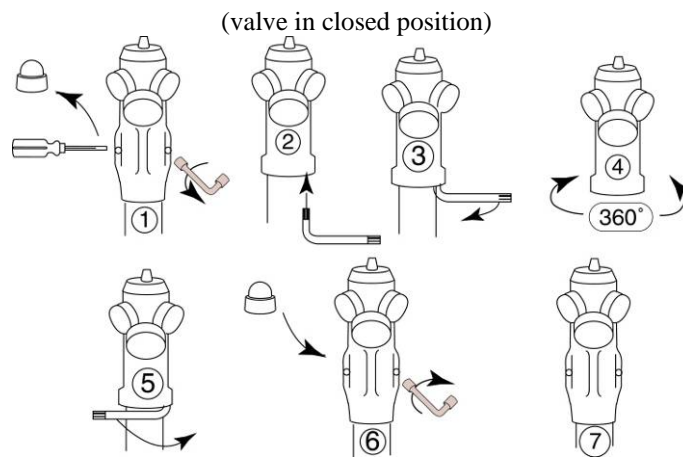

Clé à pipe de 13 et clé 6 pans de 10

Start up of the fire hydrant after purge of the network and operation in service

To make sure that the hydrant is closed

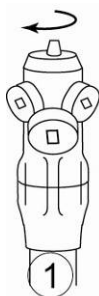

To open one outlet



To purge the pipe at high flow

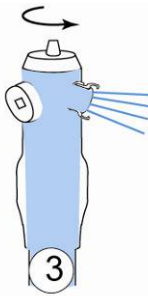

To check the draining of the hydrant



To close the outlet

