

## Tee PUR PUX with 3 Fixed Flanges

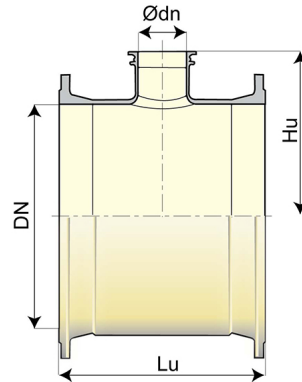

DN (mm)	Ødn (mm)	Lu (mm)	Hu (mm)	PN 10	
				Mass (kg)	References
1200	1200	1900	950	1810.00	BBC12TE1BUU
1400	1000	2470	1040	2535.00	BBC14TE1VUU
1600	1000	2065	1150	3216.00	BBC16TE1VUU
1600	1600	2730	1240	3670.00	BBC16TE1EUU
1800	1400	3050	1320	5645.00	BBC18TE1CUU
2000	1400	2635	1430	6000.00	BBC20TE1CUU

### Field of use:

- Aggressive or soft waters
- For high corrosive soils, industrial pollution zones

### Main characteristics:

- Internal-external coating : polyurethane coating in accordance with Standard EN 15655
- In conformity with EN 545:2010 and ISO 2531:2009

## Linked products

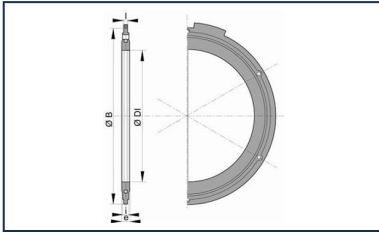

Flanged joint with hot  
galvanized steel bolts,  
nuts and washers

*The information on this sketch is, to the best of our knowledge correct at the time of printing. However Saint-Gobain are constantly looking at ways of improving their products and services therefore reserve the right to change without prior notice, any of the data shown. Any orders placed will be subject to our Standard Conditions of Sale, available on request.*