

## ULTRAQUICK

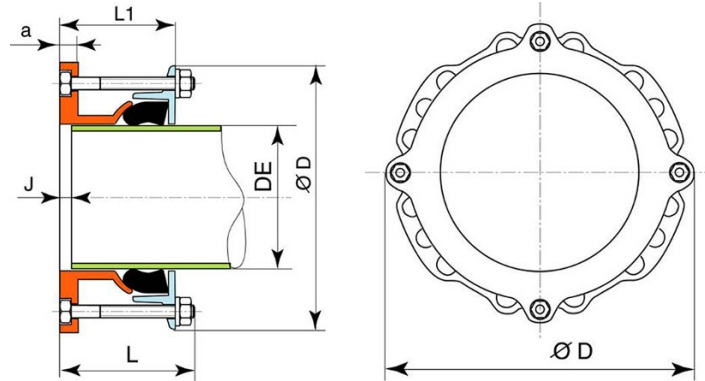

Version with carbon steel screws

Type	DN flange (mm)	ØDE mini (mm)	ØDE maxi (mm)	L (mm)	L1 Mini/Maxi (mm)	Øa (mm)	D (mm)	J Mini-Maxi (mm)	Mass (kg)	References
A	50/60	49	71	142	82-106 mm	17	178	4-32 mm	3.30 kg	MAA50HACHA
B	50/60/65/80	62	84	142	82-106 mm	17	196	4-32 mm	4.10 kg	MAA50HACHB
C	65/80	80	102	142	83-107 mm	18	209	5-31 mm	4.30 kg	MAA65HACHC
D	100	97	127	142	84-115 mm	17	242	7.30 mm	6.00 kg	MAB10HACHD
E	125 + 150	123	153	142	87-118 mm	17	280	8-29 mm	7.90 kg	MAB12HACHE
F	150	151	181	142	87-119 mm	17	297	9-27 mm	8.50 kg	MAB15HACHF
FP	200	170	200	142	88-120 mm	18	337	10-26 mm	10.70 kg	MAB20HACHP
G	200	196	226	142	95-127 mm	18	348	12-35 mm	10.70 kg	MAB20HACHG
H	200	211	241	172	105-138 mm	18	363	13-34 mm	11.00 kg	MAB20HACHH
I	250	235	265	172	97-130 mm	20	402	14-33 mm	15.20 kg	MAB25HACHY
J	250	260	290	172	113-147 mm	20	409	15-36 mm	14.40 kg	MAB25HACHJ
JR	300	285	315	173	101-135 mm	22	459	16-35 mm	20.20 kg	MAB30HACHR
K	300	306	336	173	106-141 mm	22	459	18-40 mm	19.40 kg	MAB30HACHK
L	300	318	348	173	117-152 mm	22	469	18-48 mm	18.90 kg	MAB30HACHL



## Using range depending on type of pipe

Type	ULTRA		Old grey iron						Ductile iron	Steel	PVC	Asbestos cement		
			Pipes (lead joint)		Express Pipes		Pipes Rapid							
	DE mini	DE maxi	DN	DE	DN	DE	DN	DE	DN	DE	DE	DE	DN/class	DE
A	49	71	40	56	40	57			40	56	51 - 54 - 57	50	40CI25	60
			50	66	50	67			50	66	60,3 - 63,5 - 70	63	50 CI10	66
B	62	84	50	66	50	67			50	66	63,5 - 7 - 76,1	63	50 CI10, CI25	66 - 74
			60	77	60	77	60	81.4	60	77	82,5	75	60 CI10-15, CI25	76 - 80
C	80	102	80	98	80	98			80	98	88,9 - 101,6	90	60 CI30	84
													80 CI10-15, CI25	96 - 100
D	97	127	100	118	100	118	80	102,2	100	118	101,6 - 108	110	80 CI25, CI30	100 - 104
							100	123					114,3 - 127	125
E	123	153	125	144	125	144	125	149	125	144	133 - 139,7	125	100 CI30	130
													141,3 - 152,4	140
F	151	181	150	170	150	170	150	175	150	170	159 - 168,3	160	125 CI30	161
														177,8
FP	170	200	175	196	175	196					177,8 - 193,7	200	150 CI15, CI20	174 - 178
														150 CI25, CI30
G	196	226	200	222	200	222	175	201	200	222	219,1	200	175 CI15, CI20-25, CI30	199 - 207 - 225
														225
H	211	241	200	222	200	222	200	227	200	222	219,1	225	175 CI30	225
I	235	265									244,5	250	200 CI20-25, CI30	238 - 246

Type	ULTRA		Old grey iron						Ductile iron	Steel	PVC	Asbestos cement		
			Pipes (lead joint)		Express Pipes		Pipes Rapid							
	DE mini	DE maxi	DN	DE	DN	DE	DN	DE	DN	DE	DE	DE	DN/class	DE
J	260	290	250	274	250	274	250	279	250	274	273		250 CI15	280
JR	285	315										315	250 CI20-25, CI30	292 - 306
K	306	336	300	326	300	326	300	331	300	326	323,9	315	300 CI10, CI15	324 - 334
L	318	348	300	326	300	326	300	331	300	326	323,9		300 CI10, CI15	324 - 334

## Field of use

- The range ULTRAQUICK is designed for the drinking water networks, the fire networks, and the irrigation networks.
- The EPDM elastomer type WC in conformity with NF EN681-1 can be used in sewage networks and rain water networks

## Design characteristics

- The ultra large tolerance flange adaptors cover all the outside diameters of pipe (DE) from 49 to 348 mm, without discontinuity,
- For each model the maximum DE is higher than the minimum DE of the following model : ex: DE Maxi A = 71 DE Mini B = 62 - Margin =9 - DE Maxi H = 241 DE Mini I = 235 - Margin =6
- Possible angular deflection: 6 degrees (see drawing page 4).

## Material and coatings

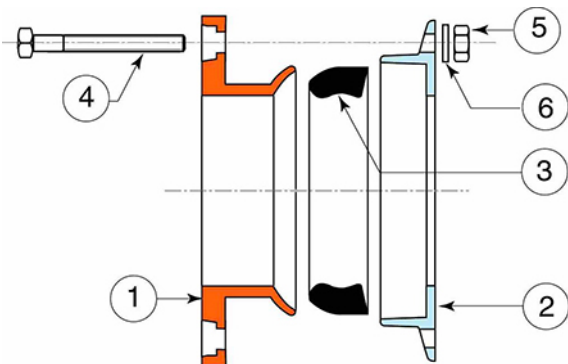

## Version with carbon steel screws

Item	Component	Material	Coating
1	Body	FGS	Blue epoxy powder 250 microns average thickness with a minimum of 200 microns, conforming to EN 14901-1 (PECB)
2	Gland ring	FGS	Blue epoxy powder 250 microns average thickness with a minimum of 200 microns, conforming to EN 14901-1 (PECB)
3	Sealing ring	EPDM (*)	
4	Bolt	Grade 6.8 steel	Geomet 720
5	Nut	Grade 6 steel	Geomet 720
6	Washer	Mild steel	Geomet 720

(\*) EPDM elastomer type WA, WC in conformity with NF EN681-1 for drinking water networks, fire networks, irrigation networks, sewage networks and rain water network.

## Marking

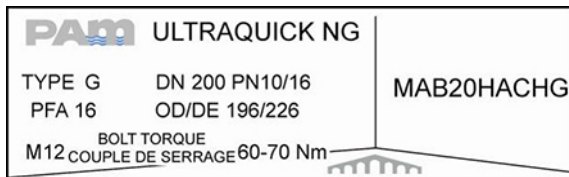

## Installation

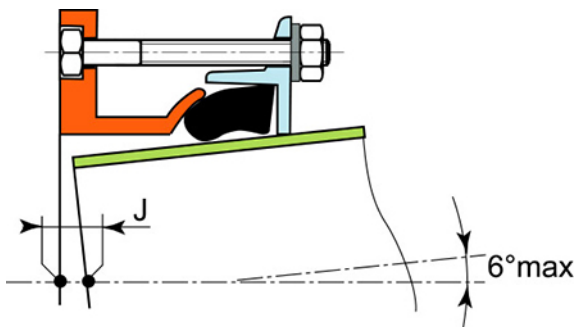

- The ultra large tolerance flange adaptors cover all the outside diameters of pipes (DE) from 49 to 348 without discontinuity. For each model the maximum DE is higher than the minimum DE of the following model : ex: DE Maxi A = 71 DE Mini B = 62 - Margin = 9 - DE Maxi H = 241 DE Mini I = 23 - Margin = 6
- Linking with all the normalized flange pieces according to : ISO 7005-2 - ISO 2535 - EN 1092-2
- Possible angular deflection : 6 degrees

- J measured on the axis
- Maximum angular deflection of 6° with J maxi for a section at 90° of the pipe
- Screwing of the bolts diametrically opposite to a torque included between 60 and 70 Nm.
- Linking with a wafer valve to be avoided

## Centering Tab Gasket



Type	Mass	References PN10	References PN16
	kg		
A-B	0.020	MJA60UAXA	MJA60UAXA
C	0.030	MJA80UAXA	MJA80UAXA
D	0.040	MJB10UAXA	MJB10UAXA
E	0.060	MJB12UAXA	MJB12UAXA
F	0.090	MJB15UAXA	MJB15UAXA
FP-G-H	0.120	MJB20UAXA	MJB20UAXA
I-J	0.120	MJB25UAXA	162274
JR-K-L	0.090	MJB30UAXA	162275

*The information on this sketch is, to the best of our knowledge correct at the time of printing. However Saint-Gobain are constantly looking at ways of improving their products and services therefore reserve the right to change without prior notice, any of the data shown. Any orders placed will be subject to our Standard Conditions of Sale, available on request.*