

Washout Flanged Tee (PUR-PUX) (2 fixed flanges - 1 mobile flange)

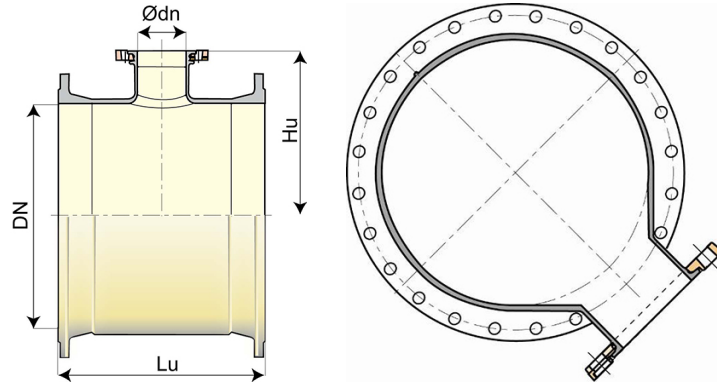

DN (mm)	Ødn (mm)	Lu (mm)	Hu (mm)	PN 10	References
1500	400	1530	960	1725.00	BBC15UV1NUU
1600	400	1610	1100	2166.00	BBC16UV1NUU

Field of use:

- Aggressive or soft waters
- For high corrosive soils, industrial pollution zones

Main characteristics:

- Internal-external coating : polyurethane coating in accordance with Standard EN 15655
- In conformity with EN 545:2010 and ISO 2531:2009

Linked products

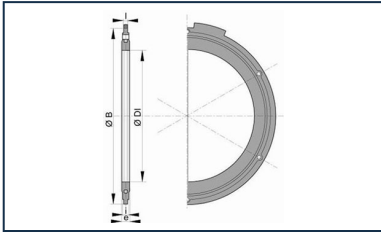

Flanged joint with hot
galvanized steel bolts,
nuts and washers

The information on this sketch is, to the best of our knowledge correct at the time of printing. However Saint-Gobain are constantly looking at ways of improving their products and services therefore reserve the right to change without prior notice, any of the data shown. Any orders placed will be subject to our Standard Conditions of Sale, available on request.