

## INSTRUCTIONS FOR SAFE HANDLING

**Product name: DJ – MDK DISMANTLING JOINT**

**Maximum working (operating) pressure**

- PN 10 = 10 bar
- PN 16 = 16 bar

**Maximum operating medium temperature: 50 °C**

The DJ - MDK is manufactured from ductile iron **EN-GJS-400-15** in accordance with **EN 14525**.

**Technical Data:**

Pressure rating	Dimension	NUTS N1, N2, N3, N4	NUTS N5	Installation length – L (mm)
		Max. Bolt torque connection flange (Nm)	Max. bolt torque middle flange (Nm)	
PN 10&16	DN 080	120	40	200 ± 25
	DN 100	120	40	200 ± 25
	DN 150	180	50	200 ± 25
PN 10	DN 200	180	50	220 ± 25
	DN 250	180	50	220 ± 25
	DN 300	180	50	220 ± 25
	DN 350	180	50	230 ± 25
	DN 400	300	60	230 ± 25
	DN 500	300	60	260 ± 25
	DN 600	350	70	260 ± 25
PN 16	DN 200	180	50	220 ± 25
	DN 250	300	60	230 ± 25
	DN 300	300	60	250 ± 25
	DN 350	300	60	260 ± 25
	DN 400	350	70	270 ± 25
	DN 500	420	80	280 ± 25
	DN 600	500	90	300 ± 25

Table 1

### INTRODUCTION

The IMP DJ-MDK enables installation of valves into a fixed pipeline. Its adjustable length allows precise flange alignment and compensation for minor deviations between pipes or equipment. The DJ-MDK is designed to ensure tight sealing even under vibration or temperature changes.

The DJ-MDK can be used in drinking water networks, wastewater systems, or networks with neutral liquids. Correct selection of the interflange gasket is essential.

Operating conditions are limited by temperature and pressure as specified: typically between 0 and 50 °C and up to 16 bar differential pressure.

The DJ-MDK housing is made of ductile iron, while bolts, nuts, and washers are made of stainless steel.

## HEALTH AND SAFETY MEASURES

During installation and operation of the IMP MDK, hazards associated with pressurized liquids and gases must be considered. Never attempt to dismantle or disassemble the DJ-MDK while it is installed in a pressurized pipeline.

MDK units, especially larger sizes, are heavy; therefore, always use suitable lifting equipment to prevent injuries.

Personnel performing any work related to the DJ-MDK must be properly trained to avoid potential injuries or accidents. These safety handling instructions do not replace the required professional training and skills. The company IMP neither Saint-Gobain PAM assumes no responsibility for injuries resulting from improper installation or handling of the DJ-MDK.

All applicable standards, instructions, regulations, and accident-prevention rules must be observed during and after installation.

## STORAGE

Store the IMP DJ-MDK in a location protected from pollution and contamination. The DJ-MDK must be stored in an upright position. Protect the DJ-MDK from direct sunlight. Application of the FIFO (First In, First Out) principle is recommended.

## INSTALLATION

During transport, loading, and handling, the DJ-MDK must be protected against damage. When lifting with cranes or other lifting devices, always use the flange holes, installed eye bolts, or suitable lifting straps.

Pay special attention to the EPDM gasket, flanges, and surface protection. Check for any irregularities, twisted or incorrectly installed parts, scratches, or other damage. If defects are detected, they must be eliminated or the DJ-MDK replaced.

The DJ-MDK must be installed into the pipeline using appropriate gaskets, bolts, washers, and nuts. The mating flanges must comply with the standard flange drilling of the DJ-MDK. Correct installation of the DJ-MDK is a prerequisite for reliable operation.

## CORRECT INSTALLATION POSITION

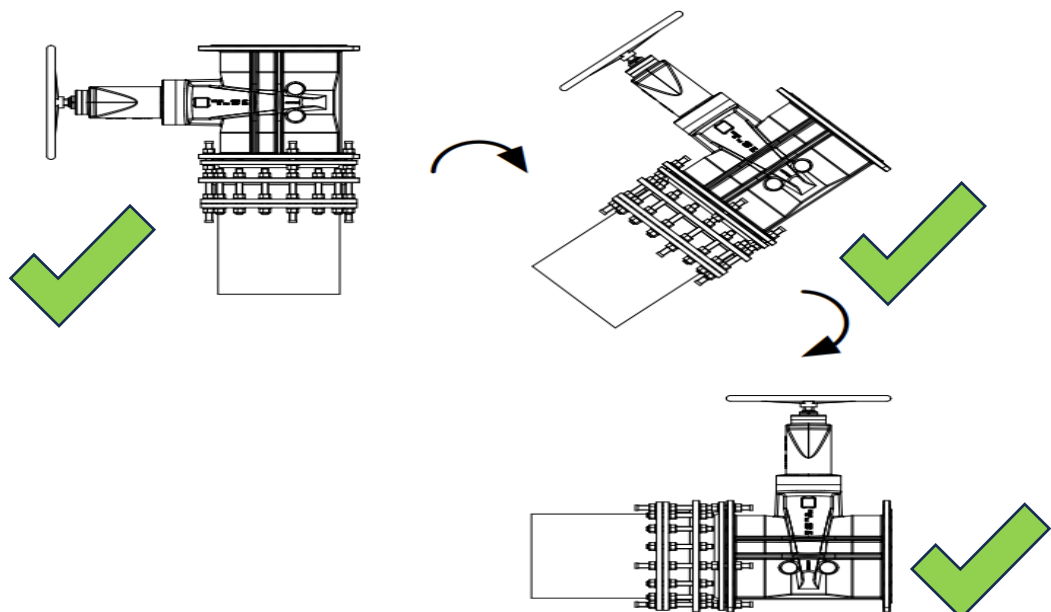

Figure 1

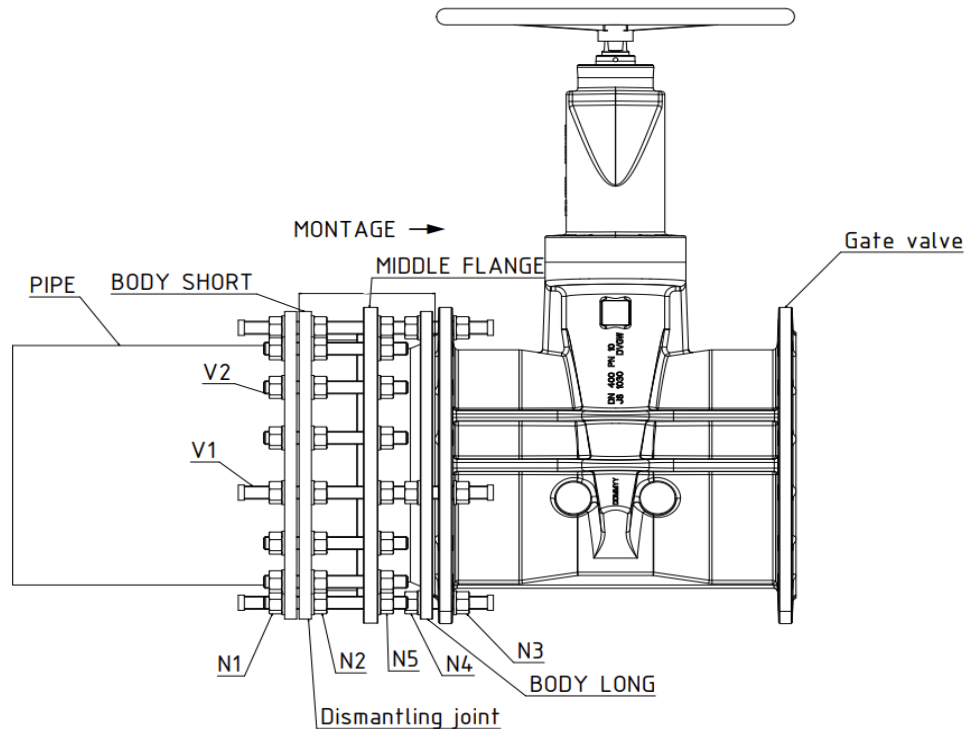

Figure 2

### Step 1 – Preparation

Before installation, the flow must be shut off or the pipeline emptied and, in the case of elevated temperature, cooled down to room temperature.

### Step 2 – Inspection

Check that all DJ-MDK parts are undamaged and complete, and that the flanges match and are properly aligned to avoid housing stress during installation.

### Step 3 – Installation into the pipeline

Insert the DJ-MDK between the pipe and the valve. The DJ-MDK must be oriented with the short body section facing the pipe. Installation starts from left to right. Insert the gasket, threaded rods, and nuts **N1** and **N2**, and tighten bolts **V1** and **V2** to 50% of the specified torque.

### Step 4 – Length adjustment

By loosening nuts **N3**, **N4**, and **N5**, adjust the axial length of the DJ-MDK (telescopic section) until the flanges are aligned.

Attach the other end of the MDK to the valve flange, insert the gasket, and tighten nuts **N3** and then **N4** to 50% of the specified torque.

Then tighten nuts **N5** again to 50% of the specified tightening torque.

First tighten bolts **V1**. Finally, insert the interflange bolts with nuts and washers. See Table 2.

### Step 5 – Final tightening

First tighten the nuts and bolts on both flanges **N1**, **N2**, **N3**, and **N4**.

Then gradually tighten crosswise in a diagonal sequence up to the specified tightening torque. For proper installation of flange gaskets, bolts must always be tightened in a criss-cross pattern (see Figure 3).

Bolt sizes for valves are specified in Table 2. Finally, tighten nuts **N5** to the specified tightening torque Table 1.

Screw dimensions – which not delivered with DJ						
DN	Pressure rating (bar)		Quantity		Screw length	
	PN 10	PN 16	PN 10	PN 16	PN10	PN 16
80	M16		6		M16X65	
100	M16		6			
125	M16		6			
150	M20		6		M20X70	M20X70
200	M20		6	8	M20X70	M20X70
250	M20	M24	8	8	M20X70	M24X75
300	M20	M24	8	8	M20X75	M24X85
350	M20	M24	12	12	M20X85	M24X90
400	M24	M27	12	12	M24X90	M27X95
500	M24	M30	16	16	M24X100	M30X105
600	M27	M33	16	16	M27X110	M33X115

Table 2

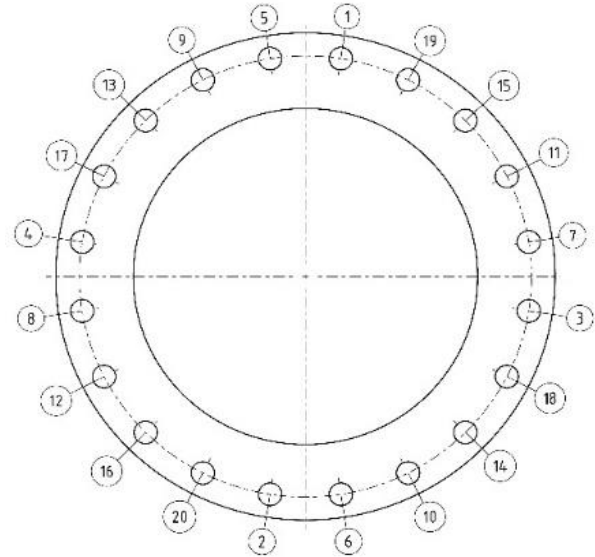

Figure 3