

Product guide : sewerage



*Innovative, sustainable
Networks adapted
to your environment*



PIPELINE SOLUTIONS FOR THE FUTURE

PAM
SAINT-GOBAIN

PAM

SAINT-GOBAIN

Dedicated to water and sewerage pipeline solutions, the PAM brand of the Saint-Gobain group Pipe Activity is the number one producer of pipe systems in the entire world.



The Technical sales department takes the customers on an upwards journey using PAMCAD, a software program to assist with the design of drinking water and sewerage networks.

Saint-Gobain PAM designs, produces and sells a complete range of solutions dedicated to the supply of potable water, sewerage and evacuation of waste water.

For over 150 years, its reputation in the pipe business has been based on its know-how, the reliability of its products, and on the level of service offered to its customers.

Through a dense sales network, Saint-Gobain PAM currently operates in more than 126 countries.

■ A high added value product

The term "cast iron" includes a wide range of iron, carbon and silicium alloys. Discovered in 1946, ductile cast iron is produced by adding a small quantity of magnesium to grey cast iron, a process which gives it exceptional properties in terms of mechanical strength and flexibility.



Saint-Gobain PAM, committed to sustainable development

Saint-Gobain PAM has always been committed a policy of sustainable development, from product design through to delivery. The company proactively ensures that the environment is protected and preserved.

■ **Ductile cast iron is a respected material, 100 % and indefinitely recyclable.**

Thanks to pipes whose weight has been reduced by one third and whose lifetime has been multiplied by three in ten years, as well as through the development of more ergonomic installation techniques, Saint-Gobain PAM is reducing its energy and raw material requirements, while significantly decreasing CO₂ emissions.

During the production cycle, all polluting emissions are filtered and all waste recycled.

The environment impact is controlled by two laboratories, one internal, the other independent. To ship the products, diversified and low energy-consuming transport methods such as rail and ship are used whenever possible.

At each step, from design to delivery, Saint-Gobain PAM strives to promote a development initiative based on responsible and sustainable consumption and production modes. Apart from management of industrial risks and their impacts on the environment, Saint-Gobain PAM has formalised its commitments in an internal "Environment, Health and Safety" charter.

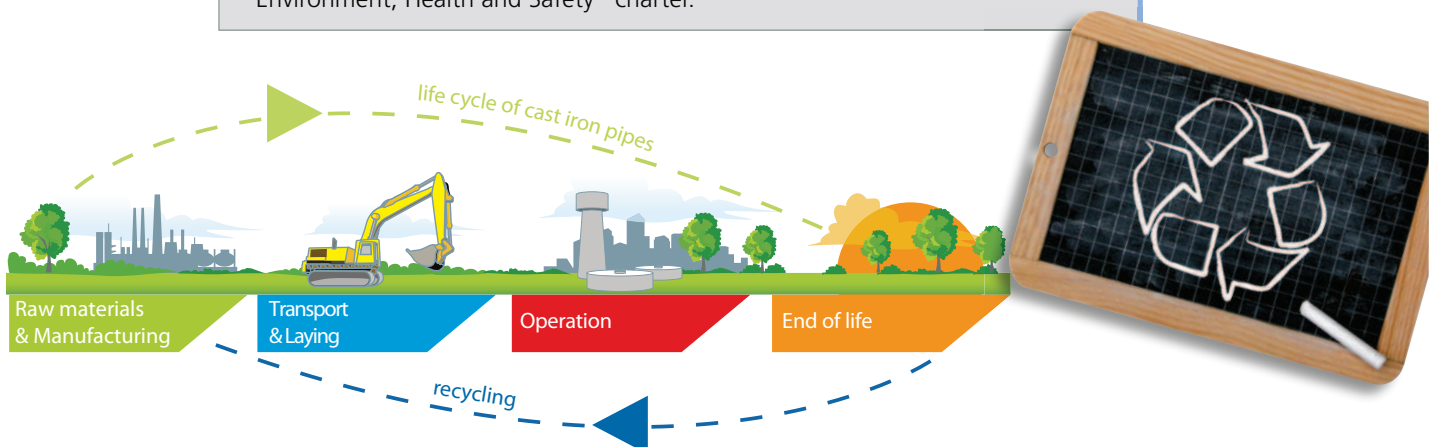



C

ONTENTS

Eco-Installation Saint-Gobain PAM	P.6
Applications.....	P.8
Technical solutions	P.16
Quality and compliance with standards	P.30



INTEGRAL® RANGE p.32

- Pipes	p.34
- Pipes for special purposes	p.36
- Gravity connections - branch connections	p.38
- Gravity connections - connections	p.40
- Gravity connections - manhole collars	p.42
- Gravity connections - access devices	p.43
- Sewer pressure mains - fittings	p.46
- Valves - shut-off valves	p.52
- Valves - protection - joints	p.53



PLUVIAL® RANGE p.54

- Pipes.....	p.56
- Junctions	p.57



TAG 32® RANGE p.58

- Pipes.....	p.60
- Branch connections	p.62
- Fittings and branch connections	p.64
- Bends	p.65
- Sleeves	p.66
- Connecting parts	p.68
- Connection to other materials	p.70
- Plugging	p.72
- Connection to concrete manhole covers	p.73

REPAIR PRODUCTS FOR PIPES AND FITTINGS p.74



ECO-INSTALLATION : natural pipeline installation

Compared with a traditional site, PAM Eco-Installation eliminates two stages: the transport of soil and the delivery of new materials.

■ **PAM Eco-Installation, is economical**

Using "native" soil for backfill and reduced widths mean that there is less need for sand quarries and fewer needless lorry journeys!

■ **PAM Eco-Installation, is environmentally friendly !**

In addition to CO₂ savings, PAM Eco-Installation means less disruption for local residents and saves natural land resources.

ECO-INSTALLATION SAVINGS

- **COATING** = less filler material.
- **FEWER LORRY JOURNEYS** = lower CO₂ emissions.
- **MATERIAL = DUCTILE CAST IRON** = continuously recyclable.

DID YOU KNOW?

"The French Public Procurement code requires public buyers to take sustainable development concerns into account when defining their requirements" (art. 5)

The sustainable development requirement is set out in the following articles:

- Art. 6: definition of public buyer requirements.
- Art. 14: contract execution conditions.
- Art. 45: the candidate's environmental protection capabilities.
- Art. 53: bid selection criteria.

Source: www.ecoresponsabilite.environnement.gouv.fr/article.php3?id_article=584

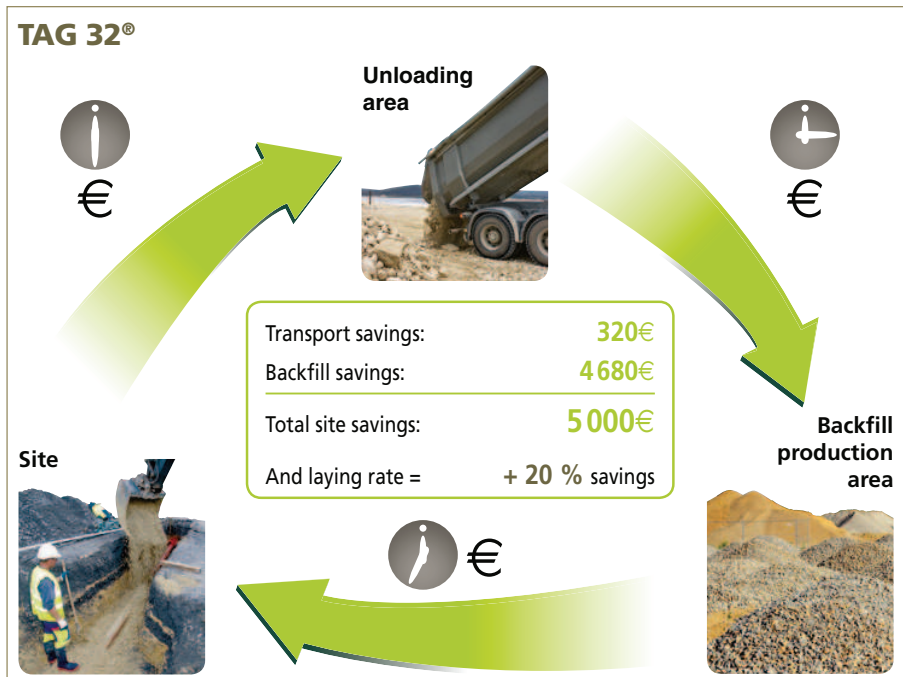



Highly resistant, tough and flexible, PAM ductile cast iron pipelines allow you to reuse natural soil to backfill trenches. Simplified, economical and environmentally friendly laying!

Traditional laying

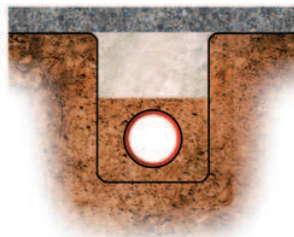

1,70 m
Volume = 4.42 m³

Eco-Installation Tag 32[®] pipes



1,10 m
Volume = 2.86 m³
- 54%

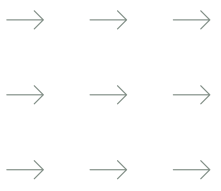

All the guarantees of a system which is **tough, watertight and sustainable!**

→ ENVIRONMENTAL PROTECTION

- *Leaks and effluent losses*
- *Preservation of the water table*

The PAM solution

■ A perfectly leaktight pipe system

All castings, pipes and fittings are made of ductile cast iron and provide exceptional mechanical properties.

Strong and impermeable, they adapt to changes in their environment without breaking or cracking and they exclude all possibility of infiltration. Moreover, they are not open to parasite connections.

STANDARD joints are used for junctions: they are activated by compression and have well and truly proven their suitability in water distribution applications.

The elastomers used for joint gaskets are carefully selected for their ability to maintain their mechanical and physico-chemical properties over time.

The PAM sewerage system is leaktight: it does not lose any wastewater and it does not allow any clear water infiltration.

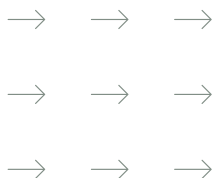
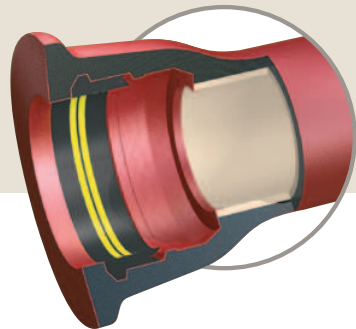



➔ SAFETY AND ENVIRONMENTAL NEEDS

- ➔ *Changes in the mechanical context*
- ➔ *Operational hazards*
- ➔ *Soil loads*

The PAM solution

■ Material durability

Ductile cast iron pipes benefit from the extraordinarily longevity of cast iron.

Combining flexibility with strength, ductile cast iron has remarkable properties: bending strength and resistance to elongation.

Unbreakable, ductile cast iron overcomes the potential problems from clean breaks or insidious cracks.

PAM cast iron pipelines can withstand considerable mechanical stresses, site and operation hazards, without damage.

They can withstand earth loads, landslides, ground movements, traffic loads, etc.

Outside, zinc galvanic protection and paint protection guarantee pipeline integrity in most types of soil encountered.

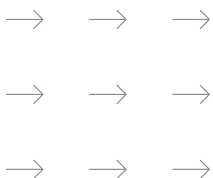

→ REQUIREMENTS OF GRAVITY SYSTEMS

- *Hydraulic capacity and respecting the water flow*
- *Abrasion resistance*
- *Chemical resistance*

The PAM solution

■ Long service functions

Rigid and straight, PAM 3, 6, 7 and 8 metre long sewerage pipes, guarantee continuity in the water stream.

The hydraulic capacity of cast iron pipes is demonstrated by the fact that their internal diameter is at least equivalent to the nominal diameter (DI=DN).

The internal diameter of TAG 32® pipes is even greater than the nominal diameter.

Junctions are few and self-centred, and so do not create any obstacles to the flow.

The pipes are lined with a very compact and perfectly smooth cement mortar or an epoxy that promotes smoother flow, resists abrasion and provides good chemical resistance.



→ → →

→ → →

→ → →

→ OPERATING CHANGES

- *Population growth*
- *Accidental overload*

The PAM solution

■ Durable solution

The capacity of a system to fulfil its role over time involves considering the future or foreseeing exceptional operational conditions.

PAM cast iron pipelines have a safety margin to cope with accidental network overload, with no loss of tightness.

PAM pipelines are able to operate at a high rate, until their limit is reached, without the need to resize the network. They withstand high-pressure water cleaning so that foreign bodies can be cleaned out.

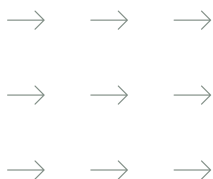
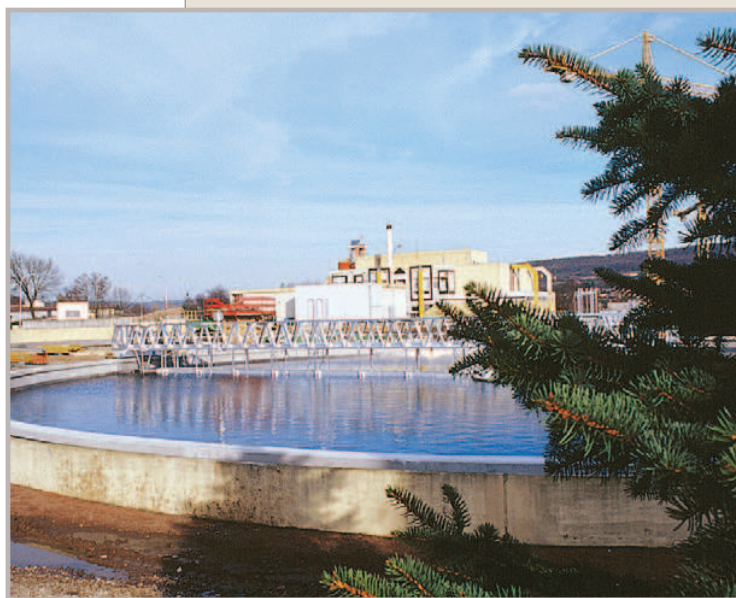

→ ADAPTABILITY - SAFETY

- *Suited to all zones*
- *Possibility of modifying routes to bypass obstacles*

The PAM solution

■ A complete and homogeneous range

INTEGRAL® : DN 80 - 2000

PLUVIAL® : DN 350 - 2000

TAG 32® : DN 150 - 300

A complete range of ductile iron castings for rising main and/or gravitational sewers to suit all site configurations.

Thanks to their characteristics they are versatile, they can cross even difficult areas and simplify routes - steep slopes, rocky areas, along the water table, in rivers.

The ingenuity of some castings means that obstacles can be bypassed without redesigning the layouts.

ViLoK®, a new range of STANDARD VI® NBR quality self-anchored junctions means that INTEGRAL® pipelines can be self-restrained (under pressure), improving operational safety and avoiding the need for concrete thrust blocks.

A set of standardised and certified products

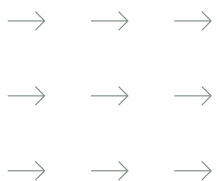

→ OVERALL PROFITABILITY

- *Easy to install*
- *Cleverly designed products to help facilitate pipe laying*
- *Immediate and lasting leaktightness*
- *Low maintenance*

The PAM solution

■ Solid and simple pipes

Thanks to their mechanical strength, PAM pipes are simple to lay under deep or shallow cover, and compaction and backfill are limited to the absolute minimum.

Laid in compliance with standard practices, PAM pipes guarantee immediate leaktightness, confidence during testing and at no additional cost.

The long lengths and the limited number of joints reduce opportunities for build-up of debris, thus also reducing the need for network maintenance or service.

The supply cost must be considered within the total project cost. Considering overall cost means also including indirect costs, as well as medium and long term factors.

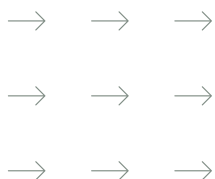

→ PRESSURE RESISTANCE

- *Operational risks: overpressure, water hammer*
- *Network homogeneity*

The PAM solution

■ Pipes for pressure sections

Thanks to Saint-Gobain PAM know-how, gained from an understanding of drinking water supply networks, the high safety factor of ductile cast iron and the performance of the elastomer joints, INTEGRAL® pipelines are manufactured to operate under gravity as well as under pressure, even accidental pressure.

Compatible and uniform parts guarantee optimal operation over the entire pipeline.

Air valves and specific valves complete this offer.

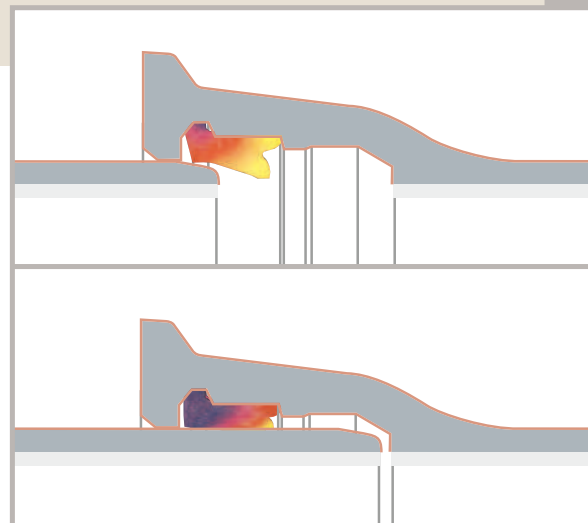

Perfect watertightness by using elastomer joints.

→ → →

→ → →

→ → →

➔ CONNECTIONS AND PROPERTY BOUNDARIES

- ➔ *Ready-to-use solutions*
- ➔ *Search for simplified adjustments*

The PAM solution

■ **Ergonomic parts**

Swivel saddle branch on sewer:

- 360° rotation
- 45° inclination

Ideal solution to bypass obstacles.

Simple or single-block round connection chamber DN 250 and 300 with downstream, fixed or rotatable pipe.

Simple connections and bends.

Connecting parts for connections with other materials.

A set of parts designed with installers for greater flexibility when implementing branch connections.

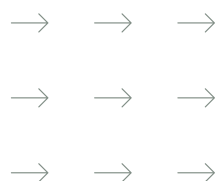
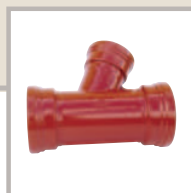

All the guarantees of a deformity resistant, linear system!

➔ MECHANICAL STRENGTH OF THE INTEGRAL® / PLUVIAL® RAN

The behaviour of ductile cast iron pipes is a compromise between that of flexible and rigid materials. Consequently, their mechanical properties combine the advantages of both types.

Cast iron is a ductile, and therefore elastic material, which offers an elongation at rupture > 10 %.

Although the system is never stressed to this value, it represents a significant safety margin.

The buried pipeline may be subjected, over time and in unstable ground for example, to differential soil compaction or to settlements due to water circulation which destabilises the trench bottom.

Due to the strength and elasticity of ductile cast iron, the pipeline systems can absorb the inevitable stresses or changes occurring in the immediate surroundings without breakage or joint separation.

Buried pipes are also stressed mechanically by the loads due to the backfill (earth or permanent loads), in addition to intermittent loads

PRODUCTS SUBJECTED TO



Crushing strength of a GRP tube

(circulation loads or traffic loads).

It is therefore important to select a pipeline with an adequate safety coefficient, to avoid problems caused by breaks, cracks, flexion or ovalisation leading to spillage into a water channel.

The ideal complement for these pipelines are the elastomer gaskets which give the system a degree of flexibility, representing a safety factor when crossing heterogeneous or unstable ground.

When subsidence is extended and uniform, the gasket allows the pipeline to behave as a flexible chain in order to take up the mechanical forces.

This feature also eliminates the need to install connecting rods near manholes.

→ → →

→ → →

→ → →



GES

STANDARDISED CRUSHING TESTS

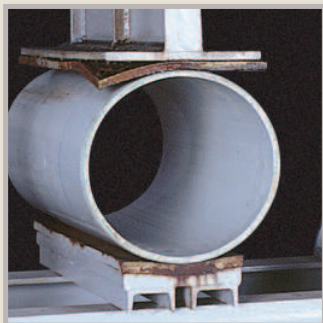

Crushing strength of a PVC tube

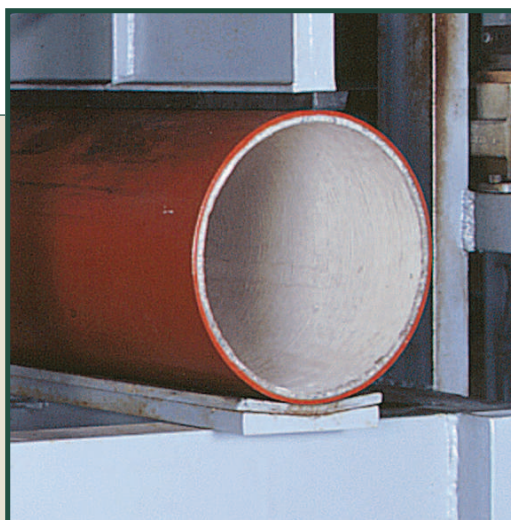

Crushing strength of a ductile cast iron pipe

Due to the rigidity of ductile cast iron, the PAM pipeline system resists deformities and retains its linearity, ensuring respect of the water flow.

What seems like a mechanical paradox should be considered with interest, since it is the combination of these characteristics which gives the PAM pipeline system its longevity, ensuring it remains watertight over time, in spite of contingencies.

DN	Rigidity kN/m ²	Ovalisation %
150	230	1,9
200	105	2,5
250	66	2,8
300	47	3,0
400	31	3,2
500	22	3,4
800	20	4,0
1000	16	4,0



DIAMETRICAL RIGIDITY OF THE TAG 32® RANGE

Corresponds to 32 kN/m² and meets the need for performance in the gravity market perfectly.

DN	Rigidity kN/m ²	Ovalisation %
150	74	2.7
200	32	3.75
250	32	3.6
300	32	3.7

→ → →

→ → →

→ → →

➔ **WATERTIGHTNESS/IMPERMEABILITY
IN PRESSURISED SECTIONS**

With the standard NBR joint, the PAM pipeline system is a combination of homogeneous parts designed to produce structures which are, and remain, watertight.

The PAM solution

The PAM ductile cast iron system displays excellent mechanical properties; **the junction is the key element to guarantee watertightness of the structures, whether they operate by gravity or under pressure.**

PAM pipeline junctions

(STANDARD or TAG 32® types) are made by simply pushing the pipes together, the gaskets being under high radial compression: the compression rates can reach 30 to 40 %.

The elastomers chosen withstand the most severe tests, corresponding to their application. They are selected to retain their mechanical and physico-chemical characteristics over a long period of time. The tightness performance of the PAM system joints, under extreme conditions of use, is designed to cope with the mechanical stresses that the junctions are likely to suffer with time, such as shear, deflection or accidental loading.



The compression rate of the elastomer gaskets prevents seepage, surface leakage, penetration of roots or pebbles at the junctions which can lead to the loss of water tightness of the networks.

The specific design of PAM joints makes decompression impossible under shear forces.

These features protect the environment and preserve the water tables.

→ → →

→ → →

→ → →

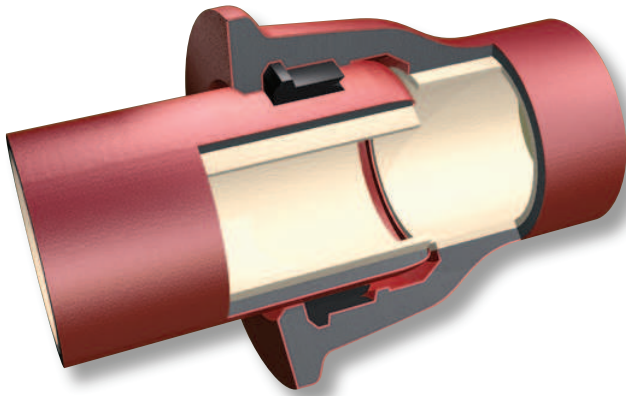

INTEGRAL® junction with standard joint

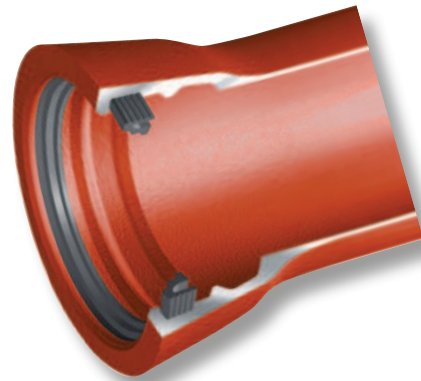

TAG 32® junction with TAG joint

NITRILE* HR quality was chosen for all joints in the PAM system to withstand the effluents encountered in sewage.

This grade complies with the requirements of the European standard: EN 681-1 type WG.

* NITRILE = N.B.R. (identified by yellow marking).

PERFORMANCE OF INTEGRAL® PLUVIAL® /TAG 32® SYSTEMS				
	Internal pressure	External pressure	Shear force	Factory test
GRAVITY - water	2 bar	1 bar	30 times DN (in Newtons)	-
- air	200 millibar	-		
PRESSURISED	> 20 bar	1 bar		> 25 bar

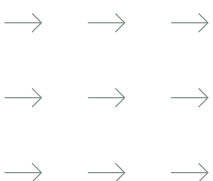

PAM is the guarantee that the pipeline will be watertight first time, with no surprises when the tests are carried out, and will remain watertight!

➔ **MECHANICAL SAFETY: SAVINGS DUE TO THE TYPE OF MATERIAL**

The characteristics of ductile cast iron give the PAM system significant advantages during implementation: this highly robust material simplifies the backfilling and compacting operations in particular.

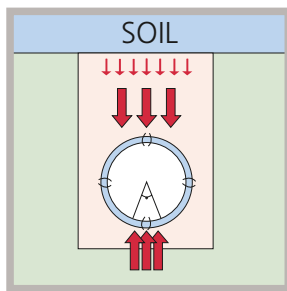

Rigid pipelines concentrate the earth loads and the bedding angle must be respected to avoid the risk of brittle fracture (e.g. bed washed away).

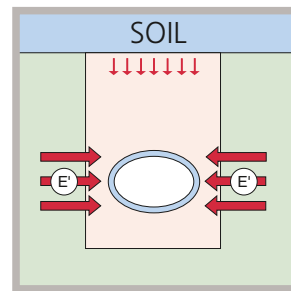

Flexible, deformity resistant pipelines require good base support and therefore careful compacting, in order to limit ovalisation (which reduces their useful cross-section and produces a risk of leakage at the joints)

■ **SAFETY WHEN LAYING**

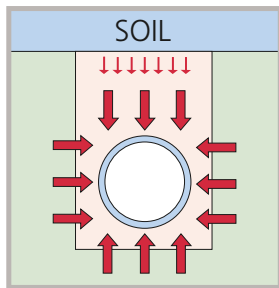

PAM ductile cast iron pipelines are semi-rigid.

The elasticity of the material makes laying easier and therefore cheaper. They can cope with certain inevitable laying difficulties due to unstable ground, without damage, better than the other pipes.

The performance of the PAM system combined with relative independence from laying conditions, offers the following advantages:

- savings during implementation, in the usual cases (simplified compacting, reuse of site earth),
- safety margin on sites with high constraints (laying on water table, unstable ground, deep or shallow laying, etc.)

When designing its sewerage pipelines, Saint-Gobain PAM took into account the need for a product offering a high safety margin in order to compensate as much as possible for design calculation uncertainties and unstable ground.



➔ MECHANICAL STRENGTH

■ FASCICULE 70

Fascicule 70 "Sewerage structure general technical specifications" (November 2003 edition) requires proof of the mechanical strength of pipes in their environment.

The design method applicable to all materials involves making changes to a certain number of parameters, in order to determine the allowable depths of cover.

Note: To help you, Saint-Gobain PAM has developed software for the mechanical design calculation of pipelines according to Fascicule 70 based on current standards. Please consult us.

You can also download the software from our site www.pamline.fr after consulting your regional management.

NB : each site will of course be designed according to the method defined in Fascicule 70.

Summary of parameters to be used:

- modulus of elasticity: 170 000 MPa(E_T)
- ratio $E_{T_v}/E_{T_i} = 1$
- Poisson's ratio: $\nu_T = 0.25$
- e_o (mm) = $1.2 + DN/2000$



■ DEPTHS OF COVER (H_c)

The following charts show the most frequent examples. They are the result of calculations made using the Fascicule 70 method.

INTEGRAL® PIPE ECO-INSTALLATION
Maximum depths of cover

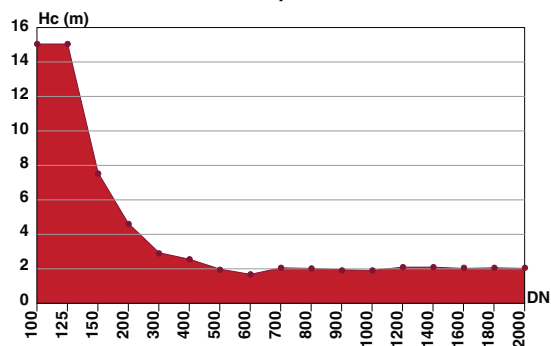

INTEGRAL® PIPE USUAL INSTALLATION
Installation maximum depths of cover

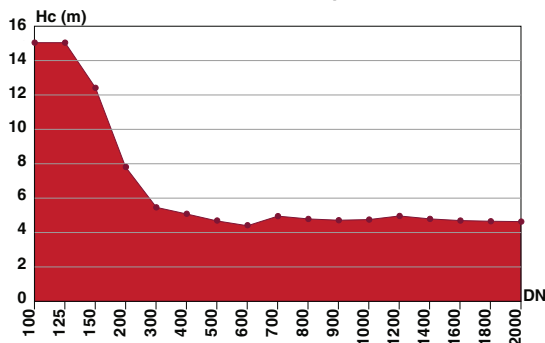

INTEGRAL® PIPE HIGH QUALITY INSTALLATION
Maximum depths of cover

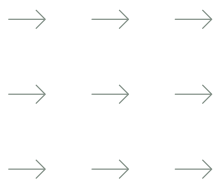
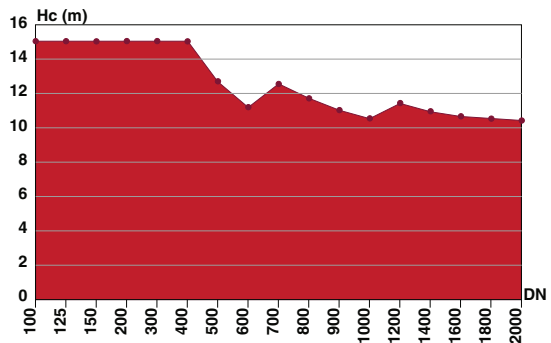

➔ **RESPECT OF THE WATER FLOW**

A sewerage pipeline must be able to absorb the environment changes without deformation, crushing or ovalisation which could result in interruption of the water flow.

Due to the mechanical properties of ductile cast iron, there is no risk of breakage or misalignment during possible soil movements or nearby excavations.

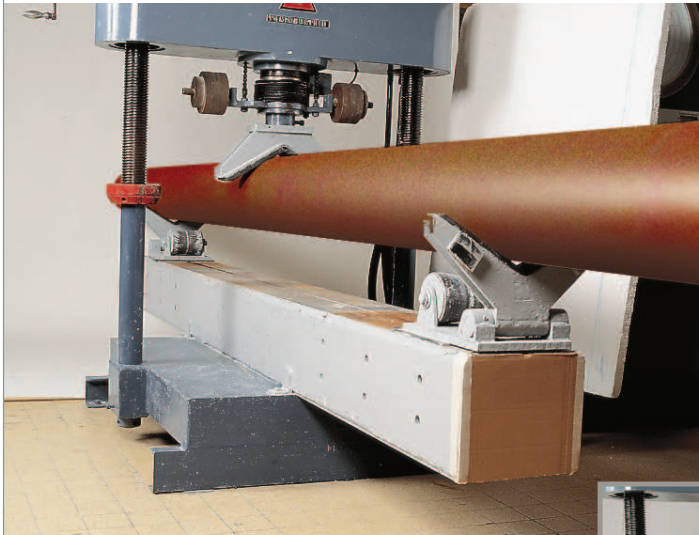

INTEGRAL®

Offering the safety factors inherent to ductile cast iron, PAM rigid and straight pipes guarantee the quality of the water flow:

- the long pipe lengths and their smooth internal wall contribute to self-cleaning,
- the fittings of cross-section identical to that of the pipe and the elastomer joint gasket guarantee centring and prevent the possibility of blockages.

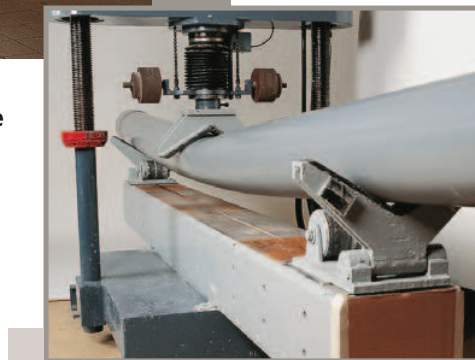

Flexible materials

Standard NF EN 476 specifies the allowable values concerning the continuity of the water stream at the junctions.

< 6 mm for DN's up to 300 0.02 x DN for DN's > 300 (max. 30 mm). The allowable difference on the PAM system junctions is always below the requirements specified in the standard. See watertightness / impermeability p.18.

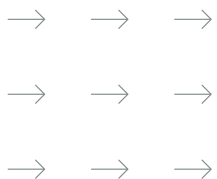

→ **HYDRAULIC CAPACITY**

Since the sewerage pipelines operate intermittently, with daily peaks, and in view of possible changes of the demographic situation, network design must cater for unexpected events.

In addition to the safety factor of ductile cast iron, the PAM system offers hydraulic advantages, which represent a guarantee of trouble-free future:

- A perfectly smooth internal wall: **epoxy or high alumina cement mortar applied by spinning improves water flow.**

- Inner diameter at least equivalent to the nominal diameter:

- extra capacity available for higher flows (e.g. peaks and urban growth),

- dimensions of the systeme can therefore be optimised.

- The pipes are straight and resistant to deformities: under stress, the permitted ovalisation is limited to 4 % (extreme conditions).

The flow coefficient K in the Manning-Strickler formula is 105 for cement lined ductile iron pipes, depending on the design of the gravity network (number of manholes and connections, slope...).

K can be chosen between 80 and 90 in accordance with EN752.

The Colebrook-white formula is universally used for determining the head losses in pipelines flowing full, with a coefficient $k = 0.1$ mm for cement lined ductile pipes.

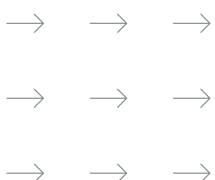
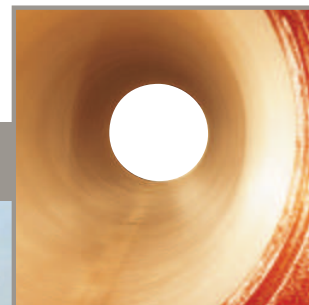

The water stream and the flow capacity are always maintained.

➔ RESISTANCE TO ABRASION

The networks carry effluents loaded with foreign bodies, which is especially true for networks collecting runoff water. In gravity sewerage, the land topography sometimes requires high flow rates. In this case, the foreign bodies may cause abrasion.

There are several types of abrasion:

- wear by scratches, which is limited if the pipeline wall is harder than the particle,
- wear by shocks, reduced if the surface material is elastic.

The ideal solution would be to have a material which is both very hard and very flexible. High alumina cement mortar offers excellent resistance to the usual flow conditions and can withstand excess speeds, even of short duration, without damage and without jeopardizing the longevity of the pipelines (reduction in thickness or mechanical resistance).

- Sales engineers and investigation resources are available to carry out detailed studies of special cases, especially mountain areas.

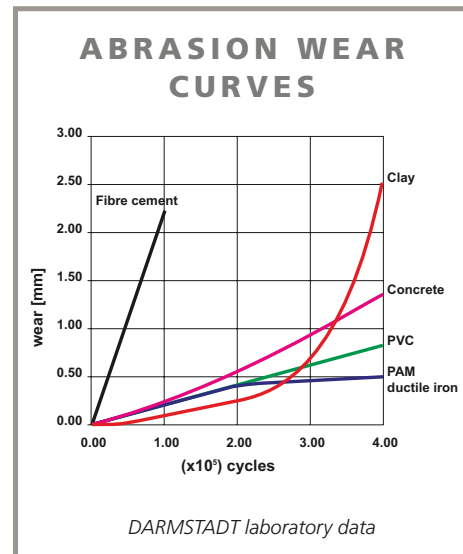

- Significant project costs savings can be made by eliminating flow control chambers and manhole backdrops.

➔ RESISTANCE TO JETTING

Complete systems for sewer applications which meet the Jetting requirements of DIN 19523.



■ High pressure cleaning test

Our ranges are tested. These tests are carried out according to the new German standard DIN 19523 with pipes from all our sewer ranges and their branch connections (P = 200 bar).

■ Results

- Perfect seal.
- No damage to the lining.
- No detachment of the lining.

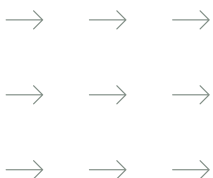

→ SOIL CORROSIVENESS

Pipelines are subjected to the constraints of the environments in which they are buried, including soil and backfill corrosivity.

The general corrosivity levels are determined using topographical and geological readings.

They can be completed in the field, by resistivity measurements and sample analyses.

■ PAM pipes are coated with metallic zinc sprayed at a rate of 200 g/m² or a zinc-aluminium ZINALIUM[®] alloy at a rate of 400 g/m². or BioZinalium

This lining is completed with a brown/red epoxy or acrylic pore sealer.

The zinc acts as:

- a galvanic protective coating by forming stable, insoluble zinc salts,
- damage self-healing: the Zn⁺⁺ ions migrate through the pore sealer to heal the damage.

Zinc 99% 200g/m²

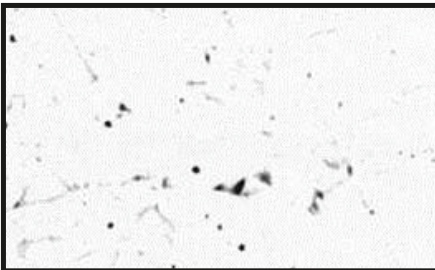

100% active protection. Homogeneous dissolution of the sacrificial coating

Zinalium[®] Zn85 Al15 400g/m²

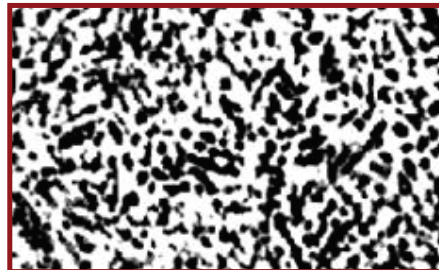

Decrease in the rate of dissolution of Zinc due to the formation of the Zinc-Aluminium alloy matrix. Increase in the lifetime of the sacrificial coating vs Zinc 200g/m²

BioZinalium[®] Zn85 Al15 (Cu) 400g/m²

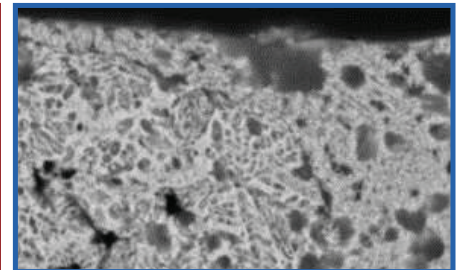

Improvement of the reactivity of Zinc salts in case of damage allowing a faster implementation of the protection against injuries or risks of biocorrosion

Self-healing process

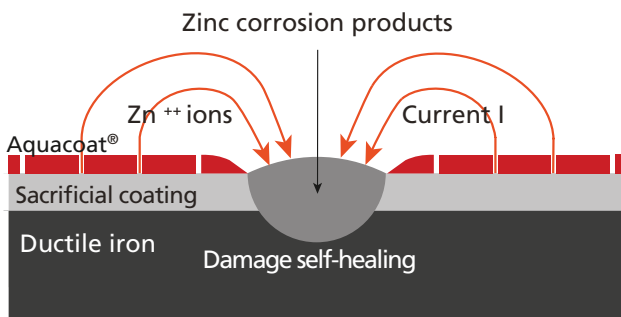

Effectiveness of protection

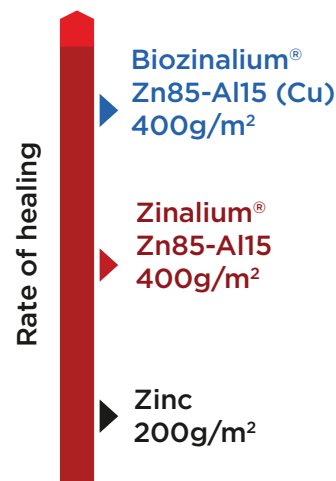

➔ **CHEMICAL RESISTANCE**

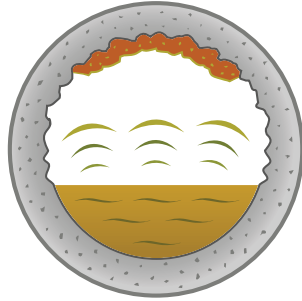

For sewerage pipelines, the danger comes mainly from the inside. Two types of nuisance are likely to affect their durability:

- the aggressiveness of certain types of waste carried,
- septic fermentations, produced by intense bacterial activity and/or inadequate ventilation.

Industrial discharges could be released accidentally into the sewerage networks. Although accidental, these discharges may nevertheless disturb the equilibria, leading to low pH levels in the effluent carried. To guarantee long-term operation of the structure, the pipeline material and type of joint chosen must cater for potential chemical hazards. The types of internal coatings (high alumina cement and epoxy) and the material of the joints guarantee safety of use and allow certain industrial applications. Please consult us.

■ **High alumina cement internal coating (INTEGRAL® range)**

Tests and practical experience have shown that high alumina cement mortars are able to withstand septic fermentation and occasional acid attacks.

■ **Epoxy on fittings**

An epoxy film is applied by dipping in a fluidised bed, or by powder coating, to coat the whole part. Consequently, its chemical resistance is at least equivalent to that of the pipes. The application process guarantees a regular deposit over the entire surface of the parts treated (average thickness: min. 250 microns).

■ **Nitrile gasket**

In contact with the effluent, the elastomer joint gaskets must withstand chemical attacks and the risks due to the presence of oils and traces of hydrocarbons.

A yellow mark indicates that it is a non food quality nitrile (NBR) gasket.

Standard EN 681.1 defines test methods and the performance to expect.

The mixture chosen by PAM is the type WG.

Product type	Internal coating type	pH range at 20 °C
TAG 32® pipes	Epoxy	4 to 12
PLUVIAL® and INTEGRAL® pipes INTEGRAL® pH1 pipes	High alumina cement Polyurethane	4 to 12 1 to 13
Fittings	Epoxy	1 to 13
Joints	NBR	1 to 13 (minerals acids and bases) 3 to 12 (organics acids and bases)

For industrial effluents, consult us.

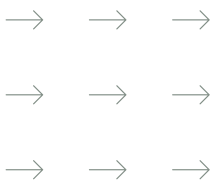

➔ **SPECIAL CASE:**
SEPTIC FERMENTATION

Some difficult operating conditions in sewerage networks as well as the long distance transport of effluent can cause changes to the quality of these effluents: septicity, production of sulphides, release of H₂S. Some accidental circumstances: high effluent temperatures and/or high sulphate content can produce the same effects and be the source of serious nuisances:

- production of offensive smells,
- risk of intoxication of operating personnel,
- corrosion of installations,
- malfunctions of wastewater treatment plants.

While it is essential to optimise the design and operation of networks to ensure installation life expectancy and protect sites, it is also important to choose a pipeline system which does not aggravate these phenomena. Furthermore, while such situations can be always be anticipated and expected, it is preferable to choose PAM pipelines with a special "High Security" polyurethane internal lining (see INTEGRAL® pH1 range).

The photographs below illustrate the damage, in particular at water line level.



CHF



Portland B



Portland A



High alumina cement

Sample number 3 shows the good performance of high alumina cement.

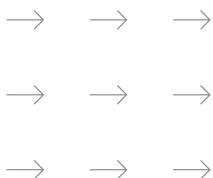

→ PRESSURE SEWER

Networks between communes may include long rising main sections to follow uneven profiles or take the shortest path. Topographic conditions requiring the installation of lift stations are followed by sewers operating under pressure.

Since the rising sections operate under pressure, a pipe with a high safety factor is required. A high quality material, capable of withstanding water hammer and pressure drops is required to cope with the high pressures encountered and the pressure variations.

The pipelines and joints therefore require excellent mechanical performance to absorb the stresses, even when faced with unexpected situations.

Saint-Gobain PAM's experience of pressurised networks, gained in water distribution, mean that INTEGRAL® system performance can be guaranteed, even at the limits of use: high pressures, water hammer, low pressures, excess pressures.

PAM pipelines can be used in rising mains up to an allowable operating pressure (PFA) more than 20 bars.

Due to the risk of sulphide formation in these sections, measures must be taken at the end of the rising main, on return to gravity flow, to limit the effects of acid attacks (H₂SO₄).

- Either by creating a suitable network or by changing the network design parameters.
- Or by using an appropriate chemical treatment (iron sulphate - oxygenation - hydrogen peroxide).
- Or by installing pipeline sections insensitive to acid attacks.



→ → →

→ → →

→ → →

■ **The INTEGRAL® pH1 range offers the advantages of an INTEGRAL® pipewith high mechanical strength and a passive anti-corrosion coating.**

The high thickness (1.5 mm for DN 80 and 2.5 mm for DN 2000) of polyurethane applied to the inside of the pipe enables the INTEGRAL® pH1 system to transport virtually all liquids encountered in industry. The seal of the polyurethane film is checked using a Holiday detector test.

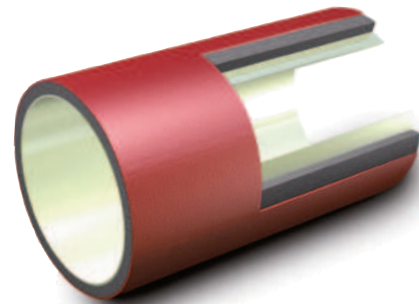

Contact our technical sales teams for these special applications.

A complete range of fittings suitable for these networks, permitted on all routes; in order to offer a complete system, Saint-Gobain PAM offers shut-off valves, gate valves and slide gate valves, as well as “waste water” air valves. *Please consult us.*

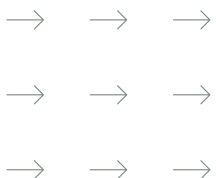

Quality and compliance with Standards!

The Saint-Gobain PAM Quality Assurance system is based on EN ISO 9001, which certifies control of production procedures (design, development, manufacture, installation and associated services, etc.).

All plants responsible for manufacturing products in the PAM range have been awarded this certification issued by an external organisation.

Saint-Gobain PAM products comply with national and international standards NF, EN and ISO.

Compliance is certified by third party organisations.

These standards define the product or service in terms of result; each product, pipe or fitting, is individually tested in the plant, during an internal pressure test.



→ PRODUCT COMPLIANCE

Specification	French or European standard	International standard
Ductile cast iron pipes, fittings and accessories and their assemblies for sewerage: recommendations and test methods	EN 598	ISO 7186
Cement mortar/epoxy internal lining	EN 598	ISO 4179
Joint gaskets – Material specification	EN 681-1	ISO 4633

→ QUALITY LABELS

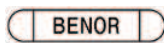

The PAM pipeline system is certified not only for compliance with French and European standards, but includes additional characteristics demonstrating suitability for function or service which are important for the decision maker.

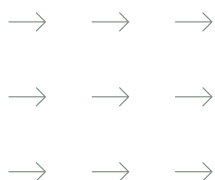



➔ PAM SAFETY CONTRACT: OUR COMMITMENT

On acceptance of the works, watertightness tests are useful, but they are not enough. For the operator, what is important that the system remains watertight over time. PAM pipelines are watertight and remain watertight. If tests reveal a loss of leaktightness within ten years of commissioning, Saint-Gobain PAM can undertake within the framework of its PAM SAFETY contract to restore leaktightness at its own expense*.

** In France and certain European Union countries.*

➔ CE MARKING

■ CE marking is:

- 1 - self declaration in three European languages, available on the Internet,
- 2 - marking affixed to sewerage products (pipes, fittings, accessories),
- 3 - product supporting documentation.



■ CE marking is:

required for all ductile cast iron pipes and fittings. The manufacturer or its authorised representative in the EEE is responsible for affixing the marking if these parts are sold within the European Union:

- pipes,
- fittings,
- accessories.

■ With Saint-Gobain PAM sewerage products, you are assured that:

- the products in the INTEGRAL®, PLUVIAL®, and TAG 32® ranges comply with dedicated European standards EN 598 / EN 15655 / EN 15189,
- the products comply with the quality labels in various European countries (NF / Kitemark / BENOR amongst others),
- the products are manufactured in ISO 9001 / ISO 14001 certified plants (quality and environmental management systems).

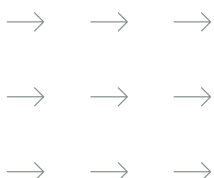

INTEGRAL®

RANGE



The ductile cast iron INTEGRAL® pipeline system, complies with EN 598 version 2009 + A1, with ISO 7186 and with the **NF** quality label, is dedicated to gravity flow and rising main sewerage systems.

Manufactured under standard ISO 9001 in plants certified ISO 14001, it consists of 6, 7 or 8 m lengths covering diameters between 80 and 2000 mm, fittings and accessories. Perfectly straight INTEGRAL® pipelines are resistant to deformities and guarantee respect of the water stream according to EN 476.

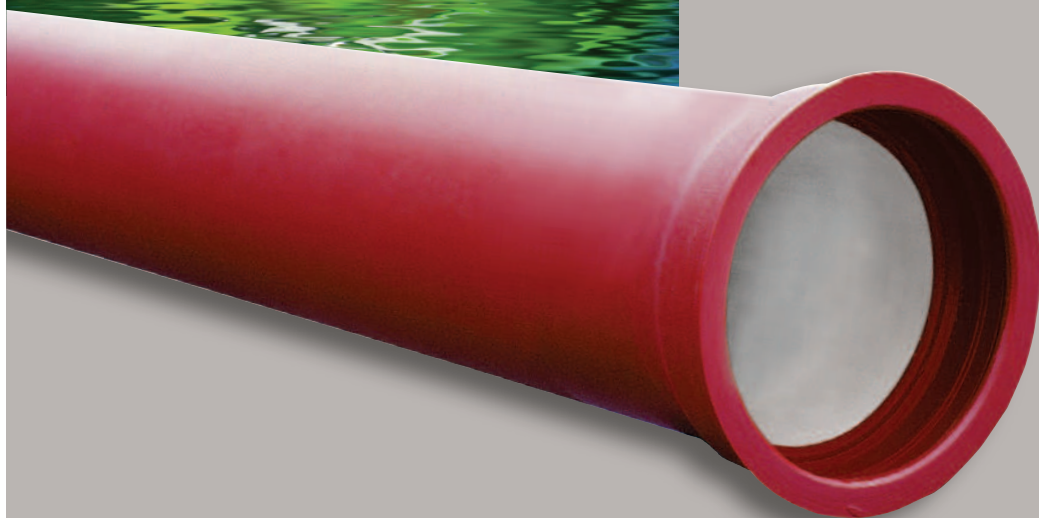



The need to regularly clean sewerage networks using a high pressure system requires high levels of performance and must be certified using a jetting test.

The remarkable mechanical characteristics of ductile cast iron limit site difficulties as well as withstanding frequent terrain movement and subsequent site works. The INTEGRAL® system allows you to achieve savings transporting spoil and during the delivery of new materials to the site. Using "natural" soil for backfill and reduced widths mean that there is less need for quarries and fewer needless lorry journeys! Consequently, CO₂ emissions, nuisance for local residents and site costs are reduced.

INTEGRAL® pipelines with the STANDARD Nitrile automatic joint system are guaranteed protection against ground movement, angular deviation, accidental excess pressure, water hammer as well as root penetration.

The external lining in ductile cast iron pipes is covered with 200 g/m² of zinc or with 400g/m² or zinc-aluminium (copper) alloy with a brown-red synthetic resin pore sealer. This combination makes INTEGRAL® pipes non porous and impermeable.

NEW :

• **ViLoK® (STANDARD Vi® NBR)**

These self-anchored joint gaskets with metal inserts (DN 80 to 700 mm) do away with the need for concrete thrust blocks, thereby reducing installation costs, in the case of pressure mains.

• **INTEGRAL® ZINALIUM®** 

The ZINALIUM® coating, a combination of 400 g/m² zinc-aluminium alloy with a brown-red pore sealer, improves the field of application of INTEGRAL® pipes in the DN 80 to 1000 range. It multiplies pipe life expectancy by three compared with a traditional lining.

• **INTEGRAL® BIOZINALIUM®**

The addition of copper in the zinc-aluminium alloy for INTEGRAL® ranges DN80 to DN600 gives a protection against biocorrosion

The mechanical qualities of the ductile cast iron material, its exceptional longevity and its recyclable character enable the INTEGRAL® system to present a remarkable environmental impact at a very low or zero maintenance cost.



INTEGRAL® RANGE: pipes

INTEGRAL BIOZINALIUM® pipe with STANDARD gasket



Field of use : gravity or under pressure
 Pipe for transportation of waste water for PH between 4 and 12.
 Internal lining : Aluminous cement.
 External coating : BioZinalium® zinc-aluminium (copper) alloy 400 g/m² + brown/red Aquacoat

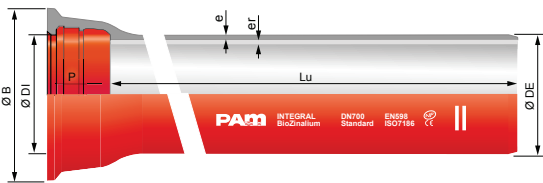
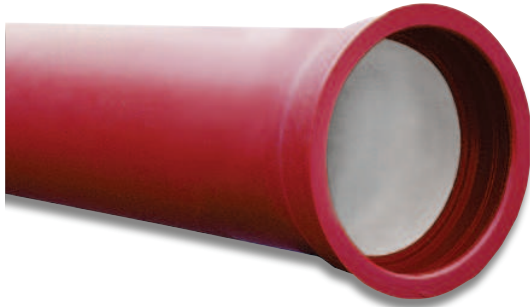

DN mm	reference	Lu m	weight kg/m	e	DE	mm			PFA bar
						DI	P	B	
80	TSA80E60BP	6.00	13.20	5.0	97.8	101.4	92.5	167.0	40
100	TSB10E60BP	6.00	16.21	5.0	117.8	121.4	94.5	188.0	40
125	TSB12S60BP	6.00	20.10	5.0	143.7	147.4	97.5	215.0	40
150	TSB15S60BP	6.00	23.88	5.0	169.7	173.4	100.5	242.0	40
200	TSB20S60BP	6.00	31.50	5.1	221.6	225.2	106.5	295.0	40
250	TSB25S60BP	6.00	41.00	5.3	273.0	276.8	105.5	352.0	38
300	TSB30S60BP	6.00	51.40	5.6	324.9	328.8	107.5	409.2	35
350	TSB35S60BP	6.00	65.60	6.0	376.8	380.9	110.5	464.2	32
400	TSB40S60BP	6.00	77.50	6.3	427.7	431.9	112.5	516.2	30
450	TSB45S60BP	6.00	91.70	6.7	478.6	483.0	115.5	574.2	29
500	TSB50S60BP	6.00	105.40	7.0	530.5	535.0	117.5	629.2	28
600	TSB60S60BP	6.00	136.90	7.7	633.3	638.1	132.5	738.5	26

(*)-E01 to be shipped with a Nitrile HR joint.
 Blue references are certified

INTEGRAL® STANDARD joint pipe



Application: gravity and pressure.
 Pipe intended to transport wastewater, for pH levels between 4 and 12.
 Internal lining: high alumina cement.
 ZINALIUM® lining: zinc-aluminium alloy 400 g/m² + brown/red epoxy.

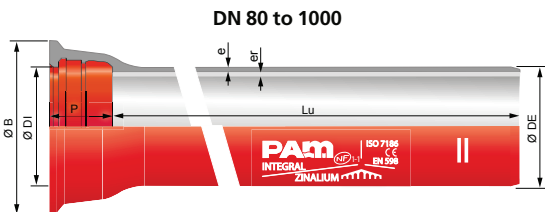

DN mm	reference (*)	Lu m	mass kg/m	th	DE	mm			AOP bar
						DI	P	B	
350	205719	6.00	65.57	6.0	376.8	380.9	110.5	464.2	32
400	205720	6.00	77.50	6.3	427.7	431.9	112.5	516.2	30
450	205731	6.00	91.70	6.7	478.6	483.0	115.5	574.2	29
500	205732	6.00	105.40	7.0	530.5	535.0	117.5	629.2	28
600	205733	6.00	136.90	7.7	633.3	638.1	132.5	738.5	26
700	234427	6.96	199.00	9.6	736.6	741.7	192.0	863.0	29
800	206666	6.95	243.60	10.4	840.4	845.8	197.0	974.0	28
900	234425	6.95	291.50	11.2	943.2	948.9	200.0	1082.0	27
1000	234426	6.96	343.10	12.0	1046.0	1052.0	203.0	1191.0	26

(*)-E01 to be shipped with a Nitrile HR joint.
 Blue references are certified



Pipe with STANDARD joint



Application: gravity and pressure.

Pipe intended to transport wastewater, for pH levels between 4 and 12.

Internal lining: high alumina cement.

External lining: zinc 200 g/m² + brown/red epoxy.



DN mm	reference (*)	Lu m	mass kg/m	mm					AOP bar
				th	DE	DI	P	B	
700	TSB70E69	6.96	199.00	9.6	736.6	741.7	192.0	863.0	29
800	TSB80E69	6.95	243.60	10.4	840.4	845.8	197.0	974.0	28
900	TSB90E69	6.95	291.50	11.2	943.2	948.9	200.0	1082.0	27
1000	TSC10E69	6.96	343.10	12.0	1046.0	1052.0	203.0	1191.0	26
1100	TSC11N79	8.19	440.00	14.4	1148.8	1155.1	225.0	1300.0	29
1200	TSC12N79	8.19	507.60	15.3	1252.3	1260.0	235.0	1412.5	29
1400	TSC14N80	8.17	678.90	17.1	1458.9	1467.9	245.0	1592.1	28
1500	TSC15N80	8.16	764.70	18.0	1561.7	1571.1	265.0	1709.8	27
1600	TSC16N80	8.16	851.30	18.9	1664.5	1674.2	265.0	1815.9	27
1800	TSC18N80	8.15	1036.20	20.7	1871.1	1881.5	275.0	2032.2	27
2000	TSC20N80	8.13	1242.20	22.5	2077.7	2088.8	290.0	2259.0	26

(*) -E01 to be shipped with a Nitrile HR joint.

Blue references are certified

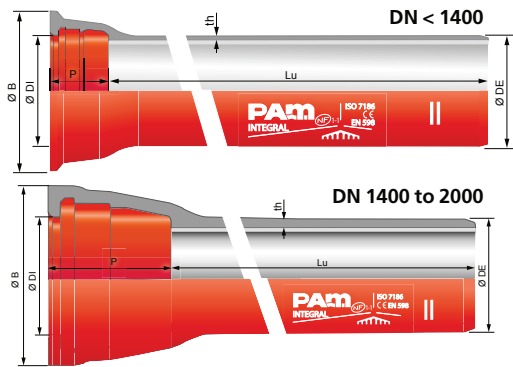
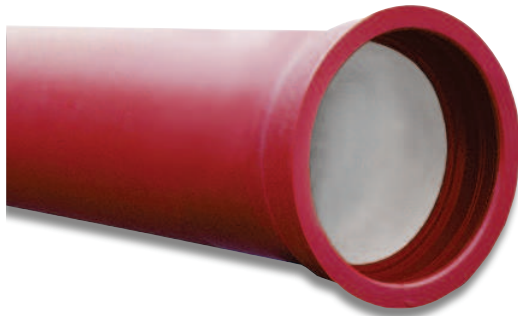

pH1 pipe with STANDARD joint



Application: gravity and pressure.

Pipe intended to transport highly aggressive effluents, for pH levels between 1 and 13.

Internal lining: polyurethane.

External lining: zinc 200 g/m² + brown/red epoxy.



DN mm	reference (*)	Lu m	mass kg/m	mm					AOP bar
				th	DE	DI	P	B	
150	TSB15S60VB	6.00	20.50	5.0	169.7	173.4	100.5	242.0	40
200	TSB20S60VB	6.00	27.10	5.0	221.6	225.2	106.5	295.0	40
250	TSB25S60VB	6.00	35.50	5.3	273.0	276.8	105.5	352.0	38
300	TSB30S60VB	6.00	44.60	5.6	324.9	328.8	107.5	409.2	35
350	TSB35S60VB	6.00	55.20	6.0	376.8	380.9	110.5	464.2	32
400	TSB40S60VB	6.00	65.40	6.3	427.7	431.9	112.5	516.2	30
450	TSB45S60VB	6.00	78.10	6.7	478.6	483.0	115.5	574.2	29
500	TSB50S60VB	6.00	90.50	7.0	530.5	535.0	117.5	629.2	28
600	TSB60S60VB	6.00	118.80	7.7	633.3	638.1	132.5	738.5	26
700	TSB70E69VB	6.96	172.30	9.6	736.6	741.7	192.0	863.0	29
800	TSB80E69VB	6.95	213.10	10.4	840.4	845.8	197.0	974.0	28
900	TSB90E69VB	6.95	257.20	11.2	943.2	948.9	200.0	1082.0	27
1000	TSC10E69VB	6.96	305.00	12.0	1046.0	1052.0	203.0	1191.0	26
1100	TSC11N79VB	8.19	440.00	14.4	1148.8	1155.1	225.0	1300.0	29
1200	TSC12N79VB	8.19	463.80	15.3	1252.3	1260.0	235.0	1412.5	29
1400	TSC14N80VB	8.17	596.20	17.1	1458.9	1467.9	245.0	1592.1	28
1500	TSC15N80VB	8.16	676.10	18.0	1561.7	1571.1	265.0	1709.8	27
1600	TSC16N80VB	8.16	758.70	18.9	1664.5	1674.2	265.0	1815.9	27
1800	TSC18N80VB	8.15	932.00	20.7	1871.1	1881.5	275.0	2032.2	27
2000	TSC20N80VB	8.13	1126.40	22.5	2077.7	2088.8	290.0	2259.0	26

(*) -E01 to be shipped with a Nitrile HR joint.

For DN 80 to 125 : please consult us.



INTEGRAL® RANGE: pipes for special purposes

TT PE All Terrain Pipe



Application: gravity and pressure.

Pipe designed for cases of extreme corrosion in the surrounding environment, requiring special external protection.

External lining: polyethylene.

Internal lining: high alumina cement.

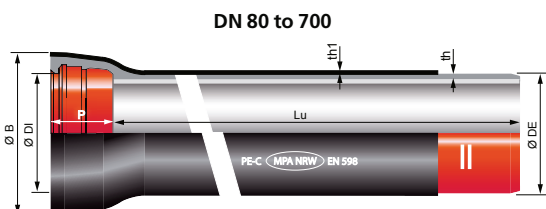

DN mm	reference (*)	Lu m	mass kg/m	th	th1	DE	DI	P	Ø B
				mm					
80	TSB80S60BG	6.00	13.50	4.8	1.8	97.8	101.4	92.5	147.0
100	TSB10S60BG	6.00	19.00	4.8	1.8	117.8	121.4	94.5	168.0
125	TSB12S60BG	6.00	20.30	4.8	2.0	143.7	147.4	97.5	195.0
150	TSB15S60BG	6.00	23.50	4.8	2.0	169.7	173.4	100.5	222.0
200	TSB20S60BG	6.00	32.30	4.9	2.0	221.6	225.2	106.5	279.0
250	TSB25S60BG	6.00	42.20	5.3	2.0	273.0	276.8	105.5	334.0
300	TSB30S60BG	6.00	53.00	5.6	2.2	324.9	328.8	107.5	392.0
350	TSB35S60BG	6.00	69.00	6.0	2.2	376.8	380.9	110.5	446.0
400	TSB40S60BG	6.00	81.30	6.3	2.2	427.7	431.9	112.5	499.5
450	TSB45S60BG	6.00	95.20	6.7	2.2	478.6	483.0	115.5	554.0
500	TSB50S60BG	6.00	111.00	7.0	2.5	530.5	535.0	117.5	608.6
600	TSB60S60BG	6.00	141.00	7.7	2.5	633.3	638.0	132.5	718.0
700	TSB70E60BG	6.00	206.00	9.6	2.5	736.6	741.7	192.0	830.0

(*) -E01 to be shipped with a Nitrile HR joint.

INTEGRAL® ISOPAM pipe



Application: gravity and pressure.

Pipe designed to protect effluents from freezing.

Laid above ground (bridge crossings, etc.).

External lining: polyurethane foam

Internal lining: high alumina cement.

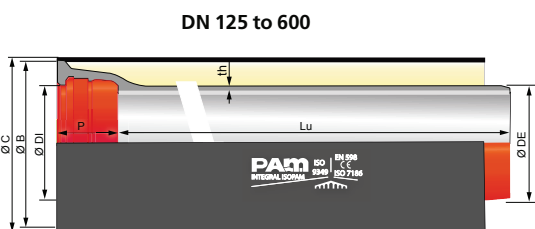

DN mm	reference (*)	Lu m	mass kg/m	th	DE	DI	P	B	C	AOP bar
				mm						
125	Please consult us	6.00	28.40	5.0	143.7	147.4	98.5	215.0	225.0	40
150	TSB15S60BJ	6.00	28.70	5.0	169.7	173.4	100.5	242.0	250.0	40
200	TSB20S60BJ	6.00	38.90	5.0	221.6	225.2	106.5	295.0	315.0	40
250	TSB25S60BJ	6.00	53.30	5.3	273.0	276.8	105.5	352.0	400.0	38
300	TSB30S60BJ	6.00	66.10	5.6	324.9	328.8	107.5	409.2	450.0	35
400	TSB40S60BJ	6.00	99.20	6.3	427.7	431.9	112.5	516.2	560.0	30
500	TSB50S60BJ	6.00	134.80	7.0	530.5	535.0	117.5	629.2	670.0	28
600	TSB60S60BJ	6.00	179.20	7.7	633.3	638.1	132.5	738.5	800.0	26

(*) -E01 to be shipped with a Nitrile HR joint.



PUX All Terrain Pipe



Application: gravity and pressure.

Pipe designed for cases of extreme corrosion in the surrounding environment, requiring special external protection.

External lining: polyurethane.

Internal lining: high alumina cement.

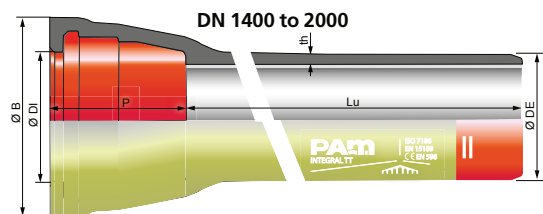
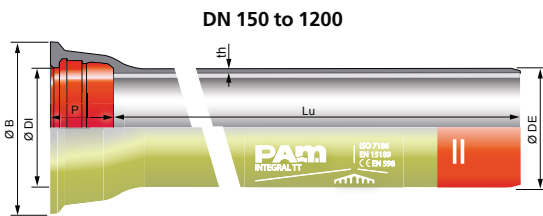

DN mm	reference (*)	Lu m	mass kg/m	th	DE	DI	P	B	AOP bar
				mm					
150	TSB15S60BH	6.00	23.58	5.0	169.7	173.4	100.5	242.0	40
200	TSB20S60BH	6.00	31.20	5.0	221.6	225.2	106.5	295.0	40
250	TSB25S60BH	6.00	40.63	5.3	273.0	276.8	105.5	352.0	38
300	TSB30S60BH	6.00	50.83	5.6	324.9	328.8	107.5	409.2	35
350	TSB35S60BH	6.00	66.36	6.0	376.8	380.9	110.5	464.2	32
400	TSB40S60BH	6.00	78.13	6.3	427.7	431.9	112.5	516.2	30
450	TSB45S60BH	6.00	92.40	6.7	478.6	483.0	115.5	574.2	29
500	TSB50S60BH	6.00	106.41	7.0	530.5	535.0	117.5	629.2	28
600	TSB60S60BH	6.00	137.91	7.7	633.3	638.1	132.5	738.5	26
700	TSB70E69BH	6.96	202.50	9.6	736.6	741.7	192.0	863.0	29
800	TSB80E69BH	6.95	243.60	10.4	840.4	845.8	197.0	974.0	28
900	TSB90E69BH	6.95	295.90	11.2	943.2	948.9	200.0	1082.0	27
1000	TSC10E69BH	6.96	348.00	12.0	1046.0	1052.0	203.0	1191.0	26
1100	TSC11N79BH	8.19	440.00	14.4	1148.8	1155.1	225.0	1300.0	29
1200	TSC12N79BH	8.19	513.20	15.3	1252.3	1260.0	235.0	1412.5	29
1400	TSC14N80BH	8.17	685.70	17.1	1458.9	1467.9	245.0	1592.1	28
1600	TSC16N80BH	8.16	859.10	18.9	1664.5	1674.2	265.0	1815.9	27
1800	TSC18N80BH	8.15	1045.10	20.7	1871.1	1881.5	275.0	2032.2	27
2000	TSC20N80BH	8.13	1252.00	22.5	2077.7	2088.8	290.0	2259.0	26

(*) -E01 to be shipped with a Nitrile HR joint.





INTEGRAL® RANGE: gravity connections - branch connections

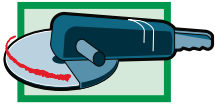

Rectangular hole
(cross cutting)

67°30 saddle branch

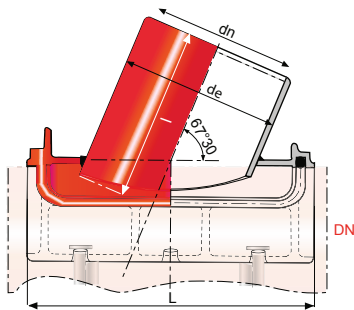

sewer DN mm	branch dn mm	reference	mass kg	L	de	W
				mm		
400	150	TUB40PS0J	32.00	400.0	170.0	320.0
	200	TUB40PS0K	35.50	400.0	222.0	320.0
	250	TUB40PS0L	36.00	400.0	273.0	320.0
500	150	TUB50PS0J	35.70	400.0	170.0	352.0
	200	TUB50PS0K	35.70	400.0	222.0	352.0
	250	TUB50PS0L	39.70	400.0	273.0	352.0
600	150	TUB60PS0J	40.40	400.0	170.0	350.0
	200	TUB60PS0K	41.40	400.0	222.0	350.0
	250	TUB60PS0L	43.40	400.0	273.0	350.0

Gasket, 2 stirrups and bolts included.
Blue references are certified

90° saddle branch

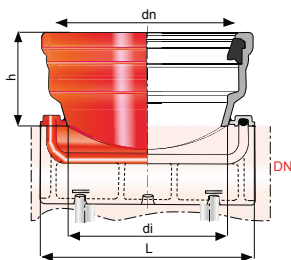

sewer DN mm	branch dn mm	reference	mass kg	L	di	h
				mm		
400	300	TSB40PTOM	46.00	400.0	268.0	174.0
500	300	TSB50PTOM	53.00	400.0	275.0	175.0
600	300	TSB60PTOM	56.00	400.0	278.0	176.0

Saddle gasket, standard gasket, 2 stirrups and bolts included.
Blue references are certified



See mixed rectangular or circular hole saddle branches on TAG 32® or INTEGRAL® pipes on page 64.



INTEGRAL® RANGE: gravity connections - branch connections



Circular hole
(coring)

For round cuts you need:

- GÖLZ, NORTON or similar type core drill (speed approx. 60 m/min),
 - hole saw for cast iron (Ø 172 mm for DN 150 and Ø 232 mm for DN 200) also see accessories,
 - site drill
 - Ø 13 mm bit (tungsten carbide tip for hardened steel and abrasive materials) also see accessories.
- For more information, contact our Regional Managements.

Round saddle swivel branch

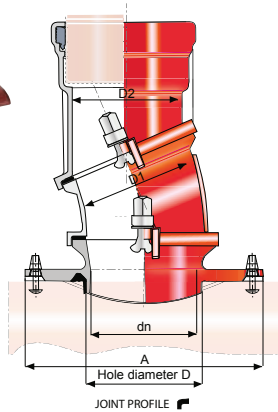

sewer DN mm	branch dn mm	reference	mass kg	A	D
				mm	
250 and 300	125	TJB25AR0G	18.40	338.0	172.5 ± 1
250 and 300	150	TJB25AR0J	21.40	338.0	172.5 ± 1
350 to 600	125	TJB40AR0G	19.00	338.0	172.5 ± 1
350 to 600	150	TJB40AR0J	20.60	338.0	172.5 ± 1
400	200	TJB40AR0K	27.00	395.0	232.5 ± 1
450 to 600	200	TJB45AR0K	26.30	395.0	232.5 ± 1
700 to 1200	150	TJB70AR0J	19.90	338.0	172.5 ± 1
700 to 800	200	TJB70AR0K	25.60	395.0	232.5 ± 1
900 to 1200	200	TJB90AR0K	25.10	395.0	232.5 ± 1

Blue references are certified

90° saddle branch

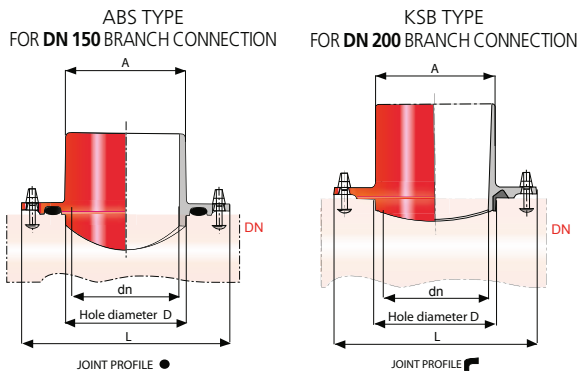

sewer DN mm	branch dn mm	reference	mass kg	A	D	L
				mm		
250	150	TUB25SR0J	10.00	168.0	172.5 ± 1	290.0
300		TUB30SR0J	9.70	168.0	172.5 ± 1	290.0
350 and 400		TUB40SR0J	10.00	168.0	172.5 ± 1	290.0
450 to 600		TUB45SR0J	10.00	168.0	172.5 ± 1	290.0
700 to 1200		TUB70SR0J	7.60	168.0	172.5 ± 1	290.0
300	200	TUB30SR0K	13.00	217.5	232.5 ± 1	340.0
350		TUB35SR0K	12.50	217.5	232.5 ± 1	340.0
400		TUB40SR0K	13.00	217.5	232.5 ± 1	340.0
450 to 600		TUB45SR0K	11.10	217.5	232.5 ± 1	340.0
700 and 800		TUB70SR0K	13.00	217.5	232.5 ± 1	340.0
900 to 1200		TUB90SR0K	10.00	217.5	232.5 ± 1	340.0

Blue references are certified

90° cast iron branch connection to concrete sewer

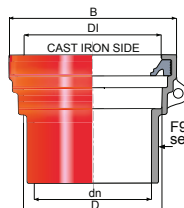

sewer DN mm	branch dn mm	reference	mass kg	B	DI	D
				mm		
Wall thickness ≥ 60	150	TJB15FR	6.50	212.0	173.2	175.0
	200	TJB20FR	9.40	266.0	225.2	228.0

Blue references are certified



67°30 angle branch, spigot on double socket

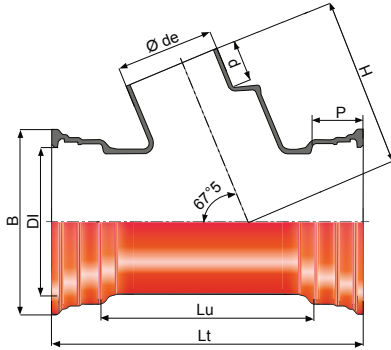

DN mm	reference with 2 standards joints	mass kg	for 2 main sockets					for 1 67°30 spigot			
			DI min.	P	Lt	Lu	B	dn	de max.	p	H
			mm					mm			
250	TJB25UF0G	56.00	275.5	105.0	579.0	369.0	351.0	125	145.5	90.0	342.0
	TJB25UF0J	57.00	275.5	105.0	579.0	369.0	351.0	150	171.5	90.0	342.0
	TJB25UF0K	58.00	275.5	105.0	579.0	369.0	351.0	200	223.5	90.0	342.0
300	TJB30UF0G	78.50	327.5	110.0	687.0	467.0	408.0	125	145.5	90.0	380.0
	TJB30UF0J	78.50	327.5	110.0	687.0	467.0	408.0	150	171.5	90.0	380.0
	TJB30UF0K	79.50	327.5	110.0	687.0	467.0	408.0	200	223.5	90.0	380.0
	TJB30UF0L	80.50	327.5	110.0	687.0	467.0	408.0	250	275.0	105.0	380.0

Standard HR joint included.
Blue references are certified

67°30 angle branch, 3 spigots

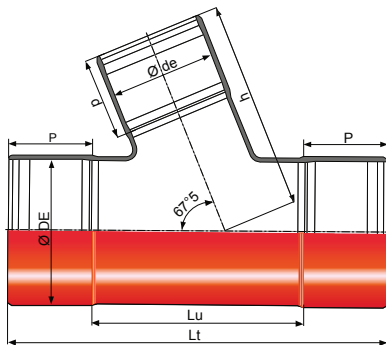
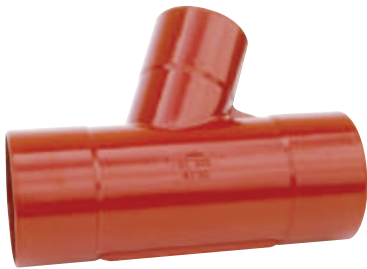

DN mm	reference	mass kg	for 2 main spigots				for 1 67°30 spigot			
			DE max. coated	P	Lt	Lu	dn	de max. coated	p	h
			mm				mm			
150	TUB15TF0G	17.40	171.5	113.0	493.0	267.0	125	145.5	120.0	270.0
200	TUB20TF0G	25.80	223.5	124.0	568.0	320.0	125	145.5	120.0	310.0
	TUB20TF0J	26.20	223.5	124.0	568.0	320.0	150	171.5	120.0	310.0
250	TUB25TF0G	42.00	273.0	98.0	565.0	369.0	125	144.0	120.0	342.0
	TUB25TF0J	43.50	273.0	98.0	565.0	369.0	150	170.0	120.0	342.0
	TUB25TF0K	44.50	273.0	98.0	565.0	369.0	200	222.0	120.0	342.0
300	TUB30TF0G	62.00	325.0	106.5	680.0	467.0	125	144.0	120.0	380.0
	TUB30TF0J	62.00	325.0	106.5	680.0	467.0	150	170.0	120.0	380.0
	TUB30TF0K	63.00	325.0	106.5	680.0	467.0	200	222.0	120.0	380.0
	TUB30TF0L	64.00	325.0	106.5	680.0	467.0	250	273.0	120.0	380.0

Blue references are certified





GGs Sewerage joint

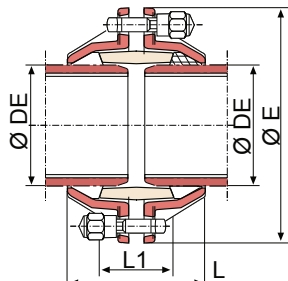

DN mm	reference	mass kg	AOP bar	DE min.	DE max.	Approx. L	L1	E
				mm				
80	TXA80MG	4.90	40	97.0	100.0	127.0	60.0	213.0
100	TXB10MG	6.60	40	117.0	120.0	133.0	65.0	233.0
125	TXB12MG	7.60	25	143.0	146.0	140.0	70.0	259.0
150	TXB15MG	8.80	25	168.0	172.0	145.0	75.0	287.0
200	TXB20MG	12.80	25	220.0	223.0	153.0	80.0	342.0
250	TXB25MG	18.10	25	272.0	275.0	164.0	90.0	403.0
300	TXB30MG	22.90	25	323.0	327.0	170.0	95.0	457.0
350	TXB35MG	29.00	16	375.0	379.0	183.0	100.0	511.0
400	TXB40MG	34.80	16	426.0	430.0	185.0	100.0	564.0
450	TXB45MG	39.70	16	477.0	481.0	192.0	105.0	617.0
500	TXB50MG	47.80	16	529.0	533.0	193.0	105.0	671.0
600	TXB60MG	61.20	16	631.0	636.0	200.0	110.0	777.0

Tylon NBR joints included.
Can be used for pressure sewer networks

Connection sleeve

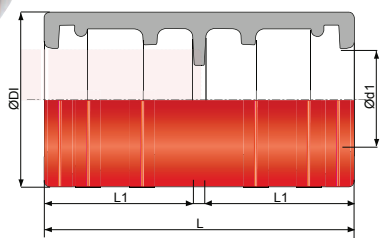

DN mm	reference	mass kg	AOP bar	DI	Ø d1	L1	L
				mm			
150	107639	8.00	40	207.0	170.0	75.0	158.0
200	107604	11.50	40	262.0	222.0	80.0	168.0
250	107603	14.50	38	315.0	274.0	86.0	180.0
300	107605	20.00	35	371.0	326.0	95.0	200.0
400	TJB40ML	32.00	30	479.0	429.0	100.0	210.0
500	TJB50ML	45.00	28	587.0	532.0	107.0	224.0
600	TJB60ML	56.00	26	695.0	635.0	120.0	250.0
700	TJB70ML	97.00	29	808.0	738.0	145.0	300.0
800	TJB80ML	128.00	28	917.0	842.0	155.0	320.0
900	Please consult us	-	27	1026.0	945.0	167.0	344.0

Tylon NBR joints included.

Multi material sleeve collars for gravity sewage network

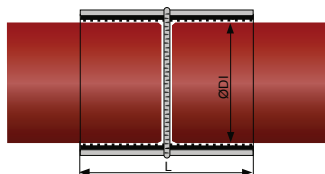

DN mm	Plage Ø DI acceptable mm	reference	mass kg	L mm
150	160 => 192	TJB15MV	1.650	151
200	200 => 261	TJB20MV	2.700	176
250	250 => 324	TJB25MV	3.250	176
300	313 => 382	TJB30MV	5.380	215

(*) DN200 + DN250: delivered with an additional eccentric ring to maintain the gravity flow in case of connexion with plastic pipes with an external diameter of 200 mm or 300 mm



INTEGRAL® RANGE: gravity connections - branch connections and manhole collars

Joint for connection to concrete manhole

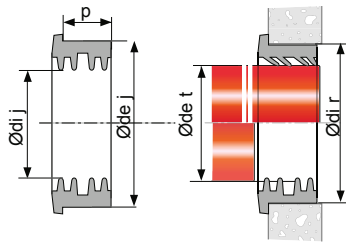

DN mm	reference	mass kg	F910 joint				Type Art no.	pipe	manhole cover
			outer Ø j	inner Ø di j	wid P	outer Ø de t		inner Ø di r	
			mm					mm	
125	144170	0.35	176.0	136.0	50.0	1815600	143.7	168.0 ± 1.5	
150	144171	0.40	202.0	162.0	50.0	1568201	172.0	194.0 ± 2.0	
200	158311	0.50	255.0	215.0	50.0	1568306	222.0	245.0 ± 2.0	
250	184951	0.50	309.0	269.0	50.0	1813403	274.0	296.0 ± 1.5	
300	158312	0.55	365.0	319.0	50.0	1126803	326.0	354.0 ± 2.0	

For the hole DN, please consult us.

Standard joint manhole collar

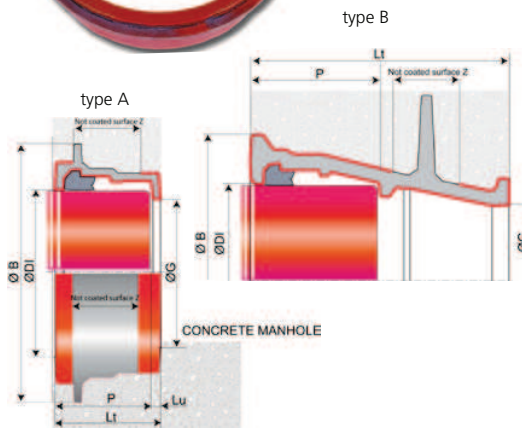

DN mm	Type	reference with joints	Mass kg	Ø DI	P	Lu	Lt	Ø B	Ø G	Z
150	A	TSB15MS	5.01	173.0	90	10	100	256	154	65
200	A	TSB20MS	6.43	225.0	90	10	100	309	204	64.5
250	A	TSB25MS	8.66	277.0	100	10	110	362	255	74
300	A	TSB30MS	10.39	329.0	100	10	110	417	306	74
350	A	TSB35MS	13.10	381.0	100	10	110	473	356	74
400	A	TSB40MS	14.73	432.0	100	10	110	525	406	74
450	A	TSB45MS	25.00	481.0	102	10	112	579	465	62
500	A	TSB50MS	21.44	533.0	100	10	110	632	515	64
600	A	TSB60MS	26.71	636.0	110	10	120	738	615	66
700	A	TSB70MS	37.08	739.5	150	10	160	845	720	105
800	A	TSB80MS	53.00	843.5	150	10	160	950	820	106
900	A	TSB90MS	63.21	946.5	165	10	175	1055	925	118
1000	A	TSC10MS	73.51	1049.5	175	10	185	1160	1025	130
1200	B	TSC12MS	421.00	1256.6	195	-	415	1530	1200	150
1400	A	TSC14MS	385.00	1463.6	255	25	-	1755	1411	150
1600	A	TSC16MS	477.00	1669.6	275	25	-	1975	1613	150
1800	A	TSC18MS	612.00	1876.6	258	62	-	2195	1827	150
2000	A	TSC20MS	980.00	2083.6	290	50	340	2425	2030	150

Standard HR joint included.
Blue references are certified

STANDARD HR joint gasket

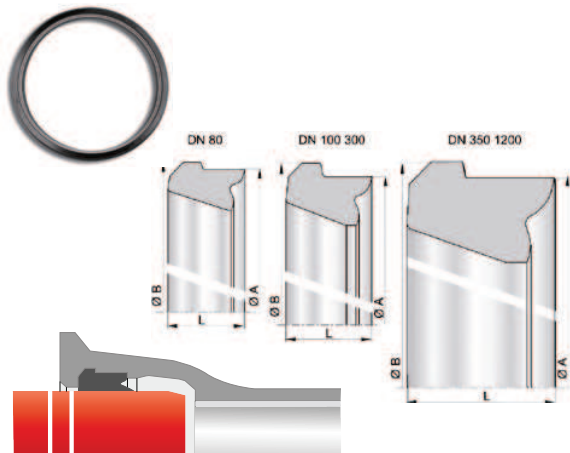

DN mm	reference	mass kg	L	A	B
			mm		
80	JSB80BB	0.16	29.8	127.5	135.7
100	JSB10BB	0.21	29.8	148.6	158.6
125	JSB12BB	0.26	30.6	175.7	185.7
150	JSB15BB	0.30	30.6	202.1	212.1
200	JSB20BB	0.41	31.7	250.5	260.5
250	JSB25BB	0.52	32.6	303.5	313.5
300	JSB30BB	0.75	35.9	359.5	369.5
350	JSB35BB	0.95	37.8	414.0	422.0
400	JSB40BB	1.13	38.8	466.5	474.5
450	JSB45BB	1.39	40.7	519.8	527.8
500	JSB50BB	1.63	41.8	573.4	581.4
600	JSB60BB	2.28	45.0	680.2	690.2
700	JSB70BB	3.02	48.2	787.6	797.6
800	JSB80BB	3.86	51.4	895.4	905.4
900	JSB90BB	4.85	54.6	1002.3	1012.3
1000	JSC10BB	5.99	57.8	1109.1	1119.1
1200	JSC12BB	9.83	68.2	1326.2	1338.2
1400	JSC14BB	16.30	81.6	1546.4	1554.9
1500	JSC15BB	20.81	89.2	1656.6	1675.6
1600	JSC16BB	22.15	89.2	1761.4	1780.4
1800	JSC18BB	29.18	96.6	1977.0	1998.0
2000	JSC20BB	33.00	104.6	2204.8	2226.8

ANGULAR DEFLECTIONS

DN	Pipes	Fittings
80 to 300	5°	4.5°
350 to 600	4°	3.5°
700 to 1200	4°	2.5°
1400 to 1600	3°	2.5°
1800	2.5°	2°
2000	2	1.5°



Access hatch (*)

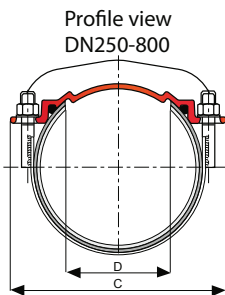
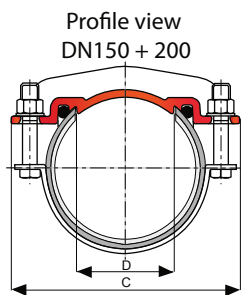
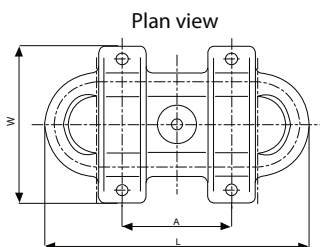

DN mm	reference consisting of 1 hatch + 2 threaded stirrups with nuts fitted + 1 O-ring	mass kg	L	W	A	C	D (**)	joint outer Ø
			mm					
150	TXB15PA	7.50	411.0	244.0	170.0	244.0	107.0	307.5
200	TXB20PA	9.20	446.0	280.0	170.0	280.0	142.0	344.0
250	TXB25PA	17.00	700.0	350.0	350.0	350.0	172.0	522.0
300	TXB30PA	20.00	740.0	400.0	350.0	400.0	212.0	561.0
400	TXB40PA	18.00	740.0	400.0	350.0	400.0	212.0	556.0
500	TXB50PA	17.80	740.0	400.0	350.0	400.0	212.0	556.0
600	TXB60PA	28.50	722.0	520.0	350.0	520.0	290.0	570.0
700	TXB70PA	29.50	722.0	520.0	350.0	520.0	290.0	570.0
800	TXB80PA	30.00	722.0	520.0	350.0	520.0	290.0	570.0

(*) Attachment with stirrups. (**) Drill diameter.

Cleaning tee



DN mm	dn mm	reference (including 3 IM joints)	mass kg	Lu	L	DI	B	P	Hu
				mm					
400	150	TJB15PD0J-E00	63.00	514.0	694.0	175.0	219.0	90.0	289.0
400	200	TJB20PD0K-E00	67.00	475.0	655.0	226.0	273.0	90.0	289.0
400	250	TJB25PD0L-E00	75.00	521.0	721.0	283.5	317.0	100.0	283.0
400	300	TJB30PD0M-E00	80.00	455.0	675.0	337.5	386.0	110.0	283.0

Connecting joints included.
Blue references are certified

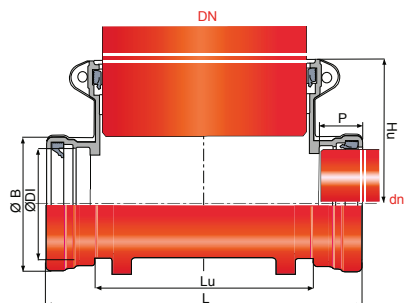

Inspection tee with cover

With counterweight

DN mm	dn mm	reference (inclusive)	mass kg	Lu	L	DI	B	P	Hu
				mm					
400	150	TJB15PD0J-E07	74.50	514.0	694.0	175.0	219.0	90.0	289.0
400	200	TJB20PD0K-E07	76.50	475.0	655.0	226.0	273.0	90.0	289.0
400	250	TJB25PD0L-E07	84.50	521.0	721.0	283.5	317.0	100.0	283.0
400	300	TJB30PD0M-E07	89.50	455.0	675.0	337.5	386.0	110.0	283.0

Connecting joints included.
Blue references are certified

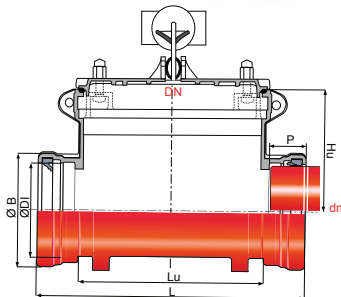
Without counterweight

DN mm	dn mm	reference (inclusive)	mass kg	Lu	L	DI	B	P	Hu
				mm					
400	150	TJB15PD0J-E06	66.00	514.0	694.0	175.0	219.0	90.0	289.0
400	200	TJB20PD0K-E06	67.50	475.0	655.0	226.0	273.0	90.0	289.0
400	250	TJB25PD0L-E06	75.00	521.0	721.0	283.5	317.0	100.0	283.0
400	300	TJB30PD0M-E06	79.50	455.0	675.0	337.5	386.0	110.0	283.0

Connecting joints included.
Blue references are certified

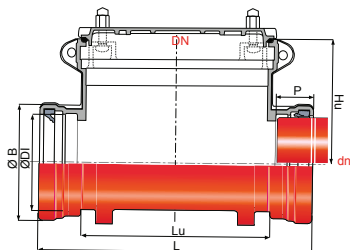
Cover only

Sewer DN mm	reference	mass kg	for inspection tee
400	TJB15PU	17.00	without counterweight
400	TJB15PR	25.00	without counterweight

Welded inlet

These welded inlets are manufactured on request on INTEGRAL® pipes. When ordering, please state the exact position of the inlet in relation to the pipe socket. *Please consult us.*



Leaktight cleaning chamber

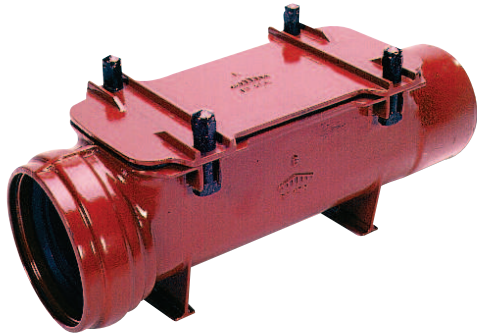

DN	A x B mm	reference	mass kg	L	P	DI	DE	h
				mm				
150	400x150	TJB15BJ	19.00	615.0	87.0	175.0	170.0	113.0
200	400x200	TJB20BJ	28.50	632.0	88.0	225.0	222.0	155.0

Fitted upstream of an IM joint
Blue references are certified

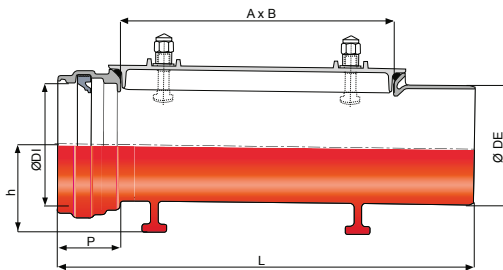

Leaktight cleaning chamber with flanges (for pressure sewers)

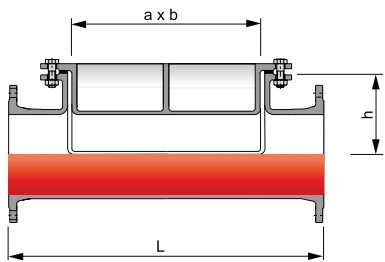

DN mm	reference		mass kg	a	b	h	L
	PN10	PN16		mm			
80		102513	37.50	250.0	80.0	72.0	500.0
100		102514	47.50	250.0	100.0	82.0	500.0
125		102566	65.00	300.0	125.0	95.0	550.0
150		102515	80.00	290.0	152.0	115.0	550.0
200	102516	Please consult us	113.00	330.0	202.0	150.0	650.0
250	102517	Please consult us	167.00	360.0	253.0	190.0	700.0
300	102518	Please consult us	215.00	400.0	304.0	219.0	750.0
400	102519	Please consult us	350.00	480.0	404.0	277.0	900.0
500	104672	Please consult us	390.00	550.0	504.0	342.0	900.0

Weight of fitting without joint.
Flat gasket, bolts, screws and nuts (galvanised) included.



INTEGRAL® RANGE: pressure sewer fittings

Due to the significant overpressures experienced by pressure sewers (water hammer - cavitation - air pockets), specific fittings are required. Most of these parts are fitted with an automatic joint and protected by epoxy powder coating. They are guaranteed to withstand a pressure of 9 bar.

Taper with two sockets and STANDARD joint

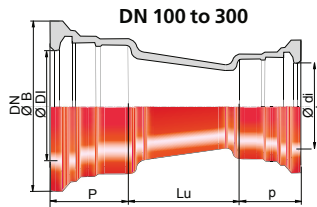
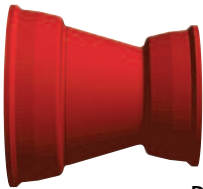

DN 100 to 300

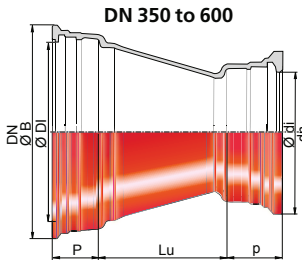

DN 350 to 600

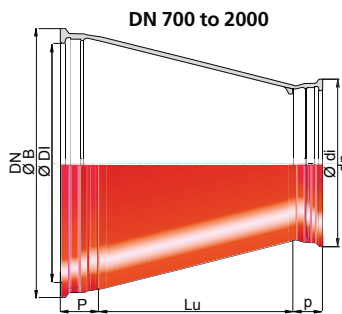

DN 700 to 2000

DN mm	dn mm	reference	mass kg	Lu	P	mm			
						DI	B	p	di
100	80	TSB10VE0E	7.50	104.5	88.0	121.0	187.5	85.0	101.0
125	100	TSB12VE0F	9.40	105.5	91.0	147.0	214.5	88.0	121.0
150	100	TSB15VE0F	11.10	130.0	94.0	173.0	241.0	88.0	121.0
200	150	TSB20VE0J	16.70	125.0	100.0	225.0	294.0	94.0	173.0
250	200	TSB25VE0K	25.30	125.0	105.0	277.0	351.0	100.0	225.0
300	200	TSB30VE0K	35.70	222.0	110.0	329.0	408.0	100.0	225.0
	250	TSB30VE0L	35.90	123.0	110.0	329.0	408.0	105.0	277.0
350	300	TSB35VE0M	55.00	187.0	110.0	381.4	464.3	110.0	329.0
400	300	TSB40VE0M	60.00	260.0	112.0	432.4	515.3	110.0	329.0
500	400	TSB50VE0N	86.50	290.0	117.5	535.5	628.0	112.0	432.4
600	500	TSB60VE0Q	120.00	258.0	132.5	638.6	737.0	117.5	535.5
700	500	SSB70VE0QFF	198.00	480.0	150.0	742.2	861.0	120.0	535.0
	600	TSB70VE0R (*)	176.00	267.5	150.0	742.2	861.0	120.0	638.0
800	600	TSB80VE0R (*)	255.00	467.5	160.0	846.3	972.0	120.0	638.0
	700	TSB80VE0S (*)	243.00	280.0	160.0	846.3	972.0	150.0	742.2
900	700	SSB90VE0SFF	338.00	480.0	175.0	949.4	1080.0	150.0	742.2
	800	SSB90VE0TFF	307.00	280.0	175.0	949.4	1080.0	160.0	846.3
1000	800	SSC10VE0TFF	417.00	480.0	185.0	1052.5	1189.0	160.0	846.3
	900	SSC10VE0UFF	378.00	280.0	185.0	1052.5	1189.0	175.0	949.4
1200	1000	SSC12VE0VFF	543.00	480.0	195.0	1263.0	1412.0	185.0	1052.5
1400	1200	SSC14VE0BFF	714.00	360.0	255.0	1467.0	1600.0	195.0	1263.0
1500	1200	SSC15VE0BFF	824.00	410.0	280.0	1570.0	1742.0	195.0	1263.0
	1400	Please consult us	795.00	100.0	280.0	1570.0	1742.0	255.0	1467.0
1600	1200	SSC16VE0BFF	1065.00	645.0	275.0	1673.0	1820.0	195.0	1263.0
	1400	SSC16VE0CFF	1009.00	350.0	275.0	1673.0	1820.0	255.0	1467.0
1500	Please consult us	1187.00	400.0	275.0	1673.0	1820.0	280.0	1570.0	
1800	1600	Please consult us	1267.00	427.0	258.0	1881.7	2038.0	275.0	1673.0
2000	1800	Please consult us	1776.00	472.0	290.0	2089.0	2269.0	258.0	1881.7

Standard Nitrile joint included up to DN 600. DN 700 to 2000, joint not included except (*).
Blue references are certified

Tee with three sockets and STANDARD joint

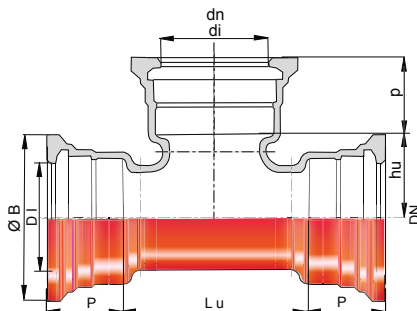

DN mm	dn mm	reference	mass kg	Lu	P	mm				
						DI	B	hu	p	di
80	80	TSA80TE0E	11.70	183.0	85.0	101.0	167.5	91.5	85.0	101.0
100	80	TSB10TE0E	13.90	185.0	88.0	131.0	187.5	103.5	85.0	101.0
	100	TSB10TE0F	15.50	210.0	88.0	131.0	187.5	105.0	88.0	121.0
125	80	TSB12TE0E	16.20	165.0	91.0	147.0	214.5	121.5	85.0	101.0
	100	TSB12TE0F	17.60	190.0	91.0	147.0	214.5	125.0	88.0	121.0
125	125	TSB12TE0G	21.80	267.0	91.0	147.0	214.5	133.5	91.0	147.0
150	100	TSB15TE0F	20.60	190.0	94.0	173.0	241.0	140.0	88.0	121.0
	125	TSB15TE0G	22.70	220.0	94.0	173.0	241.0	143.5	91.0	147.0
150	150	TSB15TE0J	27.90	305.0	94.0	173.0	241.0	152.5	94.0	173.0
200	100	TSB20TE0F	28.50	195.0	100.0	225.0	294.0	170.0	88.0	121.0
	125	TSB20TE0G	30.80	220.0	100.0	225.0	294.0	173.5	91.0	147.0
	150	TSB20TE0J	33.40	250.0	100.0	225.0	294.0	177.5	94.0	173.0
	200	TSB20TE0K	41.90	360.0	100.0	225.0	294.0	180.0	100.0	225.0
250	100	TSB25TE0F	41.30	234.0	105.0	277.0	351.0	183.0	88.0	121.0
	150	TSB25TE0J	45.90	251.0	105.0	277.0	351.0	164.5	94.0	173.0
	200	TSB25TE0K	54.50	344.0	105.0	277.0	351.0	168.0	100.0	225.0
	250	TSB25TE0L	65.20	404.0	105.0	277.0	351.0	202.0	105.0	277.0
300	100	TSB30TE0F	57.80	237.0	110.0	329.0	408.0	213.0	88.0	121.0
	150	TSB30TE0J	68.10	347.0	110.0	329.0	408.0	194.5	94.0	173.0
	200	TSB30TE0K	70.30	347.0	110.0	329.0	408.0	198.0	100.0	225.0
	250	TSB30TE0L	85.40	467.0	110.0	329.0	408.0	207.0	105.0	277.0
300	TSB30TE0M	92.10	467.0	110.0	329.0	408.0	233.5	110.0	329.0	

Standard Nitrile joint included.
Blue references are certified



Bend with STANDARD joint

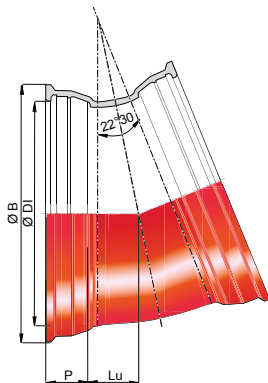
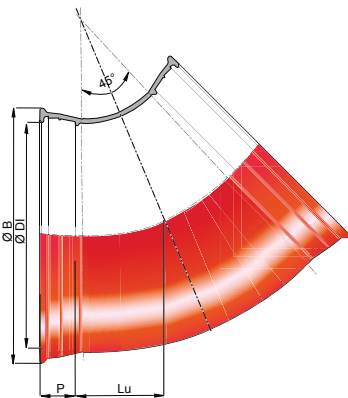
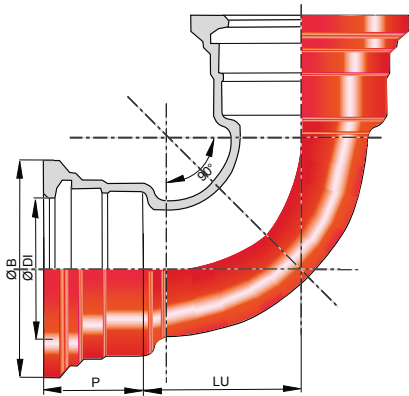

DN mm	reference	mass kg	angle degrees	Lu	P	DI	B
				mm			
80	TSA80CA	7.90	90°	91.5	85.0	101.0	167.5
100	TSB10CA	10.40		105.0	88.0	121.0	187.5
125	TSB12CA	13.90		133.5	91.0	147.0	214.5
150	TSB15CA	18.70		152.5	94.0	173.0	241.0
200	TSB20CA	30.00		200.0	100.0	225.0	294.0
250	TSB25CA	50.60		252.0	105.0	277.0	351.0
300	TSB30CA	74.20		304.0	110.0	329.0	408.0
350	TSB35CA	115.00		390.0	110.0	381.4	464.3
400	TSB40CA	141.00		436.0	112.0	432.4	515.3
450	TSB45CA	144.00		482.0	115.5	483.5	573.0
500	TSB50CA	215.00		525.0	117.5	535.5	628.0
600	TSB60CA	311.00		624.0	132.5	638.6	737.0
700	TSB70CA	443.00		670.0	150.0	742.2	861.0
800	TSB80CA	696.00	735.0	160.0	846.3	972.0	
900	TSB90CA	800.00	880.0	175.0	949.4	1080.0	
1000	TSC10CA	1461.00	1000.0	185.0	1052.5	1189.0	
80	TSA80CB	7.30	45°	56.5	85.0	101.0	167.5
100	TSB10CB	9.30		65.0	88.0	121.0	187.5
125	TSB12CB	12.80		83.5	91.0	147.0	214.5
150	TSB15CB	16.20		92.5	94.0	173.0	241.0
200	TSB20CB	24.50		100.0	100.0	225.0	294.0
250	TSB25CB	41.50		136.0	105.0	277.0	351.0
300	TSB30CB	60.50		167.5	110.0	329.0	408.0
350	TSB35CB	75.20		168.0	110.0	381.4	464.3
400	TSB40CB	88.50		189.0	112.0	432.4	515.3
450	TSB45CB	118.30		216.0	115.5	483.5	573.0
500	TSB50CB	146.00		220.0	117.5	535.5	628.0
600	TSB60CB	208.40		283.0	132.5	638.6	737.0
700	TSB70CB	319.00		335.5	150.0	742.2	861.0
800	TSB80CB	414.10	364.5	160.0	846.3	972.0	
900	TSB90CB	545.10	403.5	175.0	949.4	1080.0	
1000	TSC10CB	703.30	439.5	185.0	1052.5	1189.0	
1100	SSC11CB00FF	980.00	540.0	190.0	1155.0	1300.0	
1200	SSC12CB00FF	1015.00	537.5	195.0	1263.0	1412.5	
1400	SSC14CB00FF	1555.00	522.0	255.0	1467.0	1600.0	
1500	SSC15CB00FF	1815.00	572.0	280.0	1570.0	1742.0	
1600	SSC16CB00FF	2089.00	563.0	275.0	1673.0	1820.0	
1800	SSC18CB00FF	3126.00	642.0	258.0	1881.7	2038.2	
2000	SSC20CB00FF	3702.00	685.0	290.0	2089.0	2269.0	
80	TSA80CD	6.50	22°30'	32.0	85.0	101.0	167.5
100	TSB10CD	8.20		35.0	88.0	121.0	187.5
125	TSB12CD	10.40		38.0	91.0	147.0	214.5
150	TSB15CD	12.80		42.0	94.0	173.0	241.0
200	TSB20CD	19.70		51.0	100.0	225.0	294.0
250	TSB25CD	33.20		70.0	105.0	277.0	351.0
300	TSB30CD	43.70		70.0	110.0	329.0	408.0
350	TSB35CD	53.20		78.0	110.0	381.4	464.3
400	TSB40CD	68.70		92.0	112.0	432.4	515.3
450	TSB45CD	88.15		100.0	115.5	483.5	573.0
500	TSB50CD	108.00		110.0	117.5	535.5	628.0
600	TSB60CD	143.90		140.0	132.5	638.6	737.0
700	TSB70CD	239.00		157.5	150.0	742.2	861.0
800	TSB80CD	303.00	170.5	160.0	846.3	972.0	
900	TSB90CD	405.60	197.5	175.0	949.4	1080.0	
1000	TSC10CD	507.40	217.5	185.0	1052.5	1189.0	
1100	SSC11CD00FF	650.00	275.0	190.0	1155.0	1300.0	
1200	SSC12CD00FF	644.00	258.5	195.0	1263.0	1412.5	
1400	SSC14CD00FF	1107.00	264.0	255.0	1467.0	1600.0	
1500	SSC15CD00FF	1367.00	314.0	280.0	1570.0	1742.0	
1600	SSC16CD00FF	1479.00	284.0	275.0	1673.0	1820.0	
1800	SSC18CD00FF	2070.00	337.0	258.0	1881.7	2038.2	
2000	SSC20CD00FF	2668.00	355.0	290.0	2089.0	2269.0	

Standard Nitrile joint included up to DN 1000. DN 1100 to 2000, joint not included.
Blue references are certified



Bend with STANDARD joint

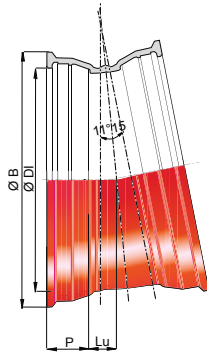

DN mm	reference	mass kg	angle degrees	Lu	P	DI	B
				mm			
80	TSA80CE	6.80	11.15°	40.0	85.0	101.0	167.5
100	TSB10CE	8.30		40.0	88.0	121.0	187.5
125	TSB12CE	10.80		45.0	91.0	147.0	214.5
150	TSB15CE	13.20		46.0	94.0	173.0	241.0
200	TSB20CE	20.00		52.0	100.0	225.0	294.0
250	TSB25CE	31.50		55.0	105.0	277.0	351.0
300	TSB30CE	41.20		50.0	110.0	329.0	408.0
350	TSB35CE	49.00		53.0	110.0	381.4	464.3
400	TSB40CE	61.50		58.0	112.0	432.4	515.3
450	TSB45CE	79.60		67.0	115.5	483.5	573.0
500	TSB50CE	96.20		71.0	117.5	535.5	628.0
600	TSB60CE	128.00		94.0	132.5	638.6	737.0
700	TSB70CE	204.00		87.0	150.0	742.2	861.0
800	TSB80CE	253.40		90.5	160.0	846.3	972.0
900	TSB90CE	325.60		102.5	175.0	949.4	1080.0
1000	TSC10CE	414.40		117.5	185.0	1052.5	1189.0
1100	SSC11CE00FF	490.00		140.0	190.0	1155.0	1300.0
1200	SSC12CE00FF	478.00		137.5	195.0	1263.0	1412.5
1400	SSC14CE00FF	884.00		143.0	255.0	1467.0	1600.0
1500	SSC15CE00FF	1143.00		193.0	280.0	1570.0	1742.0
1600	SSC15CE00FF	1173.00	153.0	275.0	1673.0	1820.0	
1800	SSC18CE00FF	1542.00	200.0	258.0	1881.7	2038.2	
2000	SSC20CE00FF	2151.00	200.0	290.0	2089.0	2269.0	

STANDARD Nitrile joint included up to DN 1000. DN 1100 to 2000, joint not included. Blue references are certified NF.

Flanged socket with STANDARD joint

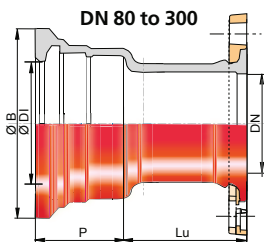

DN 350 to 600

DN 700 to 2000

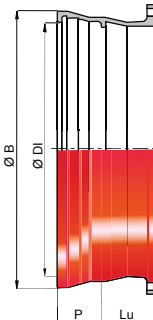
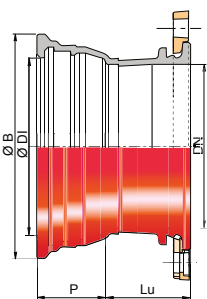

DN mm	reference		mass (kg)		Lu	P	DI	ØB
	PN10	PN16	PN10	PN16				
80	TSA80BE1		7.40	7.40	110.0	85.0	101.0	167.5
100	TSB10BE1		8.90	8.90	110.0	88.0	121.0	187.5
125	TSB12BE1		11.30	11.30	110.0	91.0	147.0	214.5
150	TSB15BE1		14.10	14.10	115.0	94.0	173.0	241.0
200	TSB20BE1	TSB20BE2	20.80	20.70	120.0	100.0	225.0	294.0
250	TSB25BE1	TSB25BE2	31.80	30.90	125.0	105.0	277.0	351.0
300	TSB30BE1	TSB30BE2	42.80	42.10	130.0	110.0	329.0	408.0
350	TSB35BE1	TSB35BE2	59.00	59.80	135.0	110.0	381.4	464.3
400	TSB40BE1	TSB40BE2	65.00	69.10	140.0	112.0	432.4	515.3
450	TSB45BE1	TSB45BE2	82.00	88.40	145.0	115.5	483.5	573.0
500	TSB50BE1	TSB50BE2	85.00	98.20	170.0	117.5	535.5	628.0
600	TSB60BE1	TSB60BE2	124.00	149.00	170.0	132.5	638.6	737.0
700	TSB70BE1	TSB70BE2	158.00	166.00	190.0	150.0	742.2	861.0
800	TSB80BE1	TSB80BE2	211.00	220.00	200.0	160.0	846.3	972.0
900	TSB90BE1	TSB90BE2	258.00	-	210.0	175.0	949.4	1080.0
1000	TSC10BE1	TSC10BE2	342.00	-	220.0	185.0	1052.5	1189.0
1100	SSC11BE10FF	SSC11BE20FF	350.00	-	220.0	150.0	1155.0	1298.0
1200	SSC12BE10FF	SSC12BE20FF	440.00	484.00	240.0	195.0	1263.0	1412.0
1400	SSC14BE10FF	SSC14BE20FF	716.00	768.00	310.0	255.0	1467.0	1600.0
1500	SSC15BE10FF	SSC15BE20FF	898.00	986.00	360.0	280.0	1570.0	1742.0
1600	SSC16BE10FF	SSC16BE10FF	963.00	-	330.0	275.0	1673.0	1820.0
1800	SSC18BE10FF	SSC18BE20FF	-	-	387.0	258.0	1881.7	2038.0
2000	SSC20BE10FF	SSC20BE20FF	1659.00	1789.00	395.0	290.0	2089.0	2269.0

STANDARD Nitrile joint included up to DN 1000. DN 1100 to 2000, joint not included. Blue references are certified NF.



Flanged spigot PN10

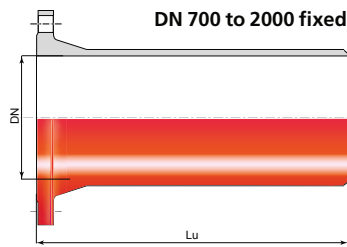
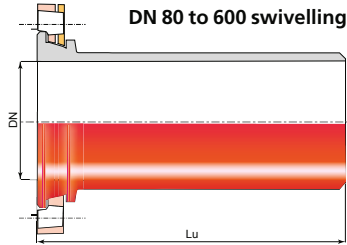

DN mm	reference PN10	mass kg	Lu mm
80	TEA80BU1	7.80	350.0
100	TEB10BU1	9.70	350.0
125	TEB12BU1	12.50	350.0
150	TEB15BU1	15.80	400.0
200	TEB20BU1	23.00	400.0
250	TEB25BU1	32.00	400.0
300	TEB30BU1	43.00	450.0
350	TEB35BU1	52.50	450.0
400	TEB40BU1	64.50	480.0
450	TEB45BU1	86.00	500.0
500	TEB50BU1	95.00	520.0
600	TEB60BU1	133.00	600.0
700	TEB70BU1	189.00	600.0
800	TEB80BU1	234.00	600.0
900	TEB90BU1	287.00	600.0
1000	TEC10BU1	354.00	600.0
1100	SEC11BU10FF	400.00	600.0
1200	SEC12BU10FF	469.00	600.0
1400	SSC14BU10FF	674.00	710.0
1500	SSC15BU10FF	802.00	750.0
1600	SSC16BU10FF	935.00	780.0
1800	SSC18BU10FF	1256.00	845.0
2000	SSC20BU10FF	1643.00	885.0

For higher PN's, please consult us.
Blue references are certified NF.

Blank flange PN10

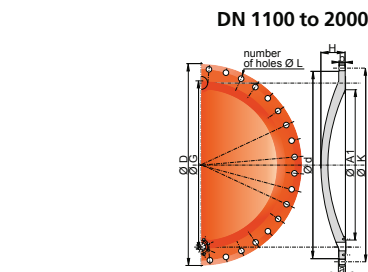
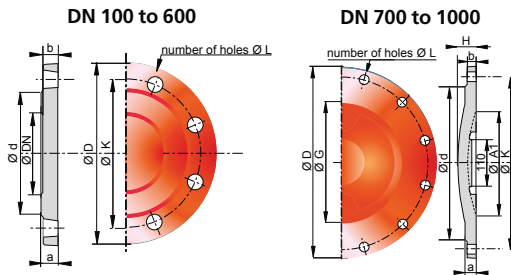

DN mm	reference	mass kg	Ø D	a	b	Ø d	Ø G	H	number holes	Ø L	Ø K	A1
100	TBB10QN10FF	4.30	220.0	19.0	16.0	153.0	-	-	8	19.0	180.0	-
125	TBB12QN10FF	5.60	250.0	19.0	16.0	183.0	-	-	8	19.0	210.0	-
150	TBB15QN10FF	7.20	285.0	19.0	16.0	209.0	-	-	8	23.0	240.0	-
200	TBB20QN10FF	11.00	340.0	20.0	17.0	264.0	-	-	8	23.0	295.0	-
250	TBB25QN10FF	16.90	400.0	22.0	19.0	319.0	-	-	12	23.0	350.0	-
300	TBB30QN10FF	26.50	455.0	24.5	20.5	367.0	290.0	40.5	12	23.0	400.0	246.0
350	TBB35QN10FF	32.50	505.0	24.5	20.5	427.0	340.0	50.3	16	23.0	505.0	290.0
400	TBB40QN10FF	41.00	565.0	24.5	20.5	480.0	385.0	62.0	16	28.0	515.0	350.0
450	TBB45QN10FF	55.00	615.0	25.5	21.5	530.0	435.0	68.5	20	28.0	565.0	430.0
500	TBB50QN10FF	70.00	670.0	26.5	22.5	585.0	490.0	58.0	20	28.0	620.0	450.0
600	TBB60QN10FF	106.00	780.0	33.0	28.0	682.0	585.0	88.0	20	31.0	725.0	550.0
700	TBB70QN10FF	153.00	895.0	32.5	27.5	794.0	680.0	101.0	24	31.0	840.0	650.0
800	TBB80QN10FF	214.00	1015.0	35.0	30.0	901.0	785.0	114.0	24	34.0	950.0	750.0
900	TBB90QN10FF	279.00	1115.0	37.5	32.5	1001.0	885.0	127.0	28	34.0	1050.0	850.0
1000	TBC10QN10FF	367.00	1230.0	40.0	35.0	1112.0	985.0	140.0	28	37.0	1160.0	950.0
1100	TBC11QN10FF	405.00	1340.0	42.5	37.5	1218.0	1085.0	147.5	32	37.0	1270.0	1050.0
1200	BBC12QN10FF	506.00	1455.0	45.0	40.0	1328.0	1185.0	160.0	32	41.0	1380.0	1150.0
1400	BBC14QN10FF	847.00	1675.0	46.0	41.0	1530.0	1375.0	192.0	36	43.0	1590.0	-
1500	Please consult us	1027.00	1785.0	47.5	42.5	1640.0	1475.0	205.0	36	43.0	1700.0	-
1600	BBC16QN10FF	1239.00	1915.0	49.0	44.0	1750.0	1575.0	218.0	40	49.0	1820.0	-
1800	BBC18QN10FF	1717.00	2115.0	52.0	47.0	1950.0	1775.0	244.0	44	49.0	2020.0	-
2000	BBC20QN20FF	2272.00	2325.0	55.0	50.0	2150.0	1975.0	270.0	48	49.0	2230.0	-

For higher PN's, please consult us.
Blue references are certified NF.



Tee with two sockets and flanged branch

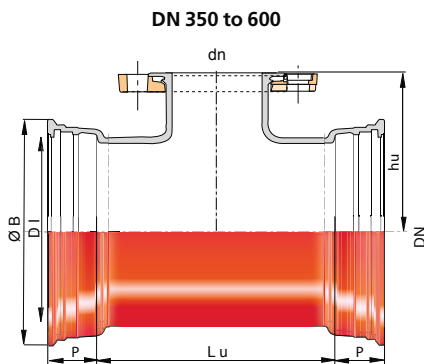
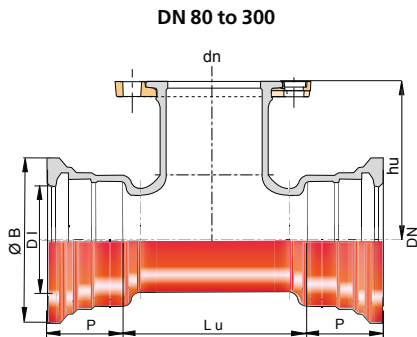

DN mm	dn mm	reference		mass kg		Lu	hu	P	DI	B
		PN10	PN16	PN10	PN16					
80	80	TSA80UD1E		12.80		183.0	165.0	85.0	101.0	167.5
	100	TSB10UD1E		15.00		185.0	177.0	88.0	121.0	187.5
100	100	TSB10UD1F		16.80		210.0	180.0	88.0	121.0	187.5
	80	TSB12UD1E		17.30		165.0	195.0	91.0	147.0	214.5
125	100	TSB12UD1F		19.00		190.0	200.0	91.0	147.0	214.5
	125	TSB12UD1G		23.50		267.0	200.0	91.0	147.0	214.5
150	80	TSB15UD1E		20.20		165.0	210.0	94.0	173.0	241.0
	100	TSB15UD1F		22.00		190.0	215.0	94.0	173.0	241.0
	125	TSB15UD1G		24.40		220.0	210.0	94.0	173.0	241.0
	150	TSB15UD1J		30.10		305.0	220.0	94.0	173.0	241.0
200	80	TSB20UD1E		27.80		170.0	240.0	100.0	225.0	294.0
	100	TSB20UD1F		29.90		195.0	245.0	100.0	225.0	294.0
	125	TSB20UD1G		32.40		220.0	240.0	100.0	225.0	294.0
	150	TSB20UD1J		35.70		250.0	245.0	100.0	225.0	294.0
	200	TSB20UD1K	TSB20UD2K	45.50	45.40	360.0	260.0	100.0	225.0	294.0
250	80	TSB25UD1E		44.60		234.0	250.0	105.0	277.0	351.0
	100	TSB25UD1F		44.50		234.0	270.0	105.0	277.0	351.0
	150	TSB25UD1J		50.50		251.0	280.0	105.0	277.0	351.0
	200	TSB25UD1K	TSB25UD2K	61.30	61.20	344.0	290.0	105.0	277.0	351.0
	250	TSB25UD1L	TSB25UD2L	70.60	70.20	404.0	300.0	105.0	277.0	351.0
300	80	TSB30UD1E		58.90		237.0	298.0	110.0	329.0	408.0
	100	TSB30UD1F		59.60		237.0	300.0	110.0	329.0	408.0
	150	TSB30UD1J		72.70		347.0	310.0	110.0	329.0	408.0
	200	TSB30UD1K	TSB30UD2K	77.20	77.20	347.0	320.0	110.0	329.0	408.0
	300	TSB30UD1M	TSB30UD2M	99.40	98.70	467.0	340.0	110.0	329.0	408.0
350	80	TSB35UD1E		73.70		194.0	310.0	110.0	381.4	464.3
	100	TSB35UD1F		90.70		195.0	330.0	110.0	381.4	464.3
	150	TSB35UD1J		88.70		314.0	340.0	110.0	381.4	464.3
	200	TSB35UD1K	TSB35UD2K	92.70	92.60	314.0	350.0	110.0	381.4	464.3
	350	TSB35UD1Y	TSB35UD2Y	132.80	132.00	485.0	380.0	110.0	381.4	464.3
400	80	TSB40UD1E		86.40		195.0	340.0	112.0	432.4	515.3
	100	TSB40UD1F		85.80		195.0	350.0	112.0	432.4	515.3
	150	TSB40UD1J		102.50		315.0	370.0	112.0	432.4	515.3
	200	TSB40UD1K	TSB40UD2K	107.30	107.20	315.0	380.0	112.0	432.4	515.3
	400	TSB40UD1N	TSB40UD2N	164.30	168.40	545.0	420.0	112.0	432.4	515.3
500	100	TSB50UD1F		121.50		210.0	420.0	117.5	535.5	628.0
	150	TSB50UD1J		136.60		325.0	430.0	117.5	535.5	628.0
	200	TSB50UD1K	TSB50UD2K	150.40	150.30	325.0	440.0	117.5	535.5	628.0
	400	TSB50UD1N	TSB50UD2N	217.00	221.10	555.0	480.0	117.5	535.5	628.0
	500	TSB50UD1Q	TSB50UD2Q	267.40	280.60	675.0	500.0	117.5	535.5	628.0
600	100	TSB60UD1F		190.10		335.0	500.0	132.5	638.6	737.0
	200	TSB60UD1K	TSB60UD2K	196.60	196.50	335.0	500.0	132.5	638.6	737.0
	400	TSB60UD1N	TSB60UD2N	275.00	279.10	570.0	540.0	132.5	638.6	737.0
	600	TSB60UD1R	TSB60UD2R	377.60	402.60	800.0	580.0	132.5	638.6	737.0

Standard Nitrile joint included.
Blue references are certified



Tee with two sockets and flanged branch

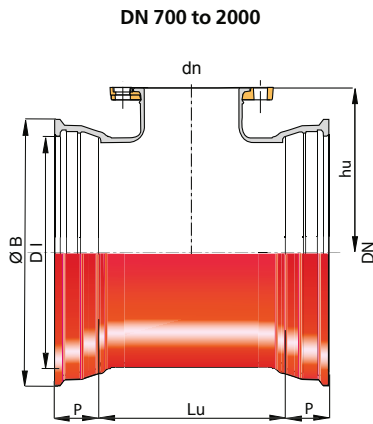

DN mm	dn mm	reference		mass kg		Lu	hu	P	DI	B
		PN10	PN16	PN10	PN16					
700	150	TSB70UD1J		172.00		365.0	520.0	150.0	742.2	861.0
	200	TSB70UD1K	TSB70UD2K	196.60	265.00	365.0	525.0	150.0	742.2	861.0
	400	TSB70UD1N	TSB70UD2N	275.00	351.00	585.0	555.0	150.0	742.2	861.0
	700	TSB70TD1S	TSB70TD2S	498.00	546.00	915.0	600.0	150.0	742.2	861.0
800	150	TSB80UD1J		332.00		355.0	580.0	160.0	846.3	972.0
	200	TSB80UD1K	TSB80UD2K	335.00	335.00	355.0	585.0	160.0	846.3	972.0
	400	TSB80UD1N	TSB80UD2N	430.00	435.00	575.0	615.0	160.0	846.3	972.0
	800	TSB80TD1T	TSB80TD2T	663.00	674.00	1015.0	675.0	160.0	846.3	972.0
900	200	TSB90UD1K	Please consult us	420.00	-	375.0	645.0	175.0	949.4	1080.0
	400	TSB90UD1N	Please consult us	532.00	-	595.0	675.0	175.0	949.4	1080.0
	900	TSB90TD1U	Please consult us	867.00	-	1145.0	750.0	175.0	949.4	1080.0
1000	150	TSC10UD1J		447.00		379.0	705.0	185.0	1052.5	1189.0
	200	TSC10UD1K	Please consult us	510.00	-	379.0	705.0	185.0	1052.5	1189.0
	400	TSC10UD1N	Please consult us	639.00	-	598.5	735.0	185.0	1052.5	1189.0
	1000	TSC10TD1V	Please consult us	1115.00	-	1258.0	830.0	185.0	1052.5	1189.0
1100	200	Please consult us	Please consult us	-	-	822.5	880.0	150.0	1155.0	1298.0
	300	Please consult us	Please consult us	-	-	822.5	838.0	150.0	1155.0	1298.0
	400	Please consult us	Please consult us	-	-	822.5	835.0	150.0	1155.0	1298.0
	600	SSC11UD1RFF	Please consult us	907.00	-	822.5	885.0	150.0	1155.0	1298.0
1200	200	SSC12UD1KFF	SSC12UD2KFF	949.00	949.00	855.0	880.0	195.0	1263.0	1412.0
	300	Please consult us	SSC12UD2MFF	-	927.00	855.0	838.0	195.0	1263.0	1412.0
	400	SSC12UD1NFF	SSC12UD2NFF	938.00	943.00	855.0	835.0	195.0	1263.0	1412.0
	600	SSC12UD1RFF	SSC12UD2RFF	952.00	977.00	855.0	885.0	195.0	1263.0	1412.0
1400	600	SSC14UD1RFF	SSC14UD2RFF	1542.00	1567.00	1010.0	980.0	255.0	1467.0	1600.0
1500	600	SSC15UD1RFF	Please consult us	1790.00	-	1110.0	980.0	280.0	1570.0	1742.0
1600	300	SSC16UD1MFF	SSC16UD2MFF	1977.00	1967.00	1050.0	1050.0	275.0	1673.0	1820.0
	500	Please consult us	Please consult us	-	-	1050.0	1075.0	275.0	1673.0	1820.0
	600	SSC16UD1RFF	Please consult us	1997.00	-	1050.0	1090.0	275.0	1673.0	1820.0
1800	200	Please consult us	Please consult us	-	-	1125.0	1140.0	258.0	1881.7	2038.0
	300	Please consult us	Please consult us	-	-	1125.0	1155.0	258.0	1881.7	2038.0
2000	300	Please consult us	Please consult us	-	-	1110.0	1265.0	290.0	2089.0	2269.0
	500	Please consult us	Please consult us	-	-	1110.0	1295.0	290.0	2089.0	2269.0

Standard Nitrile joint included up to DN 1000.
 DN 1100 to 2000, joint not included.
 If DN ≥ 700: fixed flange.
 Blue references are certified



INTEGRAL® RANGE: valves - shut-off valves

Penstock with square hole



Penstock accessories



L mm	non-rising stem		rising stem	
	reference	mass kg	reference	mass kg
150	229936	17.00	229964	12.00
200	229937	20.00	229965	15.00
250	229939	25.00	229999	18.00
300	229940	27.00	230000	21.00
400	229942	40.00	230001	32.00
500	229943	53.00	230002	44.00
600	229944	66.00	230003	55.00
700	229945	96.00	230004	71.00
800	229946	111.00	229986	86.00
900	229947	128.00	230006	99.00
1000	229948	147.00	230007	116.00

For diameters larger than 1000, please consult us.

type	HAND STOCK (non-rising stem)		EXTENSIONS				
	reference	mass kg	type	length mm	mass kg	reference	
Handwheel	< 700	229936	18	Telescopic	800-1200	5	230018
	> 600	229937	20		Fix	1500	6
Red + Handwheel		229939	39			3000	12
Red + manivelle with motor		229942	30	ACCESSORIES			
Handwheel wall bracket	< 700	229943	18	type	length mm	mass kg	reference
	> 600	229944	18				
Gearbox with wall bracket & handwheel		229945	46	Hand-wheel	< 700	3	230041
Gearbox with wall bracket & handlever		229946	46		> 600	7	230080
Motorized with motor		229947	30	Support		1	230081
				Engine support		1	230082
				Cap top		1	230761

Knife gate valve



DN 50-400

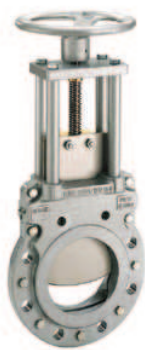

DN 450-1200

DN mm	AOP bar	reference	mass kg
50	10	161828	7.00
65	10	161829	8.00
80	10	161830	9.00
100	10	161827	12.00
125	10	161831	14.00
150	10	161839	22.00
200	10	161840	27.00
250	6	161841	40.00
300	6	161842	60.00
350	4	161843	89.00
400	4	161834	115.00

DN mm	AOP bar	reference	mass kg
450	4	173312	210.00
500	4	161836	230.00
600	4	161837	369.00
700	4	161838	680.00
800	4	173311	840.00
900	4	182498	1220.00
1000	4	167224	1680.00
1200	4	167225	2990.00

For knife gate valves actuator version DN > 1200, consult us.
Gate stainless and steel - Drilling ISO PN 10

Body ductile iron with epoxy coating.

EURO 20 sewerage shut-off valve type 23



DN mm	reference	mass kg
40	REA40PBCH	9.50
50	REA50PBCH	10.50
65	RDA65PNCH	15.00
80	RDA80PNCH	15.60
100	RDB10PNCH	19.70
125	RDB12PNCH	26.60
150	RDB15PNCH	33.30
200	RDB20PBBH	66.00
250	RDB25PBBH	108.00
300	REB30PBBH	155.00

DN mm	reference	mass kg
65	RDA65PHCH	40.00
80	RDA80PHCH	41.00
100	RDB10PHCH	48.00
125	RDB12PHCH	55.00
150	RDB15PHCH	63.00
200	REB20PHBH	130.00
250	REB25PHBH	165.00
300	REB30PHBH	199.00

For strained waters - AOP 10 bar. Joint and opercule elastomer coating made from Nitrile.
Installation in a chamber or above ground.

Sewerage air valve AOP 10 bar



DN mm	single function small flow 5 m³/h		single function large flow 430 m³/h		triple function large + small flow + air valve 430 and 5 m³/h	
	reference	mass kg	reference	mass kg	reference	mass kg
80	RCA80EPBF	28	RCA80EQBF	28.00	161771	65.00
100	-	-	RCB10EQBF	35.00	RCB10ERBF	35.00
150	-	-	RCB15EQBF	48.00	RCB15ERBF	48.00

Upon request: flanged air valve DN 100 and 150 with higher flow rate.



INTEGRAL® RANGE: valves - protection - joints

Ball check valve AOP 10 bar



DN mm	reference	mass kg
50	RCA50FMCF	8.00
65	RCA65FMCF	14.00
80	RCA80FMCF	16.00
100	RCB10FMCF	21.00
125	RCB12FMCF	38.00
150	RCB15FMCF	52.00
200	RCB20FMBF	99.00
250	RCB25FMBF	160.00
300	RCB30FMBF	240.00

Round or square end valve to be sealed without counterweight

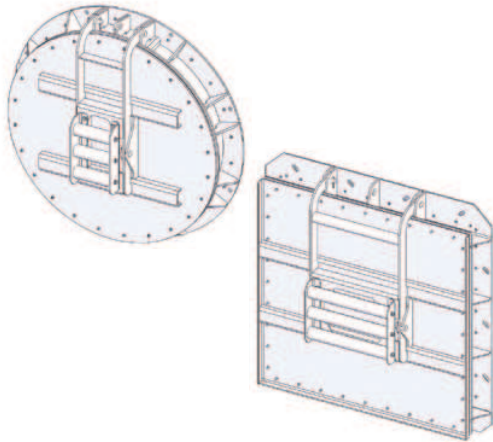

DN mm	circular		square	
	reference	mass kg	reference	mass kg
80	232179	8.00	232768	25.00
100	232181	9.00	232769	30.00
150	232182	16.00	232770	40.00
200	232183	21.00	232772	45.00
250	232184	27.00	232773	50.00
300	232187	33.00	232775	55.00
350	232188	40.00	232777	60.00
400	232190	48.00	232778	65.00
450	232192	62.00	232779	70.00
500	232193	74.00	232780	85.00
600	232195	84.00	232781	105.00
700	232198	106.00	232782	120.00
800	232200	136.00	232783	135.00
900	232203	155.00	232784	165.00
1000	232238	185.00	232785	195.00

For DN's greater than 1000, please consult us.

ViLoK® STANDARD Vi® joint gasket (NBR)



ANGULAR DEFLECTIONS

DN	Pipes	Fittings
80 to 150	5°	5°
200 to 250	4°	4°
300 to 350	3°	2°
400 to 700	2°	1,8°

DN mm	reference
80	JSA80CW
100	JSB10CW
125	JSB12CW
150	JSB15CW
200	JSB20CW
250	JSB25CW
300	JSB30CW
350	JSB35CW
400	JSB40CW
450	JSB45CW
500	JSB50CW
600	JSB60CW
700	JSB70CW

Flanged joint gasket



DN mm	reference
50	JBA50GW1
80	JBA80GW1
100	JBB10GW1
125	JBB12GW1
150	JBB15GW1
200	JBB20GW1
250	JBB25GW1
300	JBB30GW1
350	JBB35GV1
400	JBB40GV1
450	JBB45GV1
500	JBB50GV1
600	JBB60GV1
700	JBB70GV1
800	JBB80GV1
900	JBB90GV1
1000	JBC10GV1
1100	JBC11GV1
1200	JBC12GV1
1400	JBC14GV1
1500	JBC15GV1
1600	JBC16GV1
1800	JBC18GV1
2000	JBC20GV1

STANDARD Ve® anchored joints

The reference contains all anchoring accessories including the NBR elastomer joint gasket.

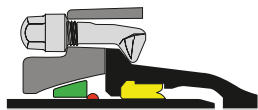

DN mm	reference
150	JSB15V-E01
200	JSB20V-E01
250	JSB25V-E01
300	JSB30V-E01
350	JSB35V-E02
400	JSB40V-E02
450	JSB45V-E02
500	JSB50V-E02
600	JSB60V-E02
700	JSB70V-E01
800	JCB80V-E01
900	JCB90V-E01
1000	JCC10V-E01
1100	JSC11V-E01
1200	JSC12V-E01

For higher DN's, please consult us.