

## Bend 45° (1/8) (PECB) with 2 sockets EXPRESS

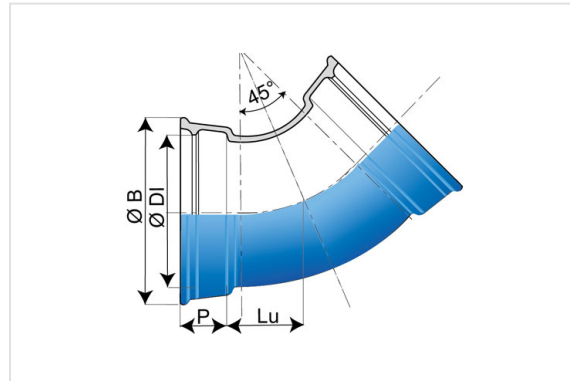

Angle	DN (mm)	Lu (mm)	P (mm)	ØDI (mm)	ØB (mm)	Mass (kg)	References
45°	100	60	80	121.4	187.5	6.41	293377
45°	125	65	83	147.4	214.5	7.00	293378
45°	150	75	86	173.4	241.5	10.00	290767
45°	200	95	92	225.5	294.5	14.80	291956
45°	350	156.2	110	381.9	462	58.60	SEB35CB00TT2
45°	400	175	110	432.9	514	77.28	SEB40CB00TT2
45°	450	198.7	120	484	575.4	92.09	SEB45CB00TT2
45°	500	217.5	120	536	627	125.16	SEB50CB00TT2
45°	600	260	135	639.1	736.3	185.12	SEB60CB00TT2
45°	700	335.5	150	742	861	312.00	SEB70CB00TT
45°	800	364.5	160	846	972	417.00	SEB80CB00TT
45°	900	403.5	175	949	1080	551.00	SEB90CB00TT
45°	1000	439.5	145	1052	1189	649.00	SEC10CB00TT

### Field of use:

- For drinking water and irrigation networks
- For aggressive soils (maritime soils, peaty, ...)

## Main characteristics:

- External and internal coating : Blue epoxy powder 250 microns average thickness with a minimum of 200 microns, conforming to EN 14901-1 (PECB)
- In conformity with EN 545:2010 and ISO 2531:2009

## Linked products

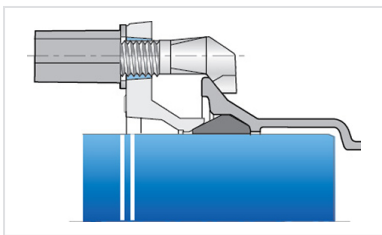

Kit Express Fittings PECB +  
Express Gasket



Kit Express Fitting PECB +  
Express Vi Gasket

*The information on this sketch is, to the best of our knowledge correct at the time of printing. However Saint-Gobain are constantly looking at ways of improving their products and services therefore reserve the right to change without prior notice, any of the data shown. Any orders placed will be subject to our Standard Conditions of Sale, available on request.*