

**QUICK PVC/PE travada**

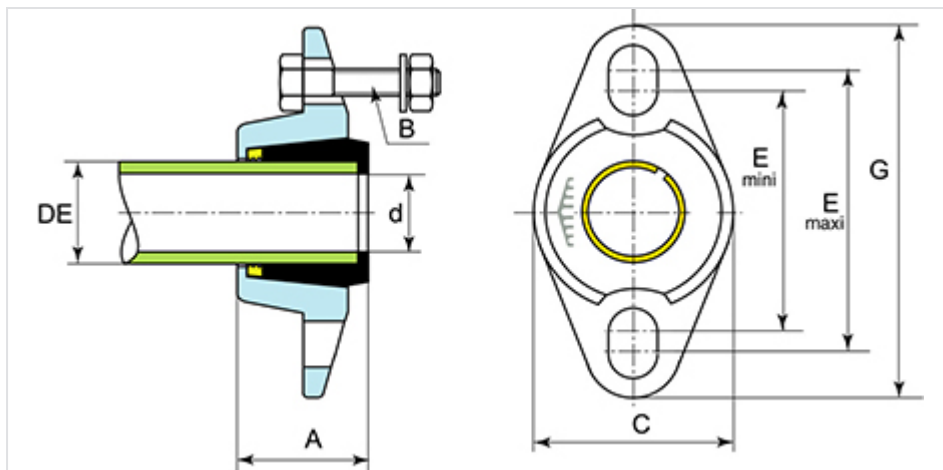

DN Flange (mm)	DN/OD (mm)	ØDE (mm)	E mini (mm)	E maxi (mm)	G (mm)	d (mm)	A (mm)	Parafusos	K (mm)	Peso (kg)	Referência
15/20	25	25	65	75	104	19	37	HM12/50	55	0,40	MAL25DACH
20/25	32	32	75	85	114	25	41	HM12/50	62	0,50	MAL32DACH



## Material e revestimentos

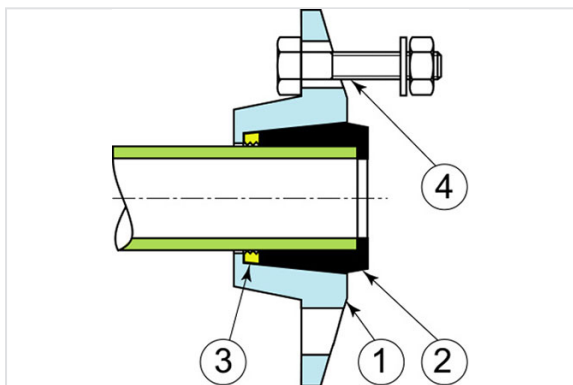

Item	Designação	Material	Revestimento
1	Flange	Ferro dúctil	Tinta epóxi
2	Junta de estanquidade	EPDM	
3	Junta de travamento	Latão	
4	Parafuso com anilha	Aço	Galvanizado