

Flanged 90° Bend with rotatable flanges (PECB) “PROCESS” for restrained and not restrained pipes DN100-400 PN25

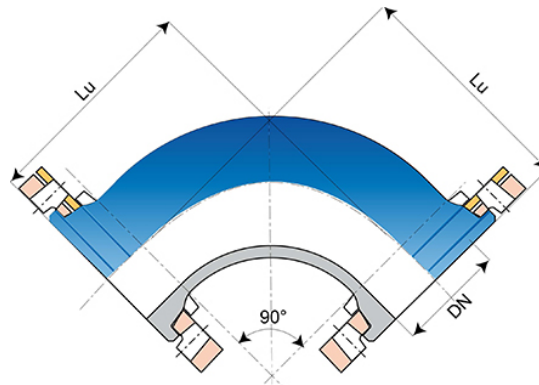

Ductile iron networks for fire protection

Angle	DN (mm)	Lu (mm)	PN	Mass (kg)	References
90°	100	180	25	14.00	BAB10CA30TTF
90°	150	220	25	25.00	BAB15CA30TTF
90°	200	260	25	40.50	BAB20CA30TTF
90°	400	500	25	190.00	BAB40CA30TTF

(*) Consult us

Field of use:

- Any fire protection networks, restrained or not, buried
- Installation in any industrial sites or other works of civil engineering

Main characteristics:

- Pressure strength: tests according to FM Approval CN1610 (see label below)
- Internal and external coating: blue Epoxy Powder 250µm (PECB)
- FM Approval (Factory Mutual System)

Marking :

- The indicated values indicate the pressure tests with or without restraining.
- The certification tests FM are realized according to the FM approvals Class number 1610 (September 2006) referential.
- Marking on high durability engraved laser acrylate label.



DN100-300



DN400

The information on this sketch is, to the best of our knowledge correct at the time of printing. However Saint-Gobain are constantly looking at ways of improving their products and services therefore reserve the right to change without prior notice, any of the data shown. Any orders placed will be subject to our Standard Conditions of Sale, available on request.