

Flange Socket PROCESS FM with socket STANDARD and Rotatable Flange PN25

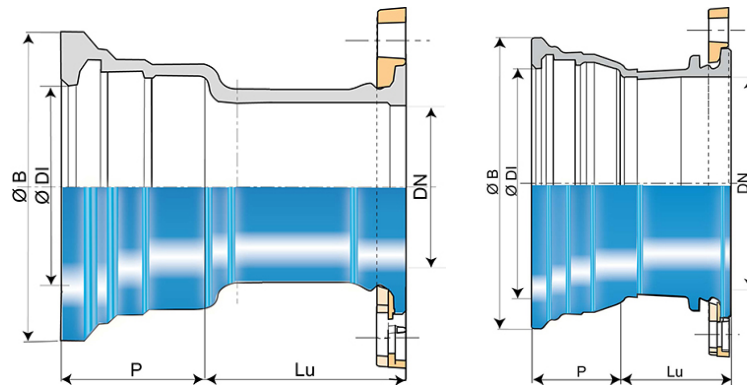

Ductile iron networks for fire protection

DN (mm)	Lu (mm)	P (mm)	ØDI (mm)	ØB (mm)	Mass (kg)	References
100	110	88	121.4	187.5	10.00	SSB10BE30TTF
150	115	94	173.4	241	14.80	SSB15BE30TTF
200	120	100	225.5	294	23.50	SSB20BE30TTF
250	135	105	277.3	351	33.90	SSB25BE30TTF
300	130	110	329.3	408.3	44.90	SSB30BE30TTF
400	140	112	432.4	515.3	78.00	SSB40BE30TTF

Field of use:

- Any fire protection networks, restrained or not, buried
- Installation in any industrial sites or other works of civil engineering

Main characteristics:

- Pressure strength: tests according to FM Approval CN1610 (see label below)
- Internal and external coating: blue Epoxy Powder 250µm (PECB)
- FM Approval (Factory Mutual System)

Marking

- The indicated values indicate the pressure tests with or without restraining.
- The certification tests FM are realized according to the FM approvals Class number 1610 (September 2006) referential.
- Marking on high durability engraved laser acrylate label.



DN100



DN150

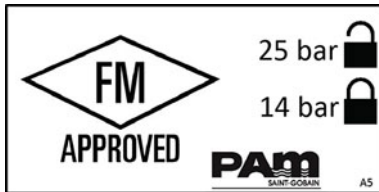

DN200-300



DN400

The information on this sketch is, to the best of our knowledge correct at the time of printing. However Saint-Gobain are constantly looking at ways of improving their products and services therefore reserve the right to change without prior notice, any of the data shown. Any orders placed will be subject to our Standard Conditions of Sale, available on request.