



Manhole cover PARXESS AR C250 class



Hinged rectangular manhole cover manufactured according to EN124 standard, C250 class, composed with cover and frame made of ductile iron according to ISO 1083 with bituminous coating. Clear opening of 510 x 430 mm. Opens to 110° by double hinged system. Handling box on the front of the cover for ergonomic operation with usual tools.

AxB (mm)	O1xO2 (mm)	C1xC2 (mm)	E (mm)	F (mm)	H (mm)	Total Mass (kg)	Cover mass (kg)	Packaging	References
592x670	508x430	570x493	70	44	80	26.00	26	20	CCPK50UZ

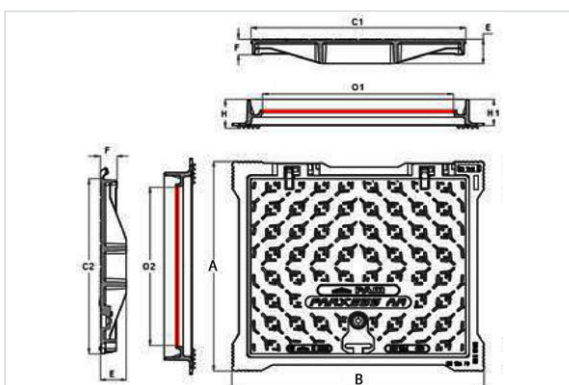



Material and coating:

- Frame and cover in ductile iron EN GJS 400-15 according to the standard ISO 1083 with bituminous coating.

Field of application:

- C250 class (Group 3) according to standard EN 124-2, intended for the circulated pavements and similar locations subjected to the passage of vehicles.
- Periodic inspections.

Main characteristics:

- Compliance with EN124-2:2015 testified by SG PAM as the standard allows it
- Frame with notched flange enabling an effective bedding.
- Non-rock system ensuring the stability of the cover in its frame.
- Hinged cover opens to 110°.
- Handling box.
- Compatibility with standardized concrete boxes.
- Optional locking system.
- Optional cover anti-theft spline.
- Possibility of epoxy coating (on request).
- Personalized cover possibility (on request).

Conformity:

Saint-Gobain PAM attests that:

- the above mentioned products are manufactured in compliance with specifications, materials & characteristics as per EN124-2 : 2015 standard
- the features and performances of the above mentioned products are controlled and comply with requirements of EN124-1 : 2015 standard

The PAM brand affixed on these related products materialises this attestation of conformity.



Linked products

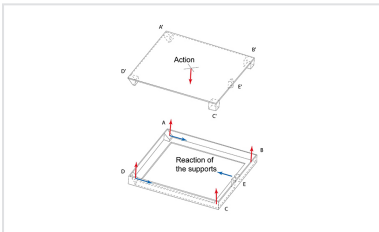

Hydraulic manhole covers
AKSESS - Stability of the covers

The information on this sketch is, to the best of our knowledge correct at the time of printing. However Saint-Gobain are constantly looking at ways of improving their products and services therefore reserve the right to change without prior notice, any of the data shown. Any orders placed will be subject to our Standard Conditions of Sale, available on request.