

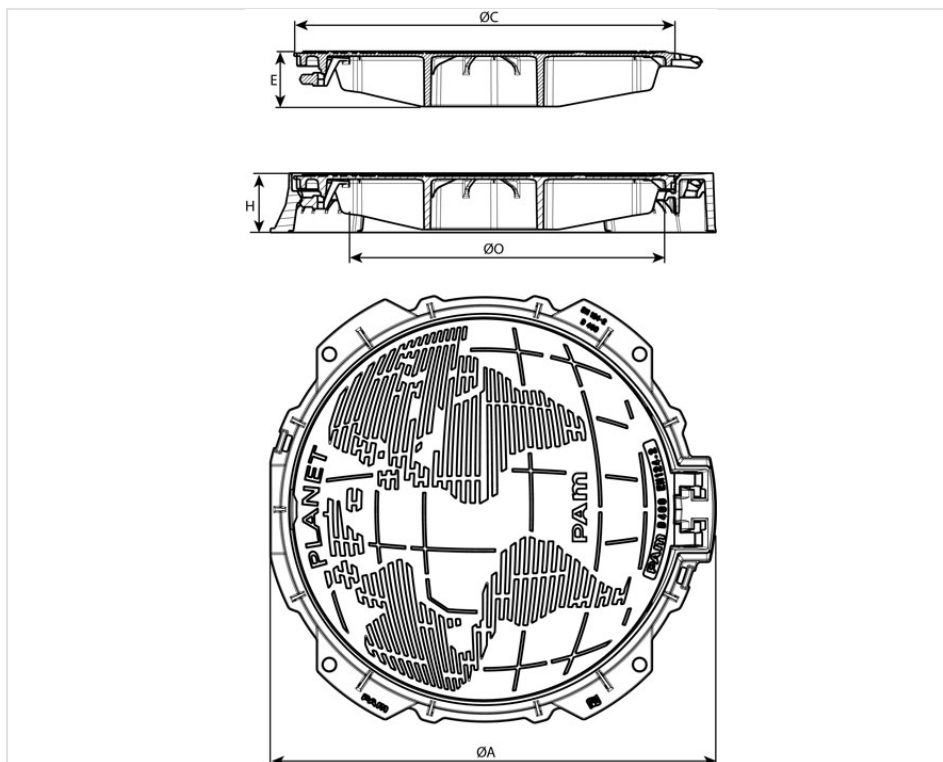

Manhole Cover PLANET Class D400 Round frame Ø 785 – Non Ventilated



A (mm)	C (mm)	O (mm)	H (mm)	E (mm)	Frame bearing pressure	Total Mass (kg)	Cover mass (kg)	Packaging	References
785	643	608	100	93	6.78 N/mm ²	46.20	26.5	10	CDPL60AA





Material and coating:

- Frame and cover in Ductile Iron EN GJS 400-15: water base coating
- [Ring in PE](#)

Field of application:

- Group 4 (class D 400) in accordance with EN124-2 standard: areas bearing low traffic conditions, predominantly defined as private cars passing at restricted speed, typical conditions met in housing areas
- Periodic inspection and visit of sewer mains

Main characteristics:

Cover

- [Automatic locking by ductile iron spring bar](#)
- Unlocking by means of crow bar or pick axe, manual lifting
- Ventilated or not
- Hinged cover, opens to 110°, blocks at 90° when closing
- [Optional cover anti-theft spline, compatible with 90° blocking](#)
- Badging: exclusively generic markings such as e.g. "sewers", "water", "rain water", etc...

Frame bedding

- Reduced frame width logically increases its bearing pressure on chamber top, when submitted to load.
- It is key to ensure that the frame is completely seated on the chamber top, without any cantilever. If necessary, a spare concrete ring can be used between chamber top and frame to improve its seating.
- Frame bedding must be achieved with Class CPA 500 concrete, or with quick setting mortars featuring a minimum resistance to compression of 50 MPa.

Linked products



Polyethylene ring

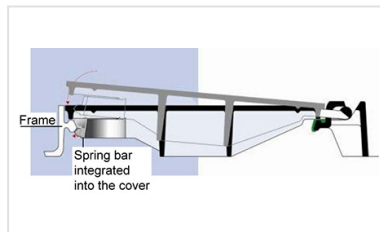

Manhole covers - Locking of the cover by spring bar

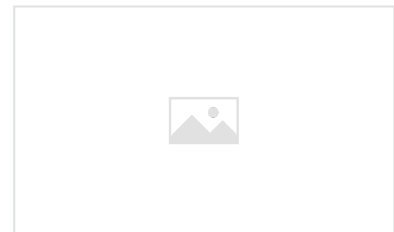

Cover anti theft spline - PLANET / REXESS2



The information on this sketch is, to the best of our knowledge correct at the time of printing. However Saint-Gobain are constantly looking at ways of improving their products and services therefore reserve the right to change without prior notice, any of the data shown. Any orders placed will be subject to our Standard Conditions of Sale, available on request.