

Stability principle: DEDRA 600 grating D400 class

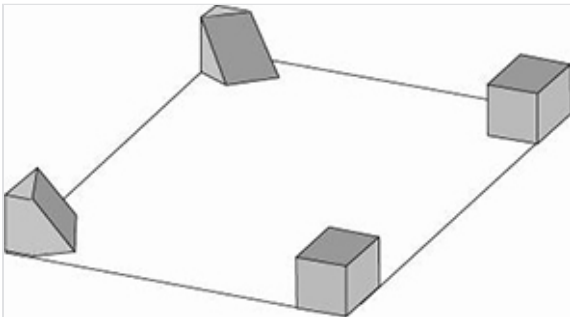

The DEDRA 600 gratings use the stability principle "2 oblique supports + 2 plane supports".

Schematization of the stability principle



Position of the supports on the frame

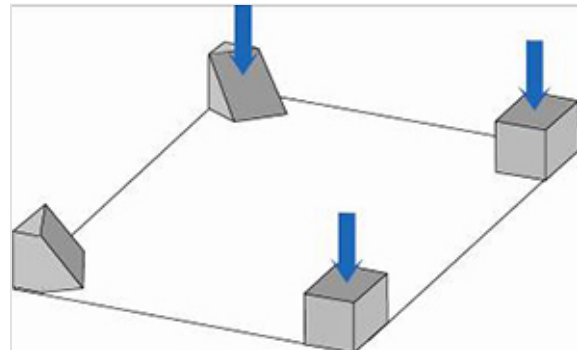

Application of the solicitations

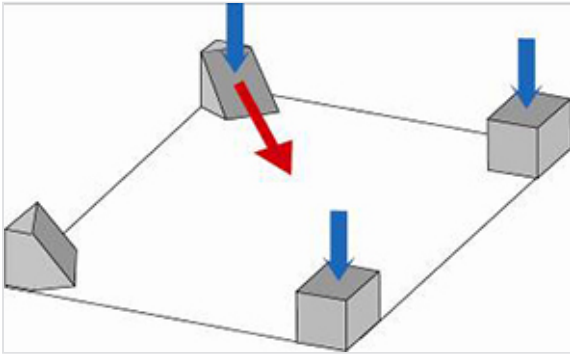

Reaction on first oblique support

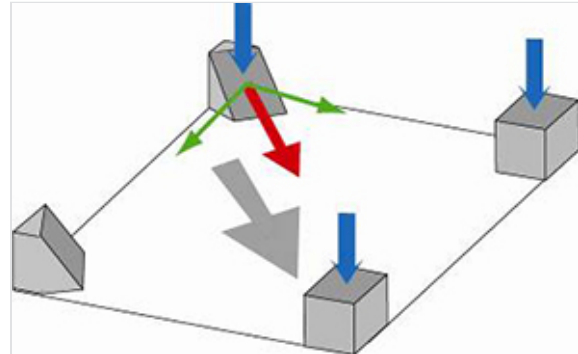

Positioning of the grating

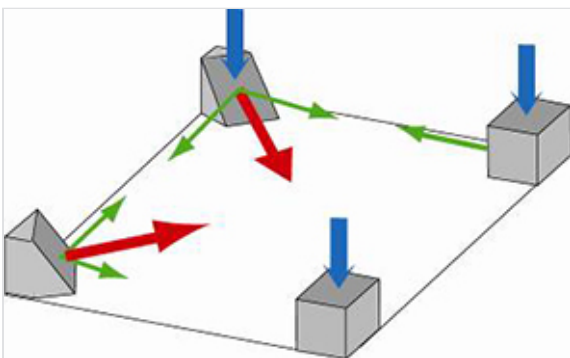

Reaction on second oblique support and plane support

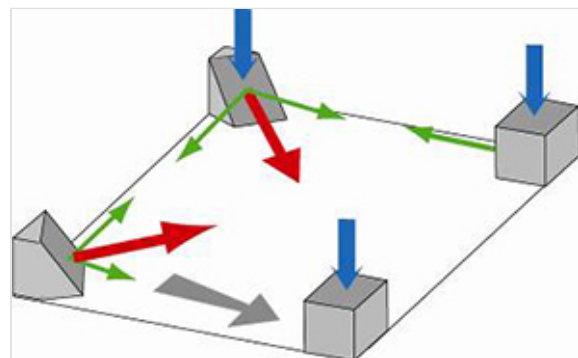

Positioning of the grating

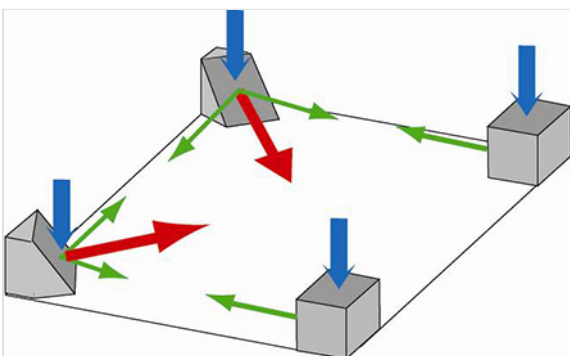

Reaction on second plane support = equilibrium

Legend:

Blue arrow: Solicitations generated by the traffic.

Red arrow: Reaction force of the supports.

Green arrow: Resultant of the reaction forces.

Grey arrow: Positioning of the grating [Weak displacements to find stable supports].

The spring bar is not in permanent tension (passive bar) because it must not be opposed to the light displacement of the grating so that this one finds its supports.

The information on this sketch is, to the best of our knowledge correct at the time of printing. However Saint-Gobain are constantly looking at ways of improving their products and services therefore reserve the right to change without prior notice, any of the data shown. Any orders placed will be subject to our Standard Conditions of Sale, available on request.