

Inspection Tee

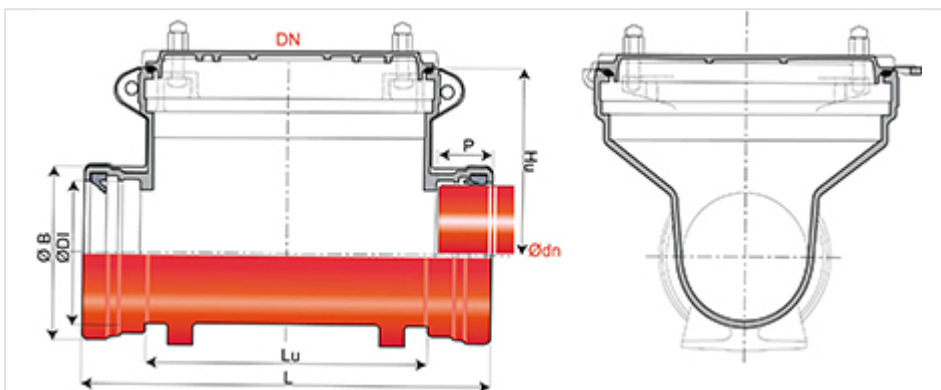

DN (mm)	Ødn (mm)	Lu (mm)	L (mm)	ØDI (mm)	ØB (mm)	P (mm)	Hu (mm)	Mass (kg)	References
400	150	514	694	175	219	90	289	66	TJB15PD0J-E06
400	200	475	655	226	273	90	289	67.5	TJB20PD0K-E06
400	250	521	721	283.5	317	100	283	75	TJB25PD0L-E06
400	300	455	675	337.5	386	110	283	79.5	TJB30PD0M-E06

Reference of the accessories : Cover without counterweight lever : TJB15PU - "O" Ring for cover : 144002



Main characteristics:

- External and internal coating: red epoxy powder 250µm (PECR)
- EN 598 / CE Marking
- Declaration of performances [DoP-INTEGRAL005EN](#)
- Mark NF
- Designed according to the regulatory texts:
 - NF EN 476: general prescriptions for components used in the networks
 - NF EN 752: Conception of sewage projects
 - NF EN 1610: Reception of the works
 - CCTG: Fascicule 70 (sewage work)
- IM joints included (collector)
- "O" ring DN12mm included (cover)

Field of use:

- Ensures gravity pipe leak tightness as it passes through the manhole and also allows cleaning and inspection equipment to be inserted.
- Use: 2 bar maximum
- Waste water

Linked products



IM Seal for gravity fittings

The information on this sketch is, to the best of our knowledge correct at the time of printing. However Saint-Gobain are constantly looking at ways of improving their products and services therefore reserve the right to change without prior notice, any of the data shown. Any orders placed will be subject to our Standard Conditions of Sale, available on request.