

QUICK PVC/PE anchored

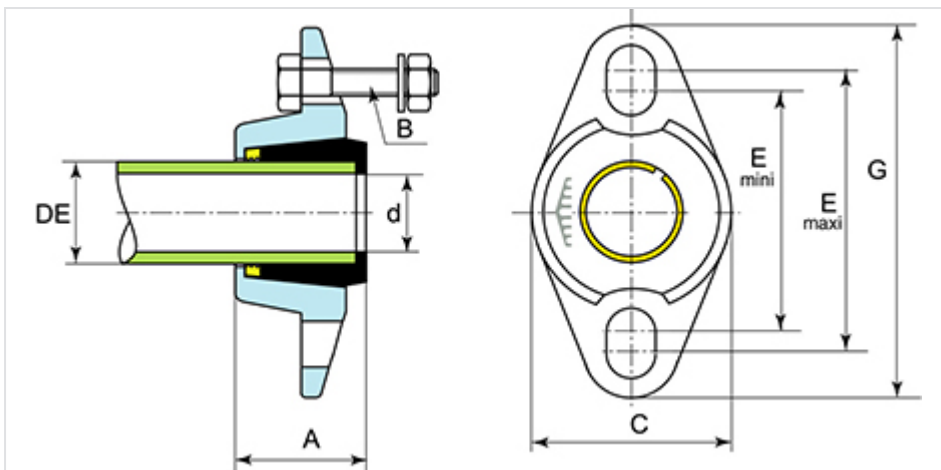

DN flange (mm)	DN/OD (mm)	ØDE (mm)	E mini (mm)	E maxi (mm)	G (mm)	d (mm)	A (mm)	Bolts	K (mm)	Mass (kg)	References
15/20	25	25	65	75	104	19	37	HM12/50	55	0.40	MAL25DACH
20/25	32	32	75	85	114	25	41	HM12/50	62	0.50	MAL32DACH



Material and coatings

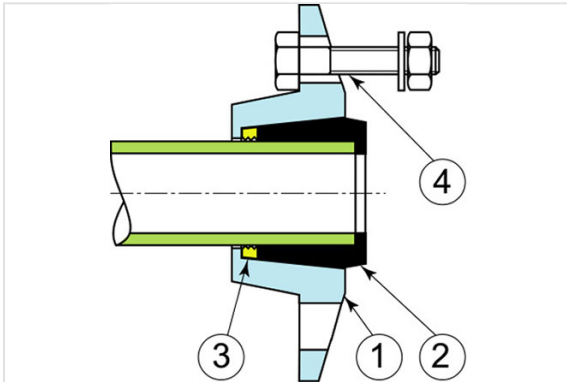

Item	Designation	Material	Coating
1	Flange	Ductile Iron	Epoxy paint
2	Joint	EPDM	
3	Anchoring ring	Brass	
4	Bolt with washer	Steel	Galvanised

The information on this sketch is, to the best of our knowledge correct at the time of printing. However Saint-Gobain are constantly looking at ways of improving their products and services therefore reserve the right to change without prior notice, any of the data shown. Any orders placed will be subject to our Standard Conditions of Sale, available on request.