

Underground Fire Hydrant MODEL FLAMANDE DN80 with Duckfoot Bend

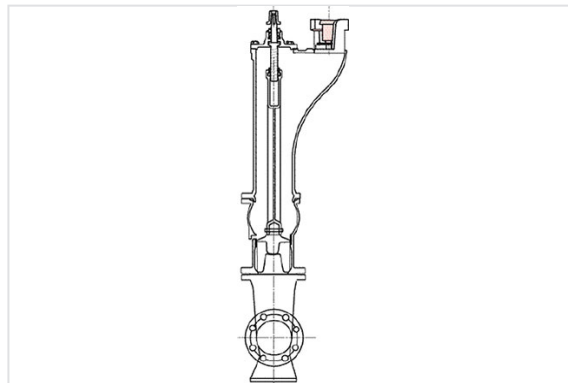

The Underground Fire Hydrant is integrated in a discrete way in an urban environment.

Its essential characteristics are:

- Body in ductile iron
- Epoxy coating
- Square Operating cap NBN 17 x 17 mm
- Outlet : bayonet According to NBN S 21034
- Automatic drainage function

DN (mm)	HC (mm)	H2 (mm)	H4 (mm)	H5 (mm)	A (mm)	C (mm)	Mass (kg)
80	1000	755	1030	745	180	145	29

(*) consult us

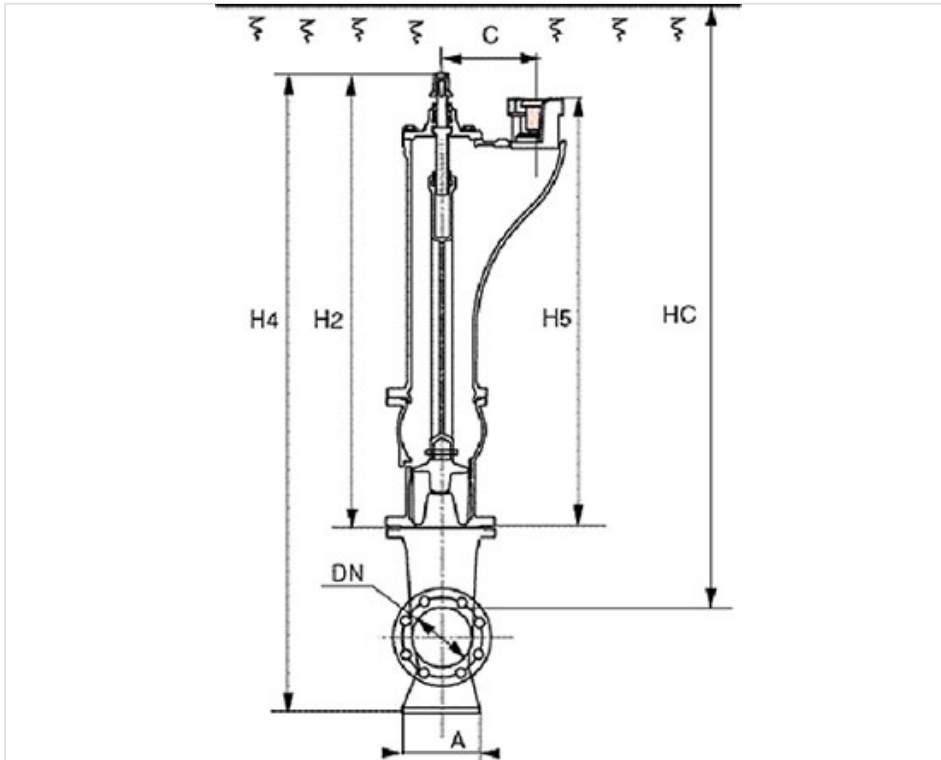

Field of use

Fire hydrants pillar or underground type are designed, according to applicable standards and regulations, for exclusive use of fire protection and using drinking water or raw water network.

They must be handled and used in strict compliance with the recommendations and best practice by personnel trained with these recommendations.

These devices must be inspected periodically (as required by regulations or recommended instructions) to verify and maintain their proper and safe operation.

Material and coatings

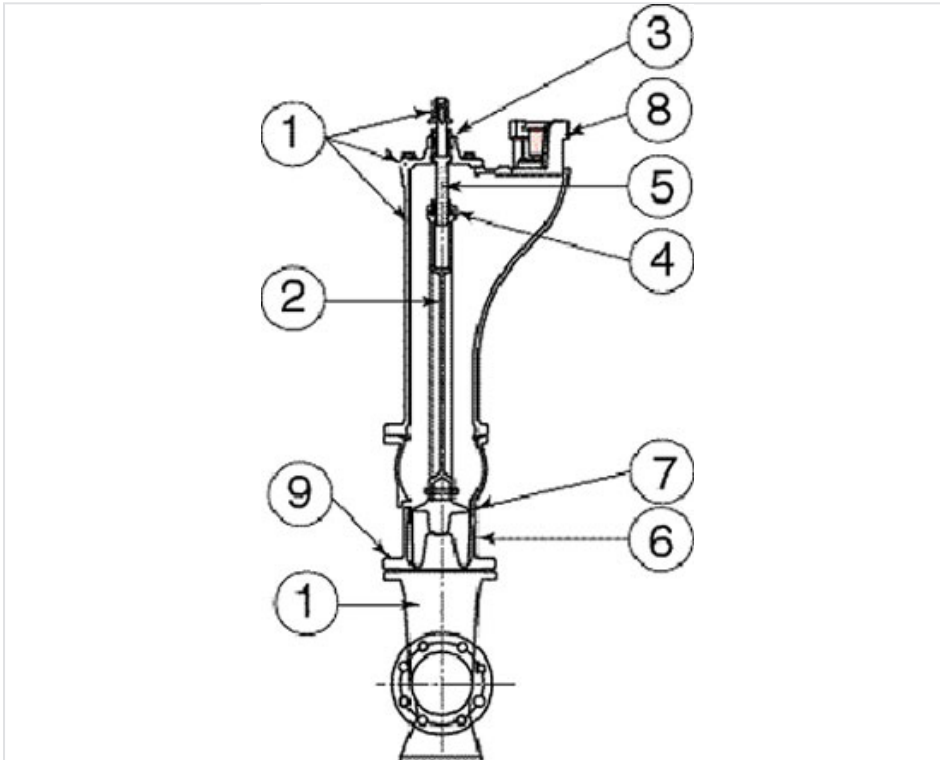

Item	Designation	Material	Coating
1	Body-cover - Operating cap - Duckfoot bend	Ductile iron	Fusion bonded epoxy thickness mini: 250 microns
2	Operating rod		
3	Bush	Brass type	
4	Stem nut	Cu Zn 39	
5	Stem	St. steel type Z 20 C 13	
6	Wedge	Ductile Iron + EPDM rubber	
7	Seat	Bronze type CuSn7	
8	NBN Outlet	Ductile iron	Epoxy 250 microns
9	Bolting	Stainless steel	

Technical characteristics

- 13 turns to close
- Duckfoot bend mobile flange
- Bolting between body and duckfoot bend in stainless steel
- Bolt and washer type A2 and nut type A4

The information on this sketch is, to the best of our knowledge correct at the time of printing. However Saint-Gobain are constantly looking at ways of improving their products and services therefore reserve the right to change without prior notice, any of the data shown. Any orders placed will be subject to our Standard Conditions of Sale, available on request.