

Butterfly Valve EUROSTOP LM - Manual and with actuator



BUTTERFLY VALVE WITH INTEGRATED DISMANTLING JOINT

Butterfly valve with integrated 3-flange type dismantling joint suitable for installation of the two elements in the pipeline at the same time (valve and joint), which results in a significant reduction in assembly time. The valve/joint assembly is delivered already in a suitable position for installation, in the intermediate resting condition.

The joint is divided into three parts (1-2-3): flanges are drilled according to EN1092; the parts are joined together by tightening

threaded tie bars (5). The valve with the integrated joint is tested on the bench after assembly.

To ensure tightness, the joint is equipped with an elastomeric gasket (4) positioned between the seal pressing ring (2) and the fixed sleeve of the valve body (1).

Range

The following sizes are available: DN300-400-500-600 PN10-16.

DN (mm)	Version	PN	L1 (mm)	L2 (mm)	D5 (mm)	D4 (mm)	Number of holes	M (mm)	Mass - Manual version (kg)	Mass - Version with actuator (kg)	Mass - Motorised version (kg)	References
300	Manual	10	523	390	455	400	12	M20	134.00	134	152	261639
300	Manual	16	523	410	455	410	12	M24	139.00	141	162	261640
300	Motorized	10	523	390	455	400	12	M20	134.00	134	152	261648
300	Motorized	16	523	410	455	410	12	M24	139.00	141	162	261649
400	Manual	10	584	420	565	515	16	M24	216.00	216	238	261641
400	Manual	16	584	450	580	525	16	M27	263.00	263	285	261642
400	Motorized	10	584	420	565	515	16	M24	216.00	216	238	261650

BUTTERFLY VALVES EUROSTOP ISOLATING VALVES DN 300 - 600

10/06/2026
VIGBV21MAN090

DN (mm)	Version	PN	L1 (mm)	L2 (mm)	D5 (mm)	D4 (mm)	Number of holes	M (mm)	Mass - Manual version (kg)	Mass - Version with actuator (kg)	Mass - Motorised version (kg)	References
400	Motorized	16	584	450	580	525	16	M27	263.00	263	285	261651
500	Manual	10	644	440	670	620	20	M24	316.00	316	338	261643
500	Manual	16	644	500	715	650	20	M30	446.00	454	475	261644
500	Motorized	10	644	440	670	620	20	M24	316.00	316	338	261652
500	Motorized	16	644	500	715	650	20	M30	446.00	454	475	261653
600	Manual	10	685	460	780	725	20	M27	449.00	457	479	261645
600	Manual	16	685	500	840	770	20	M33	624.00	627	650	261646
600	Motorized	10	685	460	780	725	20	M27	449.00	457	479	261654
600	Motorized	16	685	500	840	770	20	M33	624.00	627	650	261655

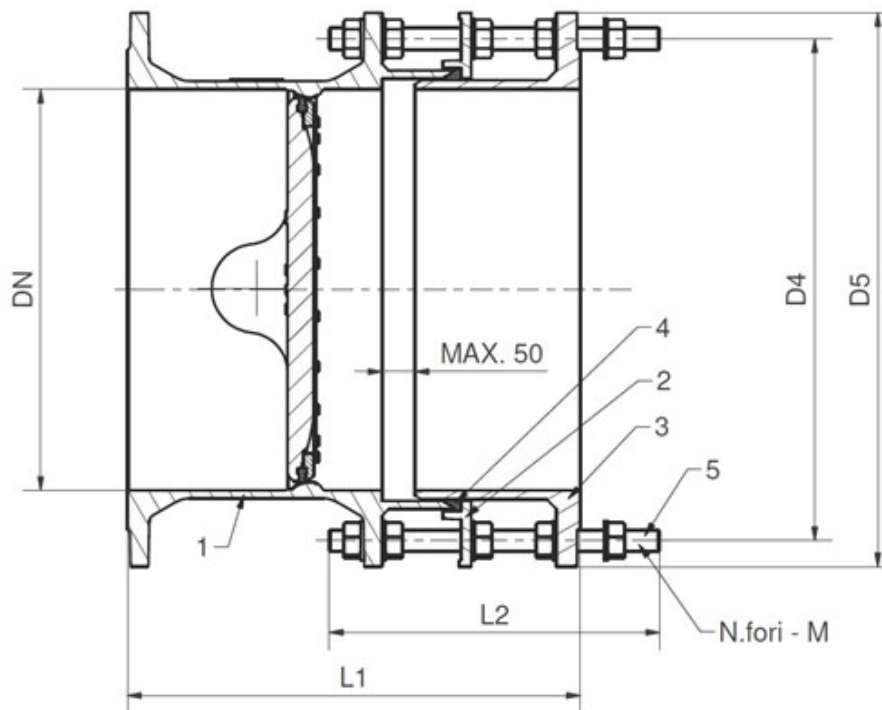

Materials

Item	Description	Material	Coating
1	Butterfly valve	Refer to technical data sheet	
2	Seal press ring	Ductile iron EN GJS 400-15	Epoxy painting RAL 5005, min.thickness 250 microns
3	Sliding sleeve	Ductile iron EN GJS 400-15	Epoxy painting RAL 5005, min. thickness 250 microns
4	Gasket	EPDM	
5	Tie bars	Steel S235JR	Dacromet

Regulations

Hydraulic test

Each butterfly valve is submitted to pressure test on a hydraulic test bench before leaving the factory, in compliance with EN 12266-1 and EN1074:

- Body resistance and leak test to 1.5 times allowable operating pressure (open valve);
- Leak test on body sides of the disc to 1.1 times allowable operating pressure (open valve).

Tests on the product

- Check of maximum operating torque (MOT) and minimum allowable strength torque (mST) according to EN1074.
- Check of painting: thickness test, holiday test, impact test, MIBK test. Compliance with EN 14901 regulation.

Compliance with regulations

Product:

- EN 1074 - 1 and 2
- EN 593

Factory testing:

- EN 12266-1 (ISO 5208)
- EN 1074

Face to face dimensions in compliance with:

- ISO 5752 series 14

Drilling of connection flanges:

- EN 1092-2
- ISO 7005-2

Control unit connection:

- ISO 5210
- ISO 5211

Marking



Body marking according to EN19:

- Nominal diameter in mm (DN);
- Nominal pressure in bar (PN);
- Type of ductile iron;
- Manufacturer logo;
- Model code;
- Melting date.

On the label according to EN19:

- Nominal diameter in mm (DN);
- Nominal pressure in bar (PN);
- Allowable operating pressure (PFA);
- Closing direction;
- Product code;
- Work order, Order confirmation;
- Manufacturer mark.

On the disc:

- Nominal diameter in mm (DN);
- Nominal pressure in bar (PN);
- Type of ductile iron;
- Manufacturer logo;
- Model code.

The marking of the valves manufactured by Saint-Gobain PAM complies with EN 1074-2 and EN 19.

The markings can be integrally cast with the body, or they can be marked on metal plates or labels securely fixed to the body, according to EN 19 specifications.

Specifications EN19			Saint-Gobain valves process
Table1-Valve markings		Requirements	
1	DN	EN 19 § 4.2.1 Mandatory markings must be integrally cast or marked on a metal label	Integrally cast
2	PN		Integrally cast
3	Material		Integrally cast
4	Manufacturer's name or logo		Plate
11	Reference to Standard	EN 19 § 4.3 Additional marking Items 7 to 21 in Table 1 are optional	Integrally cast
12	Casting identification		Integrally cast
16	Quality test		Marked on the body
18	Manufacturing date		Plate
21	Closing direction		Plate + sticker on the body

Size

The butterfly valves are generally used as isolating devices type on/off. In some particular case, in which there's low differences of pressure and low flow rate variation can be used like regulating devices, considering the hydraulic parameters necessary to avoid the cavitation risk.

To do the right dimensioning of butterfly valve it's necessary to know the followings parameters:

- Upstream hydrostatic pressure (that is the hydrostatic pressure with valve in closed position)
- The maximum speed in water pipe (generally expressed in l/s) or the nominal diameter and the project flow rate from which it is gained the speed $V=Q/A$

Moreover it's necessary to control that the maximum speed in water pipe have to be equal or inferior to 5m/s, and the exercise temperature have to be between 0°C and 40 °C.

Hydraulic features

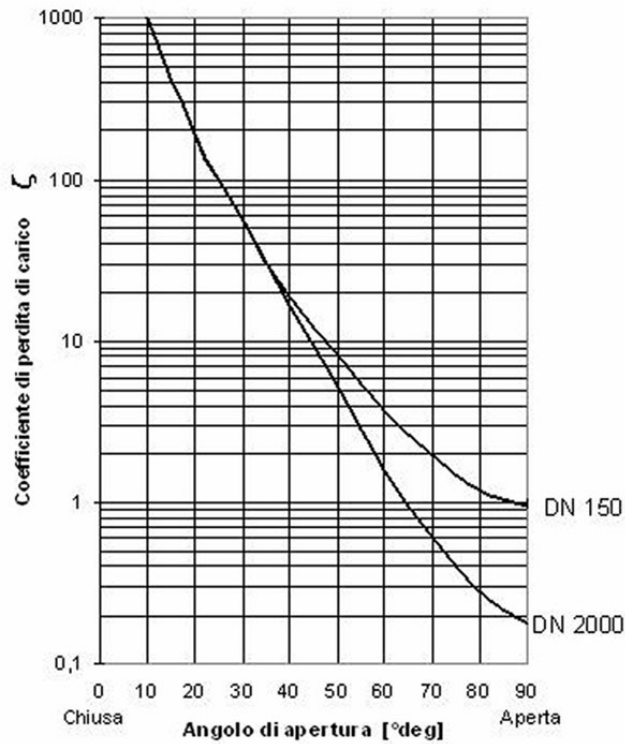

VALVOLA A FARFALLA - BUTTERFLY VALVE

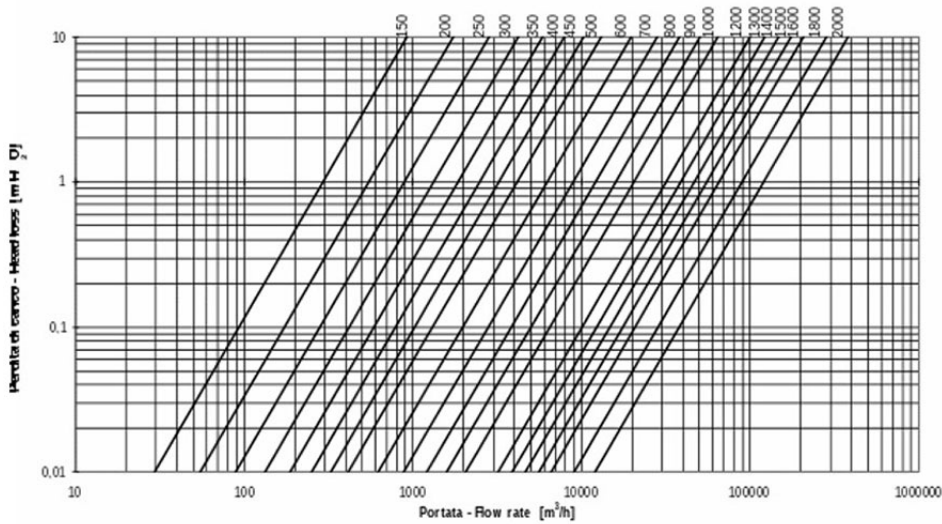
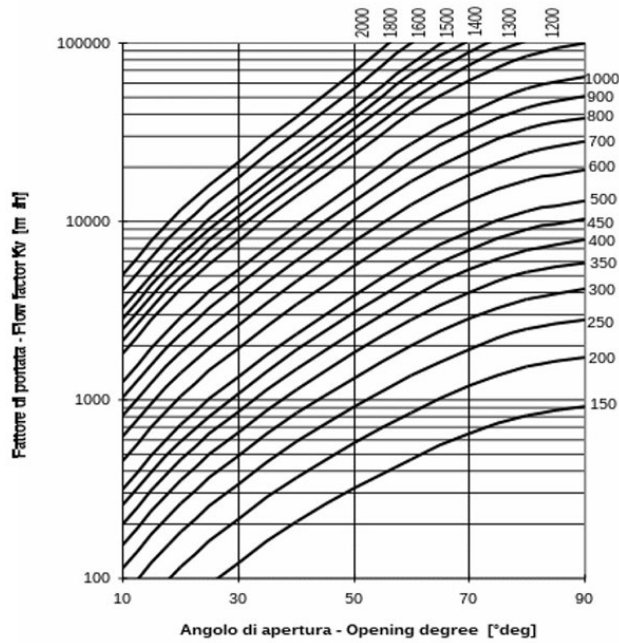

The head loss Δh are variable in function of valve open degree and can be calculated with the following expression:

with Δh = head loss (m), ζ = head loss coefficient (dimensional), v = nominal speed (m/s), $g = 9,81$ (m/s²)

$$\Delta H = \frac{\zeta \cdot v^2}{2 \cdot g}$$

The head loss coefficient can be estimated based on the first diagram.

Determinates the head loss Δh it's possible to calculate the flow rate Q in m^3/h with the following expression (the same expression can be used to, having the project flow rate Q , to determinate the head loss Δh without using the head loss coefficient):

$$Q = K_v \sqrt{\frac{\Delta h}{10,2}}$$

in which 10,2 is a corrective factor in meters, and K_v is the flow rate coefficient in m^3/h , determinable in the second diagram in function of valve open degree.

Example: Valve DN600 mm - $\Delta h = 3$ m

From the previous diagram K_v can be obtained = 20000 m^3/h . - with valve 100% open- by entering data in the previous formula:

$$Q = 2000 \times \sqrt{\frac{3}{10,2}} = 10850 \text{ m}^3/h$$

Alternatively, head losses can be calculated when the valve is fully open if the design flow rate Q is known, as a function of the DN diameter, using the last diagram.

Cavitation

If the butterfly valve is only used as a shut-off device, there is no risk of cavitation.

It is possible to use it for adjustment, if the following parameters are considered:

- The opening angle of the valve must remain between 30° and 90° (valve fully open).
- Downstream pressure P_2 in meters of water column must be:

$$P_2 \geq 0,7 \cdot P_1 - 2,8$$

with P_1 upstream pressure.

Instructions for use

Storage

If possible, the butterfly valve must be located in covered places, as far away as possible from the sun (maximum allowed temperature of 70 °C according to EN 1074), rain and atmospheric agents in general. In addition, the sealing gasket of the valves must be prevented from coming into contact with dust or soil.

Installation

The valve is bidirectional. However, it is advisable to install the valve with the operating element on the hydraulic right side of the pipeline.

The dismantling joint is in the intermediate rest position, allowing the installer to extend it further if necessary. Do not compress it during installation to allow future axial travel, which proves useful for the maintainer to disassemble the valve.

Maintenance

The butterfly valve does not need particular maintenance, all parts subject to wear are in fact perfectly self-lubricating.

However, if it remains unused for a long time, it is necessary to check its conditions by performing some opening and closing operations at least once a year.

All maintenance operations must be carried out after the pipeline has been completely emptied (total absence of flow and zero pressure) to avoid any danger to people during these operations.

In the presence of particular operating conditions or damage due to external causes, some maintenance operations may still be necessary. In these cases, the particular construction of the butterfly valve Eurostop allows the gasket to be easily replaced.

Accessories

To adapt the butterfly valves to the different operating and installation conditions, they can be equipped with special accessories in combination with control devices: refer to the data sheet for accessories.

The technical specifications in this document are not contractual and may be changed without notice due to continuous technical progress of the product.

Linked products



Operation and
maintenance instructions
for Eurostop butterfly
valve

The information on this sketch is, to the best of our knowledge correct at the time of printing. However Saint-Gobain are constantly looking at ways of improving their products and services therefore reserve the right to change without prior notice, any of the data shown. Any orders placed will be subject to our Standard Conditions of Sale, available on request.