

## Air Inlet check valve

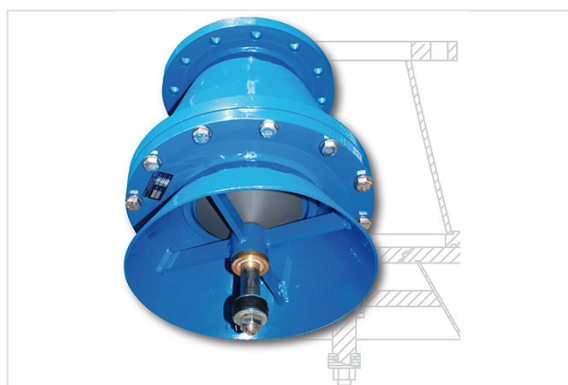

DN (mm)	PN	A (mm)	B (mm)	C (mm)	E (mm)	H (mm)	L (mm)	Mass (kg)	References
80	10	260	470	500	360	550	330	22.00	RCA80LABH
80	16	260	470	500	360	550	330	24.00	RCA80LAAH
80	25	260	470	500	360	550	330	26.00	RCA80LADH
80	40	260	470	500	360	550	330	28.00	RCA80LAEH
100	10	284	560	550	450	600	413	26.00	RCB10LABH
100	16	284	560	550	450	600	413	28.00	RCB10LAAH
100	25	284	560	550	450	600	413	31.00	RCB10LADH
100	40	284	560	550	450	600	413	35.00	RCB10LAEH
150	10	350	780	760	610	1150	434	38.00	RCB15LABH
150	16	350	780	760	610	1150	434	40.00	RCB15LAAH
150	25	350	780	760	610	1150	434	42.00	RCB15LADH
150	40	350	780	760	610	1150	434	52.00	RCB15LAEH
200	10	420	980	1150	825	1550	457	56.00	RCB20LABH
200	16	420	980	1150	825	1550	457	60.00	RCB20LAAH
200	25	420	980	1150	825	1550	457	64.00	RCB20LADH
200	40	420	980	1150	825	1550	457	68.00	RCB20LAEH
250	10	480	1200	1450	1010	1650	497	63.00	RCB25LABH
250	16	480	1200	1450	1010	1650	497	67.00	RCB25LAAH
250	25	480	1200	1450	1010	1650	497	71.00	RCB25LADH
250	40	480	1200	1450	1010	1650	497	79.00	RCB25LAEH

DN (mm)	PN	A (mm)	B (mm)	C (mm)	E (mm)	H (mm)	L (mm)	Mass (kg)	References
300	10	540	1260	1500	1110	1780	520	92.00	RCB30LABH
300	16	540	1260	1500	1110	1780	520	98.00	RCB30LAAH
300	25	540	1260	1500	1110	1780	520	105.00	RCB30LADH
300	40	540	1260	1500	1110	1780	520	112.00	RCB30LAEH
350	10	680	1310	1560	1280	1835	430	122.00	RCB35LABH
350	16	680	1310	1560	1280	1835	430	132.00	RCB35LAAH
350	25	680	1310	1560	1280	1835	430	136.00	RCB35LADH
350	40	600	1310	1560	1280	1835	580	145.00	RCB35LAEH
400	10	730	1420	1650	1410	2115	480	172.00	RCB40LABH
400	16	730	1420	1650	1410	2115	480	186.00	RCB40LAAH
400	25	730	1420	1650	1410	2115	480	198.00	RCB40LADH
400	40	680						210.00	RCB40LAEH

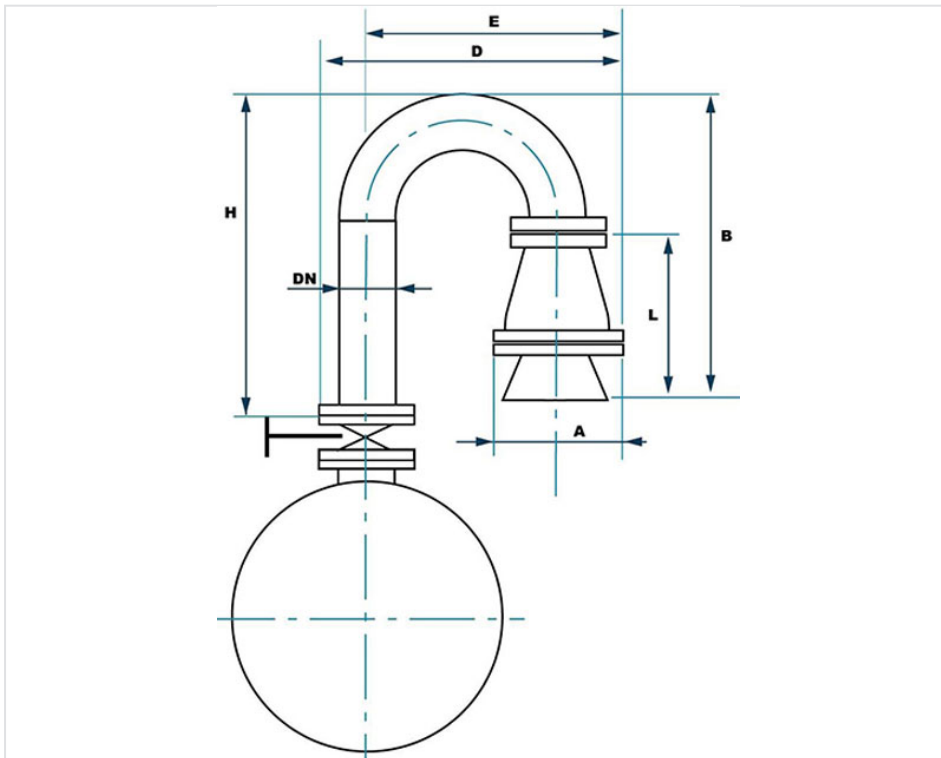

The purpose of the Air Inlet Check Valve is to permit a high flow air intake into the pipe, in order to prevent negative pressure, the result of which would be damage to the sealing joints and a risk of the pipe being crushed. It provides a normal flow during pipe draining.

Generally speaking, the choice of the ND of the air inlet check valve is based on an admissible negative pressure in the pipe of 2 meters water column. We then apply a ratio between the air flow in L/s and the cross section of the passage of the air inlet check valve, in dcm<sup>2</sup> equal to 1900.

This figure is constant whatever the ND for the air inlet check valve, since it is given by the maximum velocity of air input which is 1900 dcm/s, that is 190m/sec.

We obtain maxi. air input flow rates for a negative pressure of 2m/wc. to:

DN (mm)	80	100	150	200	250	300	250	400
L/s	792	1236	2782	4945	7727	11127	15145	19782

When the negative pressure reaches 3, 4 or 5 m/wc, see table below:

DN	Air speed in Subsonic mode				Air speed in Sonic mode
	118,4m/s	157,5 m/s	179,9 m/s	191,5 m/s	195 m/s
mm	ELIGIBLE LOW BAR PRESSURE RELATING TO THE NATURE OF PIPE MATERIALS				
	-0,1	-0,2	-0,3	-0,4	-0,5
80	595 L/s	792 L/s	894 L/s	962 L/s	980 L/s
100	929 L/s	1236 L/s	1412 L/s	1503 L/s	1530 L/s
150	2091 L/s	2782 L/s	3177 L/s	3382 L/s	3444 L/s
200	3718 L/s	4945 L/s	5648 L/s	6013 L/s	6123 L/s
250	5809 L/s	7727 L/s	8826 L/s	9395 L/s	9567 L/s
300	8364 L/s	1127 L/s	12710 L/s	13529 L/s	13776 L/s
350	11385 L/s	15145 L/s	17300 L/s	18415 L/s	18751 L/s
400	14871 L/s	19782 L/s	22595 L/s	24052 L/s	24492 L/s
500	23236 L/s	30909 L/s	35305 L/s	37581 L/s	38268 L/s

The air speed does not exceed 195m / s (speed of sound), this is due to a blockage of the mass flow at the level of the passage of the valve section. Note that the active section of the air passage is equal to the DN of the SNH valve, for example on a flanged valve DN 200 the air inlet section at the level of the valve seal marked N ° 3 is equal to 200mm.

## Choice of diameter

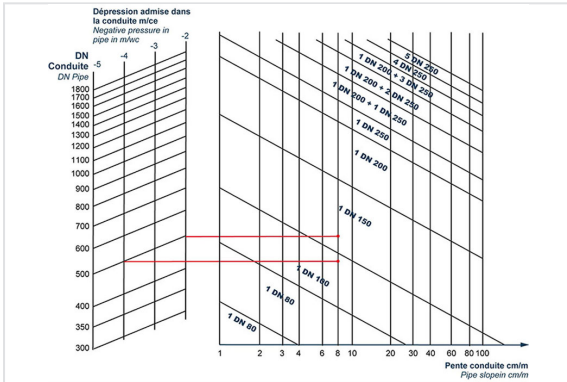

Abacus enabling the choice of the ND of the air inlet check valve

*Example:*

1. For a 500mm pipe, with a tolerated negative pressure of 4m/wc, the maximum slopes on each side of the point in consideration being 8 cm/m, we choose the ND100.
2. For a 500mm pipe, with a tolerated negative pressure of 2 m/wc, the maximum slopes on each side of the point in consideration being 8 cm/m, we choose the ND150.

## Material and coatings

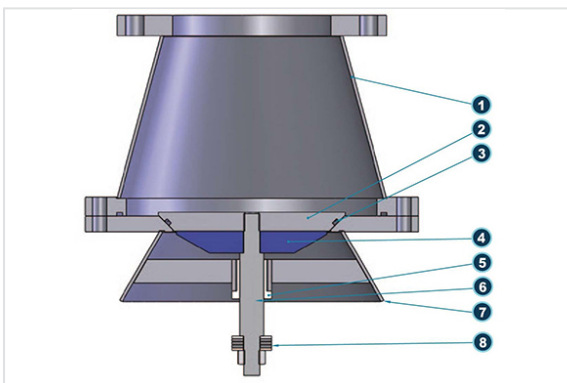

Item	Item	Material	Material
1	Body	S235 Steel	Protection Epoxy 200 microns oven baked 200°C - RAL 5015 Blue
2	Clapper	S235 Steel	Protection Epoxy 200 microns oven baked 200°C - RAL 5015 Blue
3	Clapper joint	NBR	
4	Deflection cone (*)	PVC	
5	Bearing	Bronze UE7	

Item	Item	Material	Material
6	Clapper spindle	316L St. Steel	
7	Inlet cone	S235 Steel	Protection Epoxy 200 microns oven baked 200°C - RAL 5015 Blue
8	Damper washer	NBR	

\* Deflection cone (4) present from DN200

## Compliance with standards

The Air Inlet check valve conforms to standard EN 1074 -1 & 4.

Minimum and maximum operating temperature: 0 to 70° C.

Minimum sealing pressure: 0.1 bar.

Permissible operating pressure (PFA) 10/16/25/40 bars depending on model.

Certificate of sanitary Conformity (ACS).

## Installation

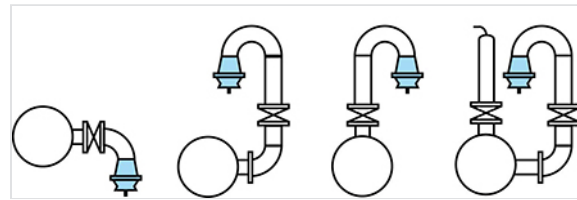
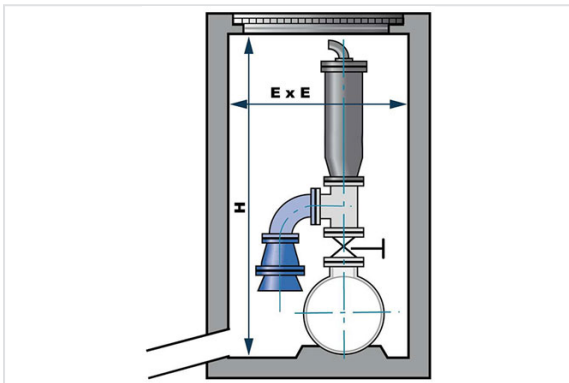

The air inlet check valve is installed in a valve chamber (see diagram) sufficiently ventilated by an upper grill cover.

It is recommended to fit a stop valve, which allows an eventual dismantling of the appliance, without having to close down the operation of the circuit.

It must be placed in a vertical position, at a height well above the pipe (see diagram) in order to prevent the sucking in of foreign matter into the pipe.

DN	E x E	H
80	1000 x 1000	2000
100	1000 x 1000	2000
150	1200 x 1200	2000

DN	E x E	H
200	1500 x 1500	2200
250	2000 x 2000	2500
300	2150 x 2100	2580
350	2200 x 2150	2600

*The information on this sketch is, to the best of our knowledge correct at the time of printing. However Saint-Gobain are constantly looking at ways of improving their products and services therefore reserve the right to change without prior notice, any of the data shown. Any orders placed will be subject to our Standard Conditions of Sale, available on request.*