

Needle valve E508 NGL



Fields of application

The main characteristic of needle valve is the capacity to modulate water flow rate and elevated differential pressure. The needle valve NGL is able to do a linear manoeuvre also in a presence of relevant partialization degree although high inlet pressure and big exercise difference of pressure. The possibility to be actuated by electrical devices permit to use this valve in combination with control system to realize multiple function.

The needle valve controls the water flow rate through the axial movement of a shutter operated by a connecting-rod and crank mechanism. The inlet flow rate is channeled into a round section passage which gradually decreasing and then increasing from the intake to the sealing seat.

The internal profile of the valve is designed to optimize the hydrodynamic profile in order to have:

- low head losses whit valve completely open
- minimize cavitation phenomena in case of big differences between inlet and outlet pressures of valve. In this case the valve can be equipped with a special stainless steel cylinder for hydraulic loads dissipation

Range

The needle valve E508 NGL is proposed in standard versions:

- Manual or motorized (with handwheel)
- DN100 to 1000
- Without anti-cavitation cylinder

Manual/motorizable Version

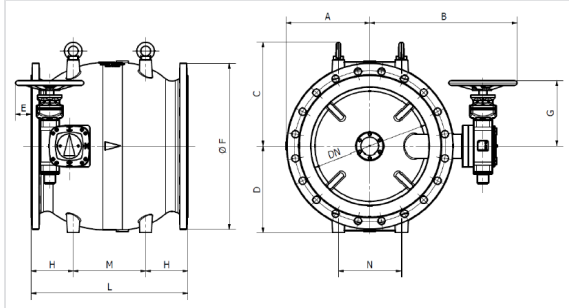

Motorized Version

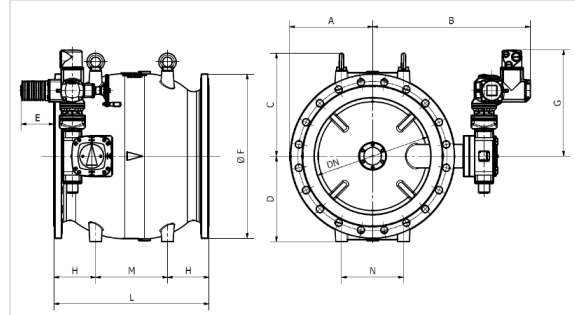

Dimensions

Manual/motorizable Version

PN10

DN	A	B	G	D	E	F	L	M	N	H	C	Mass
mm	mm	mm	mm	mm	mm	mm	mm	mm	mm	mm	mm	kg
100	117,5	300	134	122	50	235	300	140	90	80	167	44
150	150	335	134	155	40	300	350	160	110	95	200	71
200	170	405	169	185	58	340	400	170	150	115	230	103
250	198	440	169	218,5	53	395	450	200	170	125	263.5	150
300	226	470	169	250	53	445	500	230	200	135	295	198
400	299	557	174	320	50	565	600	280	240	160	382	344
500	363	690	303	376	100	670	700	330	316	185	438	582
600	428	750	303	440	80	780	800	370	320	215	530	808
700	492	845	308	510	85	895	900	440	440	230	600	1153
800	555	910	308	570	80	1015	1000	500	500	250	660	1486
900	622	1010	384	640	95	1115	1100	550	550	275	730	2142
1000	689	1075	384	710	75	1230	1200	600	600	300	800	2742
1200	833	1240	384	860	35	1485	1400	700	700	350	988	4126
1400	960	1390	609	1000	145	1685	1600	800	800	400	1128	5677
1600	1085	1575	514	1100	75	1930	1800	900	900	450	1233	7550

PN16

DN	A	B	G	D	E	F	L	M	N	H	C	Mass
mm	mm	mm	mm	mm	mm	mm	mm	mm	mm	mm	mm	kg
100	117,5	300	134	122	50	235	300	140	90	80	167	44
150	150	335	134	155	40	300	350	160	110	95	200	71

DN mm	A mm	B mm	G mm	D mm	E mm	F mm	L mm	M mm	N mm	H mm	C mm	Mass kg
200	170	405	169	185	58	340	400	170	150	115	230	102
250	203	440	169	218,5	53	405	450	200	170	125	263.5	151
300	230	472	173	250	70	460	500	230	200	135	295	202
400	299	625	303	320	120	580	600	280	240	160	382	372
500	363	690	303	376	100	715	700	330	316	185	438	604
600	428	750	303	440	80	845	800	370	320	215	530	855
700	492	845	308	510	85	910	900	440	440	230	600	1161
800	555	910	308	570	80	1025	1000	500	500	250	660	1490
900	622	1010	384	640	95	1125	1100	550	550	275	730	2146
1000	689	1075	384	710	75	1255	1200	600	600	300	800	2769
1200	833	1240	514	860	75	1485	1400	700	700	350	988	4290
1400	960	1390	514	1000	75	1685	1600	800	800	400	1128	5665
1600	1085	1575	514	1100	75	1930	1800	900	900	450	1233	7550

PN25

DN mm	A mm	B mm	G mm	D mm	E mm	F mm	L mm	M mm	N mm	H mm	C mm	Mass kg
100	117,5	300	134	122	50	235	300	140	90	80	167	44
150	150	365	169	155	78	300	350	160	110	95	200	77
200	180	405	169	185	58	360	400	170	150	115	230	104
250	213	442	174	218,5	70	425	450	200	170	125	263.5	158
300	243	472	174	250	70	485	500	230	200	135	295	207
400	310	625	303	320	120	620	600	280	240	160	382	385
500	365	690	308	376	125	730	700	330	316	185	438	616
600	428	750	308	440	105	845	800	370	320	215	530	859
700	492	845	308	510	85	960	900	440	440	230	600	1201
800	555	910	384	570	115	1085	1000	500	500	250	660	1589
900	622	1010	514	640	135	1185	1100	550	550	275	730	2289
1000	689	1075	514	710	115	1320	1200	600	600	300	800	3027

Motorized Version

PN10

DN mm	A mm	B mm	G mm	D mm	E mm	F mm	L mm	M mm	N mm	H mm	C mm	Mass kg
100	117,5	398	388	122	215	235	300	140	90	80	167	63
150	150	433	388	155	205	300	350	160	110	95	200	90
200	170	478	413	185	198	340	400	170	150	115	230	121
250	198	513	413	218,5	193	395	450	200	170	125	263.5	168
300	226	543	413	250	193	445	500	230	200	135	295	216
400	299	630	420	320	208	565	600	280	240	160	382	364
500	363	713	547	376	190	670	700	330	316	185	438	598
600	428	773	547	440	170	780	800	370	320	215	530	825
700	492	868	552	510	175	895	900	440	440	230	600	1170
800	555	933	552	570	170	1015	1000	500	500	250	660	1502
900	622	1033	628	640	185	1115	1100	550	550	275	730	2158
1000	689	1098	630	710	183	1230	1200	600	600	300	800	2761
1200	833	1263	630	860	143	1485	1400	700	700	350	988	4145
1400	960	1413	760	1000	183	1685	1600	800	800	400	1128	5698

PN16

DN mm	A mm	B mm	G mm	D mm	E mm	F mm	L mm	M mm	N mm	H mm	C mm	Mass kg
100	117,5	398	388	122	215	235	300	140	90	80	167	63
150	150	433	388	155	205	300	350	160	110	95	200	90
200	170	478	413	185	198	340	400	170	150	115	230	120
250	203	513	413	218,5	193	405	450	200	170	125	263.5	169
300	230	543	413	250	193	460	500	230	200	135	295	220
400	299	630	420	320	208	580	600	280	240	160	382	390
500	363	713	547	376	190	715	700	330	316	185	438	620
600	428	773	547	440	170	845	800	370	320	215	530	872
700	492	868	552	510	175	910	900	440	440	230	600	1180
800	555	933	552	570	170	1025	1000	500	500	250	660	1508
900	622	1033	628	640	185	1125	1100	550	550	275	730	2164
1000	689	1098	630	710	183	1255	1200	600	600	300	800	2788
1200	833	1263	630	860	143	1485	1400	700	700	350	988	4312
1400	960	1413	760	1000	183	1685	1600	800	800	400	1128	5686

PN25

DN	A	B	G	D	E	F	L	M	N	H	C	Mass
mm	mm	mm	mm	mm	mm	mm	mm	mm	mm	mm	mm	kg
100	117,5	398	388	122	215	235	300	140	90	80	167	62
150	150	438	413	155	218	300	350	160	110	95	200	95
200	180	478	413	185	198	360	400	170	150	115	230	122
250	213	515	418	218,5	210	425	450	200	170	125	263.5	176
300	243	545	420	250	228	485	500	230	200	135	295	227
400	310	648	547	320	210	620	600	280	240	160	382	403
500	365	713	554	376	233	730	700	330	316	185	438	635
600	428	773	552	440	195	845	800	370	320	215	530	876
700	492	868	554	510	193	960	900	440	440	230	600	1220
800	555	933	630	570	223	1085	1000	500	500	250	660	1611
900	622	1033	760	640	243	1185	1100	550	550	275	730	2311
1000	689	1098	760	710	223	1320	1200	600	600	300	800	3049

Material and coating

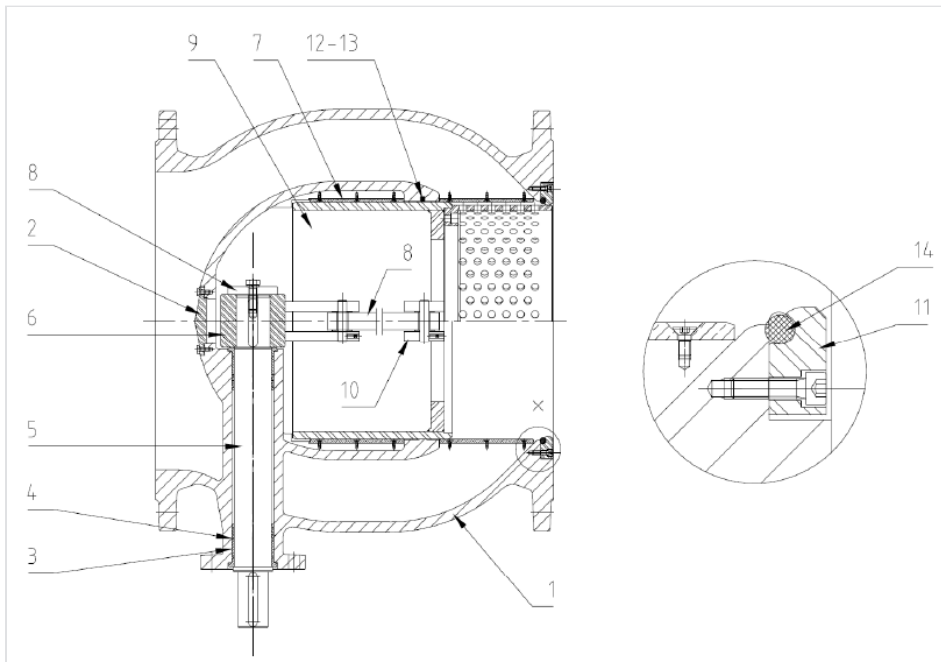

Item	Description	Material	Coating
1	Body	Ductile Iron GS 500-7	Epoxy powder 250µ mini - RAL 5005
2	Cover	AISI 304	
3	Bush	Bronze CuSn12	
4	O-ring	Elastomer EPDM	
5	Shaft	AISI 420	
6	Link Block	AISI 304	
7	Shutter guides	Bronze CuSn8	
8	Rod	AISI 420	
9	Shutter	AISI 304	
10	Fork	AISI 304	
11	Retaining Ring	AISI 304	
12	O-ring	NBR	
13	Sealing Ring	PTFE - Carbographe	
14	Gasket	NBR	
	Anti-cavitation cylinder	AISI 304	
	Internal Screws	AISI 304	
	External Screws	AISI 304	

Gearbox and actuator characteristics

Main features gearbox:

- Non-reversible worm gearbox
- Manufacturer: AUMA / Germany
- Material: Cast iron GG25 according to DIN 1693
- External grey coating: 60 microns thickness, primer and spray coating
- Open-close shutter position indicator
- Enclosure IP68.3 according to EN60529
- Actuation flange ready for optional further fitting of an electric actuator
- Handwheel (for manual version): steel - epoxy coated with 150 microns DFT - direction arrows and words OPEN/SHUT stamped

Main features actuator:

- 3 phases/ 400 V/ 50 Hz squirrel cage AC motor
- Manufacturer: AUMA / Germany
- Modulating service S4 -25% according to CEI / IEC standards
- 2 end-stops switches tandem type
- 2 torque limit switches

- Heater in switch compartment (5-20 W)
- Engageable emergency handwheel
- Electronic position transmitter 4-20 mA
- Enclosure IP67 according to EN60529

On request, it is also possible to configure differently the actuator (f.e. limit switches tandem type, enclosure IP68, etc..) and/or install an integral control unit. The gearbox of manual version valve is equipped with flange for electrical actuator mounting. Below the summary table showing the dimensional and operating features of gearing and electric actuators installed on the valves.

Table: Gearbox & actuator characteristics

DN	PN	Gearbox AUMA type	Number of turns	Operating torque	AUMA actuator	Speed	Closing time
mm				Nm		rpm	s
100	16	GS 50.3 - F10	6.5	9	SAR 07.6	22	18
100	25	GS 50.3 - F10	6.5	14	SAR 07.6	22	18
100	40	GS 63.3 - F10	6.5	23	SAR 07.6	22	18
150	16	GS 50.3 - F10	7.5	16	SAR 07.6	16	28
150	25	GS 63.3 - F12	7.5	24	SAR 07.6	16	28
150	40	GS 63.3 - F12	7.5	38	SAR 07.6	16	28
200	10	GS 63.3 - F12	9.5	14	SAR 07.6	16	36
200	16	GS 63.3 - F12	9.5	22	SAR 07.6	16	36
200	25	GS 63.3 - F12	9.5	33	SAR 07.6	16	36
250	10	GS 63.3 - F12	10.0	22	SAR 07.6	11	54
250	16	GS 63.3 - F12	10.0	33	SAR 07.6	11	54
250	25	GS 80.3 - F12	10.4	47	SAR 07.6	11	56
300	10	GS 63.3 - F12	9.1	31	SAR 07.6	11	50
300	16	GS 80.3 - F12	9.5	44	SAR 07.6	11	52
300	25	GS 80.3 - F12	9.5	67	SAR 10.2	11	52
400	10	GS 80.3 - F14	9.0	53	SAR 10.2	8	67
400	16	GS 100.3/VZ4.3 - F14	35.3	21	SAR 07.6	32	66
400	25	GS 100.3/VZ4.3 - F14	35.3	33	SAR 07.6	32	66
500	10	GS 100.3/VZ4.3 - F16	34.9	21	SAR 07.6	22	95
500	16	GS 100.3/VZ4.3 - F16	34.9	33	SAR 07.6	22	95
500	25	GS 125.3/VZ4.3 - F16	34.9	50	SAR 10.2	22	95
600	10	GS 100.3/VZ4.3 - F16	38.4	19	SAR 07.6	22	105
600	16	GS 100.3/VZ4.3 - F16	38.4	30	SAR 07.6	22	105

DN	PN	Gearbox AUMA type	Number of turns	Operating torque	AUMA actuator	Speed	Closing time
600	25	GS 125.3/VZ4.3 - F16	38.4	44	SAR 07.6	22	105
700	10	GS 125.3/VZ4.3 - F25	36.0	33	SAR 07.6	16	135
700	16	GS 125.3/VZ4.3 - F25	36.0	50	SAR 10.2	16	135
700	25	GS 125.3/VZ4.3 - F25	36.0	77	SAR 10.2	16	135
800	10	GS 125.3/VZ4.3 - F25	35.2	60	SAR 07.6	16	132
800	16	GS 125.3/VZ4.3 - F25	35.2	120	SAR 10.2	16	132
800	25	GS 160.3/GZ 8:1 - F25	74.8	120	SAR 10.2	32	140
900	10	GS 160.3/GZ 8:1 - F30	72.9	60	SAR 07.6	22	199
900	16	GS 160.3/GZ 8:1 - F30	72.9	120	SAR 10.2	22	199
900	25	GS 200.3/GZ 16:1 - F30	142.5	120	SAR 10.2	45	190
1000	10	GS 160.3/GZ 8:1 - F30	73.9	47	SAR 10.2	22	201
1000	16	GS 160.3/GZ 8:1 - F30	73.9	73	SAR 10.2	22	201
1000	25	GS 200.3/GZ 16:1 - F30	144.4	64	SAR 10.2	45	193
1200	10	GS 160.3/GZ 8:1 - F30	76.7	58	SAR 10.2	16	288
1200	16	GS 200.3/GZ 16:1 - F30	149.0	52	SAR 10.2	32	281
1400	10	GS 200.3/GZ 16:1 - F35	149.0	51	SAR 10.2	32	279
1400	16	GS 200.3/GZ 16:1 - F35	149.0	78	SAR 10.2	32	279
1600	10	GS 200.3/GZ 16:1 - F35	149.0	78	SAR 10.2	32	279
1600	16	GS 250.3/GZ 16:1 - F35	146.2	104	SAR 14.2	32	274

Performances and Standards

Hydraulic test

Every single needle valve is subjected to hydraulic final test in according to EN12266 and EN1074:

- Body test at $P_{test} = \max(1,5 \cdot PN ; PEA)$ (opened valve)
- Seat test at $P_{test} = \max(1,1 \cdot PN ; PEA)$ (closed valve)

Product test

Control of coating: thickness control, holiday test, impact test, MIBK test.

Conformity to Standards

Plan test:

- EN 12266
- EN 1074

Flange drilling:

- EN 1092-2

- ISO 7005-2
- Face to face EN-558-1 Serie 15

Control devices connection:

- ISO 5211 for valve-gearbox
- ISO 5210 for gearbox-actuator

Suitability for potable water:

- D.M. 174/04 for applicable parts (ex C.M. 102 of 02/12/1978)
- Foreign conformity: KTW (Germany), WRC (U.K.), ACS (France)

Valve selection

For the right dimensioning and functioning and it is necessary to know the followings hydraulic parameters:

- Hydrostatic downstream pressure (that is the upstream pressure with closed valve)
- Upstream pressure P_{in} and downstream pressure P_{out} with maximum flow rate Q_{max}
- Upstream pressure P_{in} and downstream pressure P_{out} with minimum flow rate Q_{min}

Moreover it's necessary to verify that the maximum speed in the valve have to be equal or inferior to 5m/s and the temperature have to stay between 0°C and 40 °C.

With this parameters is possible to size correctly the valve and evaluate if is necessary to use the anticavitation cylinder, consulting the Technical-Commercial SG PAM department.

Hydraulic features

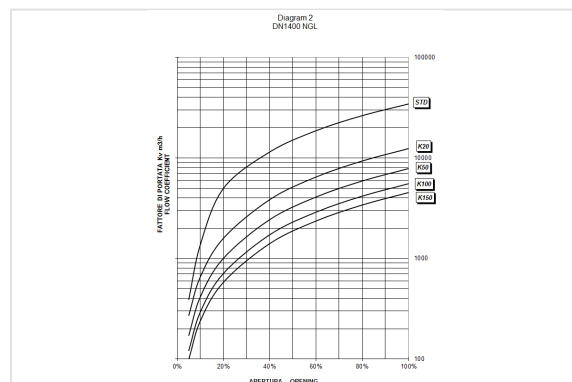
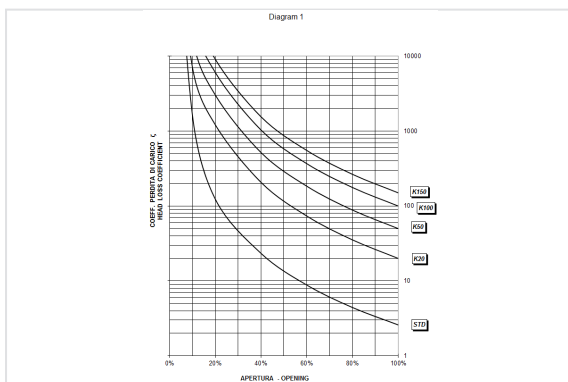

For the calculation of head loss is possible to use the following expression:

$$\Delta H = \frac{\zeta \cdot v^2}{2 \cdot g}$$

in which: Δh = head loss (m.c.a.), ζ = head loss coefficient (adimensional – from diagram 1), v = nominal speed (m/s), g = gravity acceleration 9,81 (m/s²)

After it's possible determinate the flow rate Q (m³/h) in this way:

$$Q = K_v \sqrt{\frac{\Delta h}{10.2}}$$

with K_v = flow rate coefficient (from diagram 2). It correspond to the flow rate in m³/h at 20°C that will cause a pressure drop of 1 m of column of water (10,2 corrective factor in meters).

Cavitation

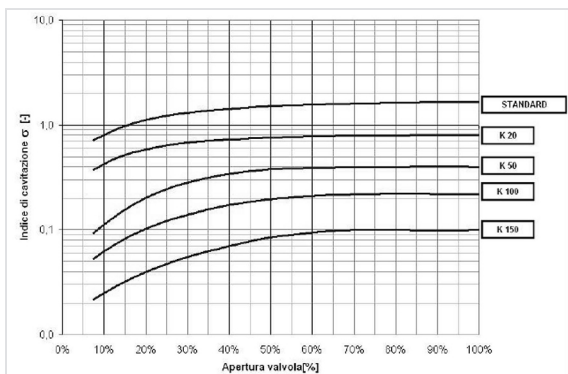

To estimate the risk of cavitation it's possible to use the following diagram. In order to verify if the valve are working in cavitation condition it is necessary to determinate the cavitation index σ by means the following formula:

with: P_{out} = dynamic outlet pressure (m.c.a.), P_{in} = dynamic inlet pressure (m.c.a.), P_a = absolute pressure (~ 10m)

The following diagram shows the critical cavitation index in relation to grade of opening for each typology (standard, anti-cavitation cylinder K20, K50, K100, K150). The value of cavitation index σ should be about 25% above to the critical ones. The opening degree is calculated as showed in Par.4.1.

Marking

On the body according to EN19:

- Nominal diameter in mm (DN)
- Nominal pressure in bar (PN)
- Type of ductile iron
- Manufacturer's logo
- Flow direction

- Model code
- Fusion date.

On the label according to EN19:

- Nominal diameter in mm (DN)
- Nominal pressure in bar (PN)
- Maximum allowable pressure (PFA)
- Closing direction
- Product code
- Ordination number and confirmation
- Manufacturer's logo.

Instruction for use

Storage

The needle valve will have to be held (if possible) in covered places, the most possible protected from the sun (maximum temperature 70°C) and from the rain and generally from the atmospheric agents. Moreover it will have to be avoided that the seal of the same air valves come to contact with powder or earth.

Installation

Had to be respected the direction of flow rate marked in fusion on the body of valve. Reverse flow can be accepted only with complete open valve without any necessity of regulation. It's better to insert a dismounting joint to facilitate all the operation of installation and maintenance. For detailed information see Operation and Maintenance Manual.

Maintenance

Any maintenance operation requested had to be made only when the system has been emptied completely, in order to avoid any accident for the responsible operator. In order to keep this particularity, it is however necessary to operate the valve at least once a year, for a total cycle (opening/closing). For detailed information see Operation and Maintenance Manual.

Note

Saint-Gobain PAM reserves the right to modify the products anyway fully respecting the laws in force. Always use products fully complying with the European Directives to which the products themselves have to comply with.

FOR ANY FURTHER POSSIBLE TECHNICAL INFORMATION, PLEASE CONSULT SAINT-GOBAIN PAM.

Linked products



Operation and
maintenance instructions
for needle valve

The information on this sketch is, to the best of our knowledge correct at the time of printing. However Saint-Gobain are constantly looking at ways of improving their products and services therefore reserve the right to change without prior notice, any of the data shown. Any orders placed will be subject to our Standard Conditions of Sale, available on request.