

Automatic control valves E3000 series with reduced bore

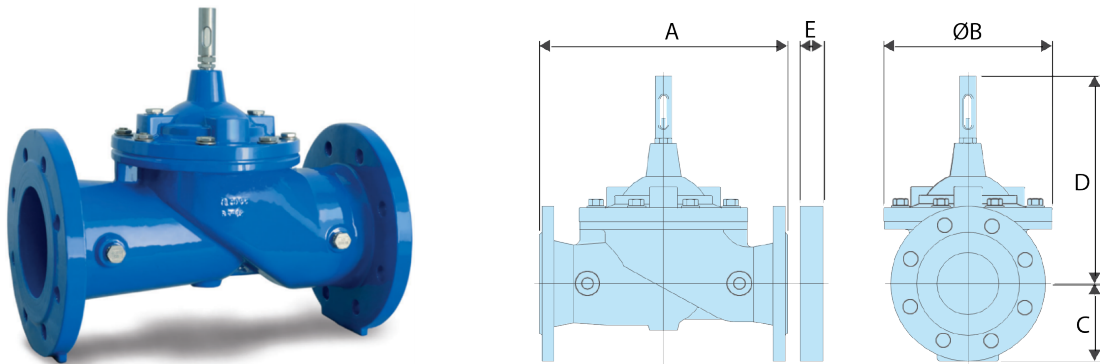

The E3000 series of automatic reduced bore valves is based on a PN 25 globe valve design, made entirely of spheroidal cast iron with stainless steel internal components. This diaphragm valve, equipped with circuits, pilots and other accessories that vary depending on the function, is used in a wide range of applications including pressure reduction, overflow, support, flow control, level control and more.

The main applications are:

- Supply pipelines.
- Distribution networks.
- Buildings.
- Industrial plants.

Construction features and advantages:

- Globe valve with spheroidal cast iron body, class PN 25 bar. Tested in accordance with EN 1074.
- The flange holes, in accordance with standard EN 1092/2, are selected based on the operating pressures.
- The internal profile has been designed to reduce pressure drops as well as vibrations and noise during operation.
- Double chamber version available.
- Polyamide or neoprene diaphragm with nylon reinforcement.
- Stainless steel internal components; spheroidal cast iron plug for larger diameters.
- Different versions of the seat and seal holder, which can also be replaced in already installed valves, to allow excellent cavitation resistance and stability in low flow conditions.
- Maintenance can be easily carried out from above, without removing the valve from the pipeline.
- Large expansion chamber to reduce the risk of cavitation even in the presence of high pressure differentials.

Dimensions and weights:

DN	A	B	C	D	E	Weight
(mm)	(mm)	(mm)	(mm)	(mm)	(mm)	(kg)
40	230	162	83	235	30	18
50	230	162	83	235	30	18
65	290	194	93	275	30	23.5
80	310	218	100	295	30	28
100	350	260	118	335	30	39
150	480	370	150	450	30	84
200	600	444	180	495	30	138
250	730	570	213	600	40	264
300	850	676	242	720	40	405
400	1100	870	310	915	40	704
600	1450	1230	433	1080*	40	2250

The dimension E in the picture above refers only to applications where it is necessary to add a flanged orifice downstream or upstream of the valve, for example for flow control or cavitation prevention.

*: Height without position indicator

Construction features

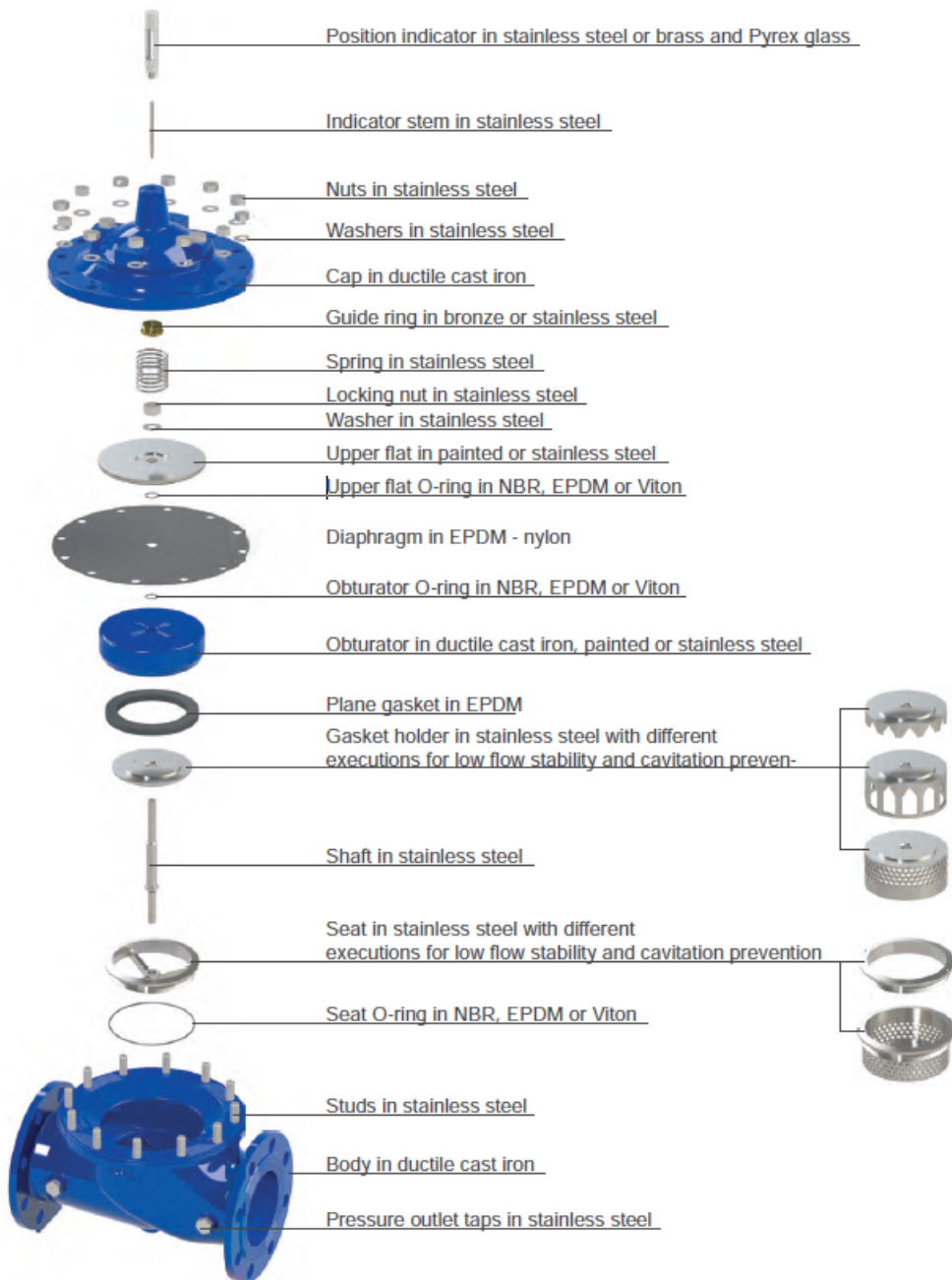

The moving block includes a plug, upper plate, diaphragm, shaft and gasket holder, the latter available in various versions to ensure optimal operation under different flow and pressure conditions, based on design requirements and the results of sizing calculations.

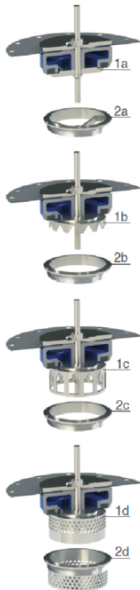

Standard version of the gasket holder and seal seat

The standard version has two guide points, at the bonnet and the seat, which allow the moving block to move without friction. The edge of the gasket holder (1a) is rounded to reduce the risk of oscillation when the valve is almost closed.

BP version for stability at low flow rates

The LOW FLOW system, with a gasket holder (1b) that allows progressive opening, guarantees stability even with extremely low flow rates. When the movable block rises, the valve opens completely, ensuring minimal pressure loss thanks to the design of the body.

V-PORT version for low flow rates and cavitation resistance

The V-PORT system features a progressive opening device (1c) to ensure high stability in low flow conditions, good resistance to cavitation, and improved guidance of the movable block.

ANTICAVITATION version for maximum cavitation resistance

The ANTICAVITATION system, designed for maximum resistance to cavitation, features a double stage (1d, 2d) of energy dissipation through holes whose DN and number vary depending on the applications and performance required.

Valve opening diagram / Kv

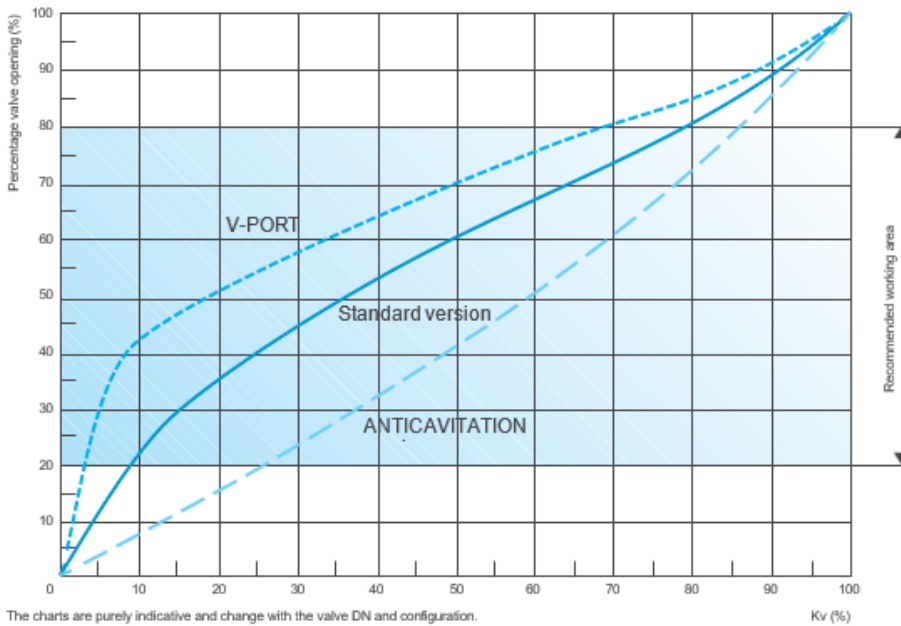

The following graph shows the Kv of the E3000 valves in the standard and anti-cavitation versions in relation to the shutter stroke (both values are expressed as a percentage). We recommend sizing the models so as to limit the variation in opening during operation between 20% and 80%.

Operating principle - On-off mode

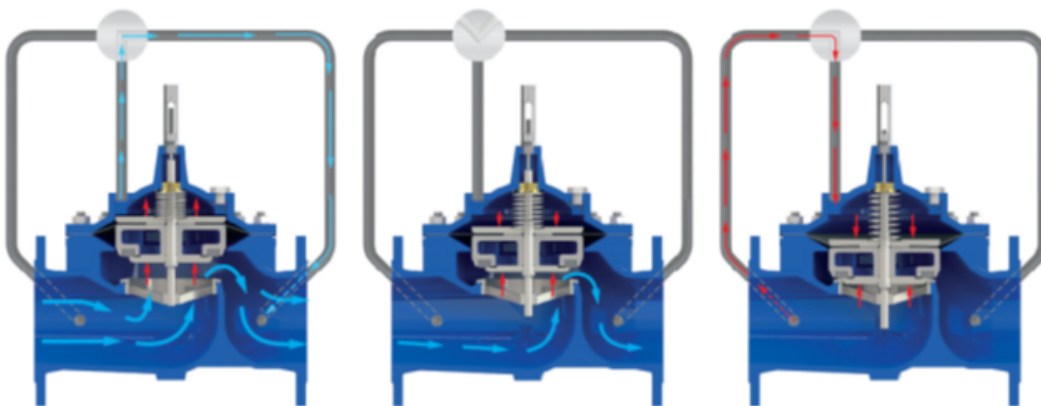

Valve opening	Modulating valve	Valve closure
If the control chamber is connected to the downstream port, the upstream pressure acts on the shutter, pushing it upwards, thus causing the valve to open completely.	If, during operation, the control chamber is completely isolated, the movable block of the valve maintains its position, generating a pressure drop corresponding to the degree of opening.	If the control chamber is connected to the upstream pressure, the valve closes completely due to the difference in surface area between the larger upper plate and the shutter.

Operating principle - On-off mode

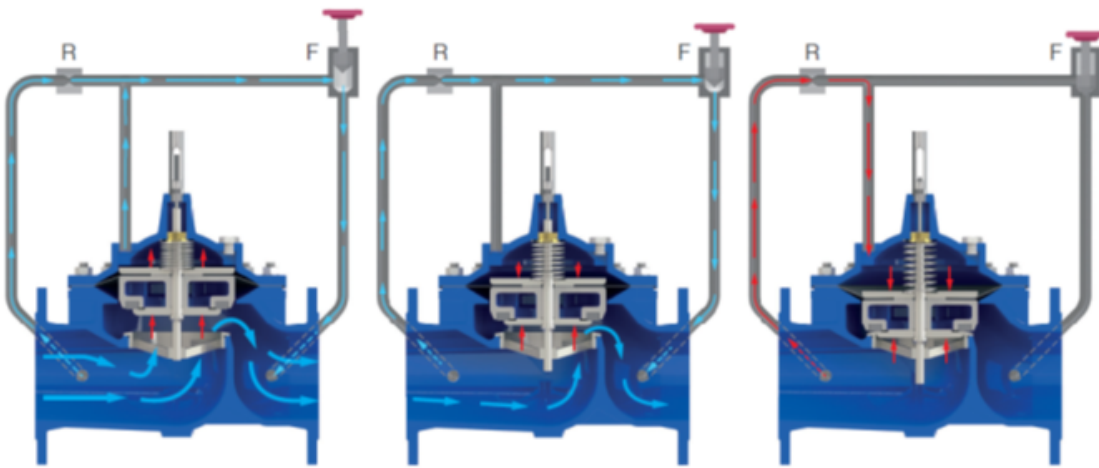

Valve opening	Modulating valve	Valve closure
When the valve is set to modulate, a pressure drop (R) is required between the upstream circuit inlet and the control chamber, as well as a modulating device (F). If the latter is fully open, the pressure inside the control chamber is reduced, causing the main valve to open completely.	If the modulation device (F) is activated, reducing the flow through it, the pressure inside the control chamber increases, pushing down the movable block of the valve.	If the modulating device (F) is fully closed, the pressure in the control chamber reaches that upstream. The movable block then lowers completely, interrupting the flow through the valve.

Operating principle - On-off mode



The regulation and control unit has been designed to include all the components necessary for proper operation of the automatic valves. Compared to other solutions available on the market, its compact structure, it makes the valve circuit easy to maintain and offers the user a wide range of adjustments, allowing various parameters to be set. It is made entirely of stainless steel machined from solid.

The unit consists of:

- a fine mesh filter in AISI 316 to protect the circuit from possible impurities;
- three needle valves for adjusting the reaction speed, opening, and closing of the valve, independently of each other;
- two 1/8 G pressure taps for accessory functions, one filtered and the other unfiltered.

Operating principle - On-off mode

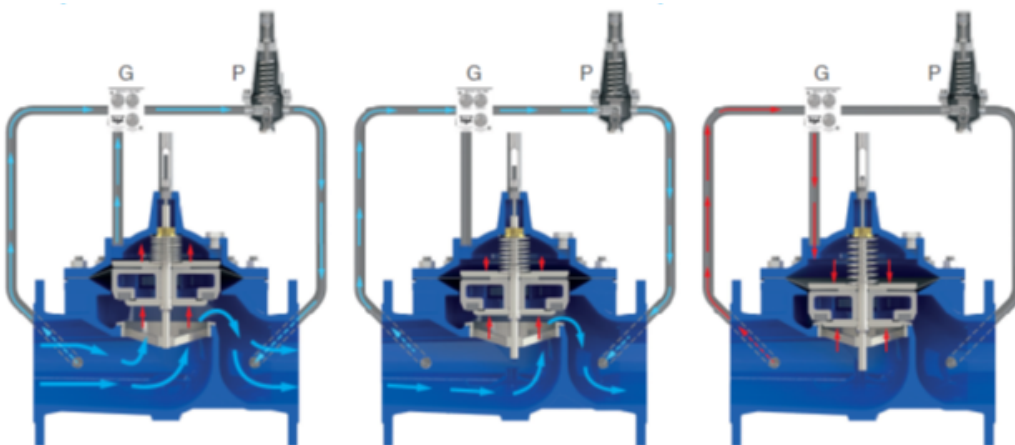

Valve opening	Modulating valve	Valve closure
If the downstream pressure is lower than the pilot pressure (P), the pilot opens, releasing pressure from the control chamber and causing the valve to open.	In response to variations in downstream and upstream pressures, the pilot (P), by modulating, causes the mobile block to move, which determines the pressure drop across the valve, so as to maintain a constant downstream pressure.	If the downstream pressure is higher than the set pressure, the pilot (P) closes; all the upstream pressure then acts on the valve control chamber, causing it to close.

E3000 Standard Version

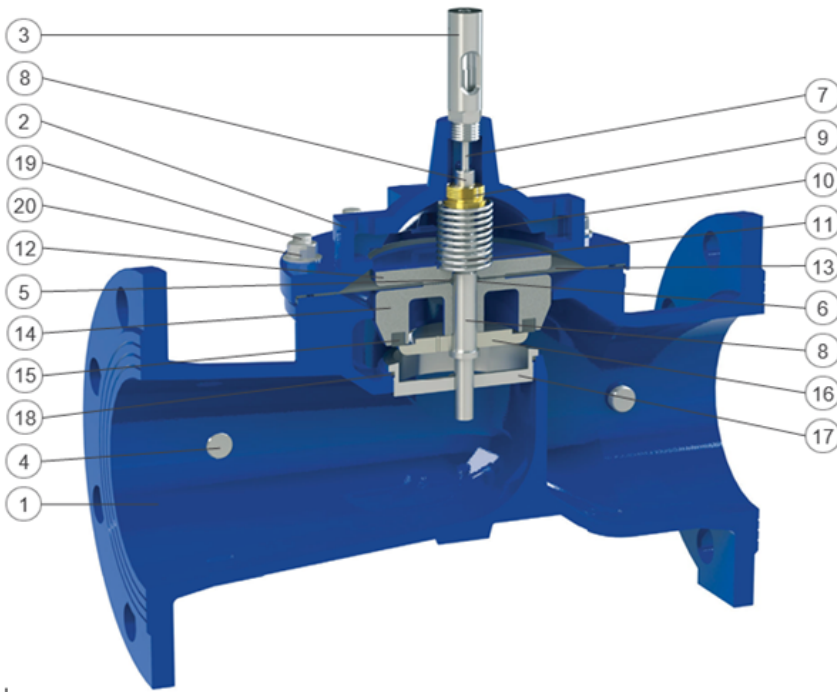

DN1200

Item	Component	Standard Material	Optional
1	Body	Spheroidal cast iron GJS 450-10	
2	Cap	Spheroidal graphite cast iron GJS 450-10	
3	Position indicator	AISI 303 stainless steel	
4	Pressure tab caps	AISI 316 stainless steel	
5	Upper plate O-ring	NBR	EPDM/Viton
6	Shutter O-ring	NBR	EPDM/Viton
7	Indicator rod	AISI 303 stainless steel	AISI 316 stainless steel
8	Guide shaft	AISI 303 stainless steel	AISI 316 stainless steel

Last Update 01/07/2026
 Visit website for latest version



Item	Component	Standard Material	Optional
9	Guide bushing	CuSn5Zn5Pb5 bronze	AISI 303/316 stainless steel
10	Spring	AISI 302 stainless steel	
11	Clamping nut	AISI 304 stainless steel	AISI 316 stainless steel
12	Upper plate	Painted steel Fe 37	AISI 304/316 stainless steel
13	Membrane	EPDM-Nylon	Neoprene
14	Shutter	Painted steel (DN80-150) / Spheroidal cast iron (DN>200)	AISI 304/316 stainless steel
15	Flat gasket	EPDM	NBR
16	Counter seat	AISI 303 stainless steel (AISI 304 from DN 200)	AISI 316 stainless steel
17	Seat	AISI 303 stainless steel (AISI 304 from DN 200)	AISI 316 stainless steel
18	Seat seal O-ring	NBR	EPDM/Viton
19	Stud bolts	AISI 303 stainless steel	AISI 316 stainless steel
20	Nuts and washers	AISI 303 stainless steel	AISI 316 stainless steel

Cavitation chart – E3000 Standard version

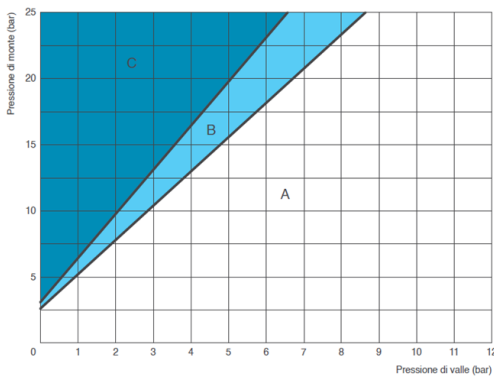

It is important to consider the risk of cavitation, which can cause significant damage, as well as vibrations and noise. On the graph, the point corresponding to the operating condition of the valve, identified by the downstream pressure values (on the x-axis) and upstream pressure values (on the y-axis), falls into one of the three zones identified as follows:

- A: optimal operation;
- B: incipient cavitation;
- C: harmful cavitation.

The graph should be used for valves that modulate with an opening percentage of 35-40%, at standard temperature and at an altitude below 300 m. Under operating conditions, the pressure reduction differential

must not exceed 15 bar.

Sizing table - E3000 Standard version

The following chart shows the recommended flow rate for the proper sizing of E3001 control valves.

DN (mm)			80	100	125	150	200	250	300	400	500	600	800
Flow rate (l/s)	Recommended	Min.	1.1	2.5	3.9	4.1	8.8	16	25	35	63	82	144
		Max.	11	29	43	45	101	180	274	406	695	728	1638
	Pressure relief	Max.	15	38	59	62	132	235	368	530	942	1080	1978

Pressure drop coefficient - E3000 Standard version

The Kv coefficient represents the flow rate that produces a pressure drop of 1 bar when the valve is fully open.

DN (mm)	65	80	100	125	150	200	250	300	400	500	600	700	800	1000
Kv (m ³ /h)	48	54	141	187	198	487	802	1256	1742	3089	3236	7048	7753	11538
Corsa (mm)	15	15	21	27	27	43	56	70	84	110	110	162	162	216

Pressure drop chart- E3000 Standard version

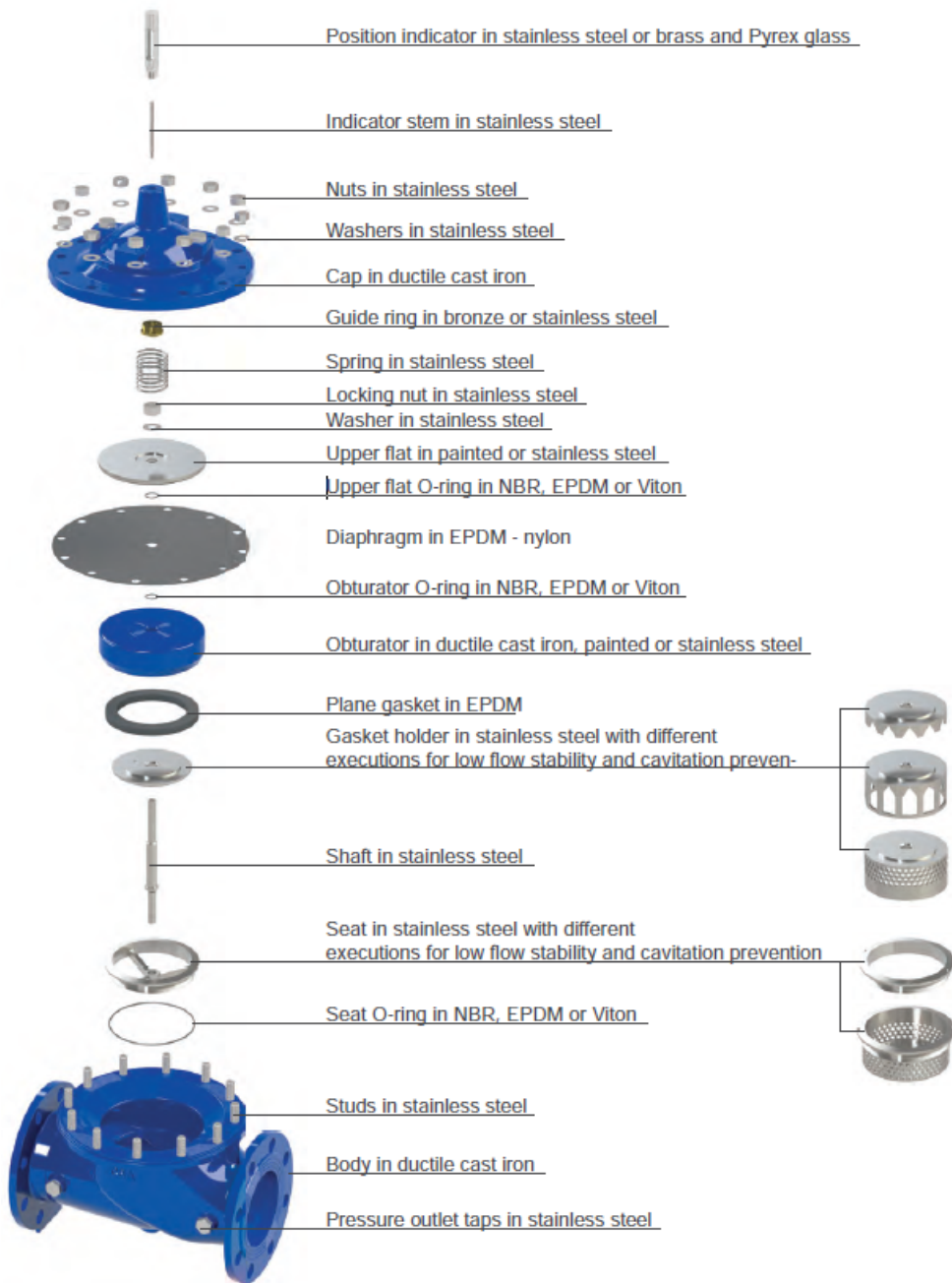

The graph on the side shows the pressure drops of the E3000 automatic control valves in the fully open position as a function of diameter and flow rate expressed in l/s.

E3000 V-port Version

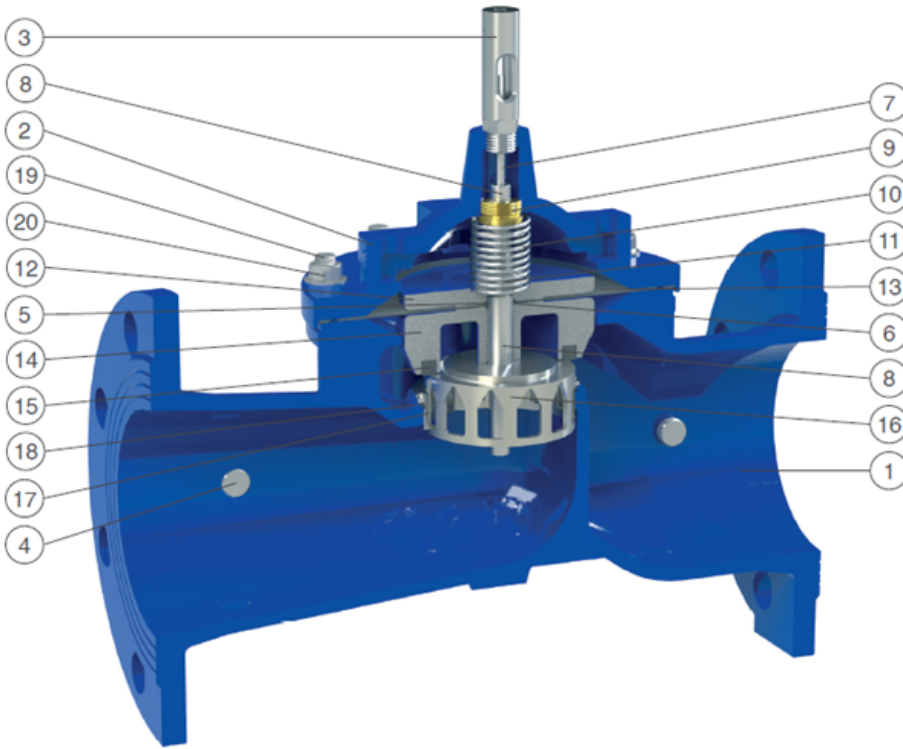

DN1200

Item	Component	Standard Material	Optional
1	Body	Spheroidal cast iron GJS 450-10	
2	Cap	Spheroidal graphite cast iron GJS 450-10	
3	Position indicator	AISI 303 stainless steel	
4	Pressure tab caps	AISI 316 stainless steel	
5	Upper plate O-ring	NBR	EPDM/Viton
6	Shutter O-ring	NBR	EPDM/Viton
7	Indicator rod	AISI 303 stainless steel	AISI 316 stainless steel
8	Guide shaft	AISI 303 stainless steel	AISI 316 stainless steel
9	Guide bushing	CuSn5Zn5Pb5 bronze	AISI 303/316 stainless steel
10	Spring	AISI 302 stainless steel	
11	Clamping nut	AISI 304 stainless steel	AISI 316 stainless steel
12	Upper plate	Painted steel Fe 37	AISI 304/316 stainless steel

Item	Component	Standard Material	Optional
13	Membrane	EPDM-Nylon	Neoprene
14	Shutter	Painted steel (DN80-150) / Spheroidal cast iron (DN>200)	AISI 303/316 stainless steel
15	Flat gasket	EPDM	NBR
16	Counter seat	AISI 303 stainless steel (AISI 304 from DN 200)	AISI 316 stainless steel
17	Seat	AISI 303 stainless steel (AISI 304 from DN 200)	AISI 316 stainless steel
18	Seat seal O-ring	NBR	EPDM/Viton
19	Stud bolts	AISI 304 stainless steel	AISI 316 stainless steel
20	Nuts and washers	AISI 304 stainless steel	AISI 316 stainless steel

Sizing table - E3000 V-port version

The following table shows the recommended flow rates for the correct use of E3000 series automatic valves - V-port version.

DN (mm)			80	100	125	150	200	250	300	400	500	600	800
Flow rate (l/s)	Recommended	Min.	0.5	1.4	2.2	2.3	4.9	8.8	14	20	35	44	71
		Max.	8.8	23	33	35	78	142	211	316	542	582	1325
	Pressure relief	Max.	12	30	46	48	102	185	283	412	734	753	1600

Pressure drop coefficient - E3000 V-port version

The Kv coefficient represents the flow rate that produces a pressure drop of 1 bar when the valve is fully open.

DN (mm)	65	80	100	125	150	200	250	300	400	500	600	700	800	1000
Kv (m ³ /h)	40	43	111	146	154	377	633	967	1356	2409	2588	6343	6977	10429
Corsa (mm)	15	15	21	27	27	43	56	70	84	110	110	162	162	216

Pressure drop chart- E3000 V-port version

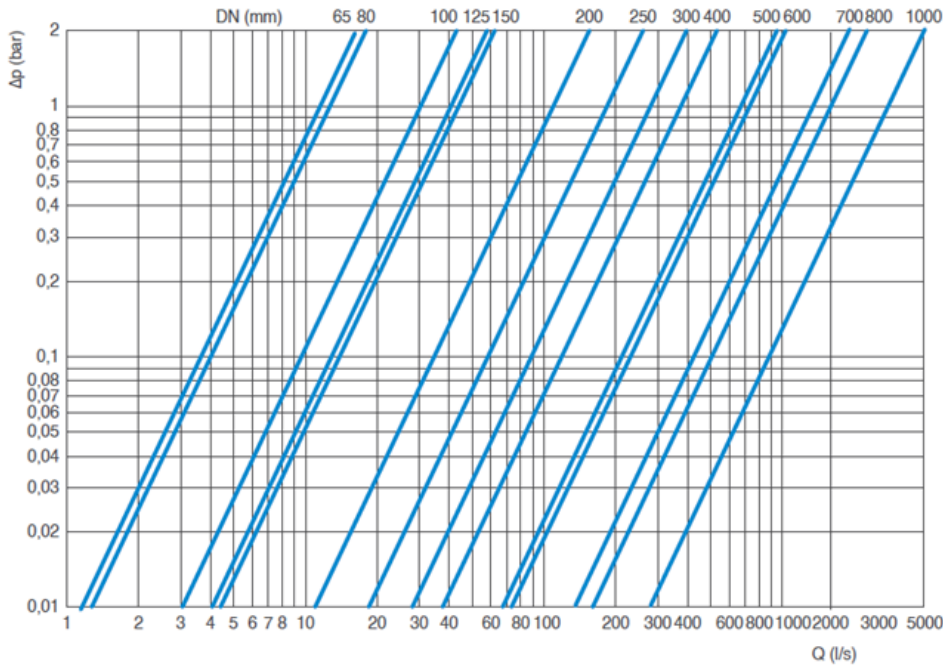

The graph on the side shows the pressure drops of the E3000 automatic control valves in the fully open position as a function of diameter and flow rate expressed in l/s.

E3000 anti-cavitation Version

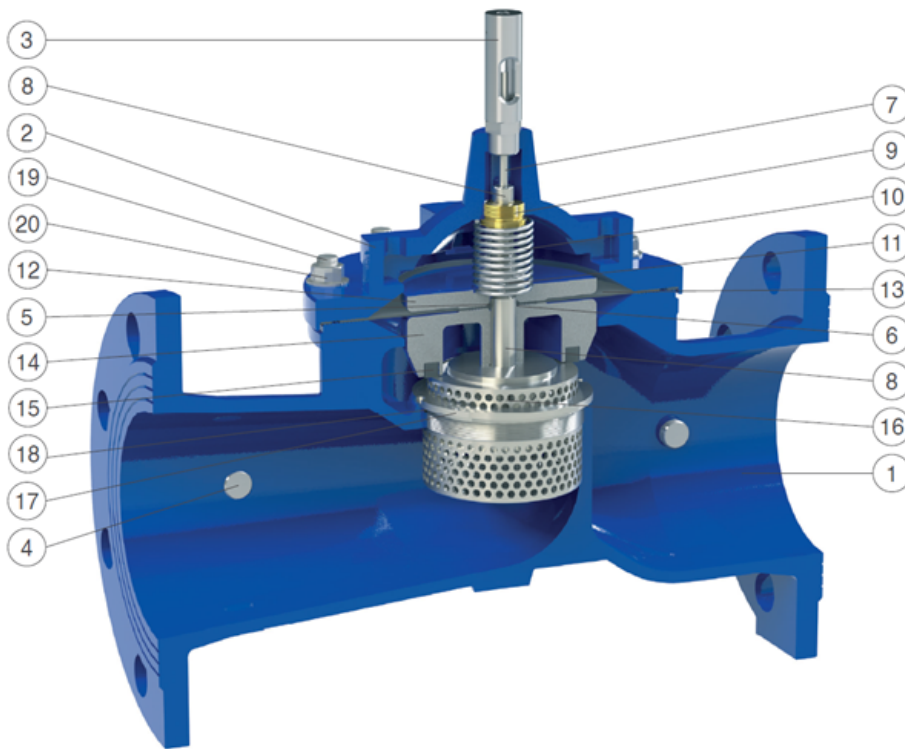

DN1200

Item	Component	Standard Material	Optional
1	Body	Spheroidal cast iron GJS 450-10	
2	Cap	Spheroidal graphite cast iron GJS 450-10	
3	Position indicator	AISI 303 stainless steel	
4	Pressure tab caps	AISI 316 stainless steel	
5	Upper plate O-ring	NBR	EPDM/Viton
6	Shutter O-ring	NBR	EPDM/Viton
7	Indicator rod	AISI 303 stainless steel	AISI 316 stainless steel
8	Guide shaft	AISI 303 stainless steel	AISI 316 stainless steel
9	Guide bushing	CuSn5Zn5Pb5 bronze	AISI 303/316 stainless steel
10	Spring	AISI 302 stainless steel	
11	Clamping nut	AISI 304 stainless steel	AISI 316 stainless steel
12	Upper plate	Painted steel Fe 37	AISI 304/316 stainless steel

Item	Component	Standard Material	Optional
13	Membrane	EPDM-Nylon	Neoprene
14	Shutter	Painted steel (DN80-150) / Spheroidal cast iron (DN>200)	AISI 303/316 stainless steel
15	Flat gasket	EPDM	NBR
16	Counter seat	AISI 303 stainless steel (AISI 304 from DN 200)	AISI 316 stainless steel
17	Seat	AISI 303 stainless steel (AISI 316 from DN 200)	AISI 316 stainless steel
18	Seat seal O-ring	NBR	EPDM/Viton
19	Stud bolts	AISI 304 stainless steel	AISI 316 stainless steel
20	Nuts and washers	AISI 304 stainless steel	AISI 316 stainless steel

Cavitation table – E3000 anti-cavitation version

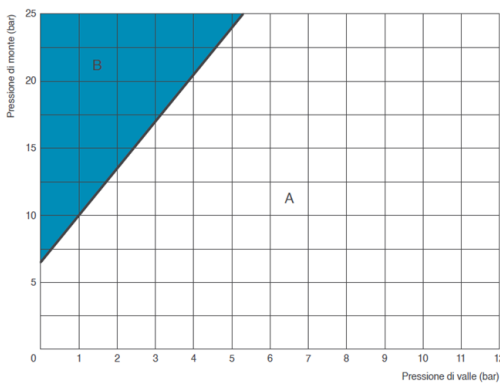

It is important to consider the risk of cavitation, which can cause significant damage, as well as vibrations and noise. On the graph, the point corresponding to the valve’s operating condition, identified by the downstream pressure values (on the x-axis) and upstream pressure values (on the y-axis), falls into one of the three zones identified as follows:

- A: optimal operation;
- B: incipient cavitation;
- C: harmful cavitation.

The graph should be used for valves that modulate with an opening percentage of 35-40%, at standard temperature and at an altitude below 300 m. Under operating conditions, the pressure reduction differential must not exceed 15 bar.

Sizing table – E3000 anti-cavitation version

The following table shows the recommended flow rates for the correct use of E3000 series automatic valves – anti-cavitation version.

DN (mm)			80	100	125	150	200	250	300	400	500	600	800
Flow rate (l/s)	Recommended	Min.	0.7	1.0	2.2	2.3	4.1	6.4	9.2	16	26	37	78
		Max.	5.1	11	16	18	43	75	118	163	289	303	740
	Pressure relief	Max.	11	25	40	42	98	170	267	370	656	688	1083

Pressure drop coefficient - E3000 anti-cavitation version

The Kv coefficient represents the flow rate that produces a pressure drop of 1 bar when the valve is fully open.

DN (mm)	65	80	100	125	150	200	250	300	400	500	600	700	800	1000
Kv (m ³ /h)	21	24	63	72	89	207	361	565	783	1390	1456	2469	2744	5200
Corsa (mm)	15	15	21	27	27	43	56	70	84	110	110	162	162	216

Pressure drop chart- E3000 anti-cavitation version

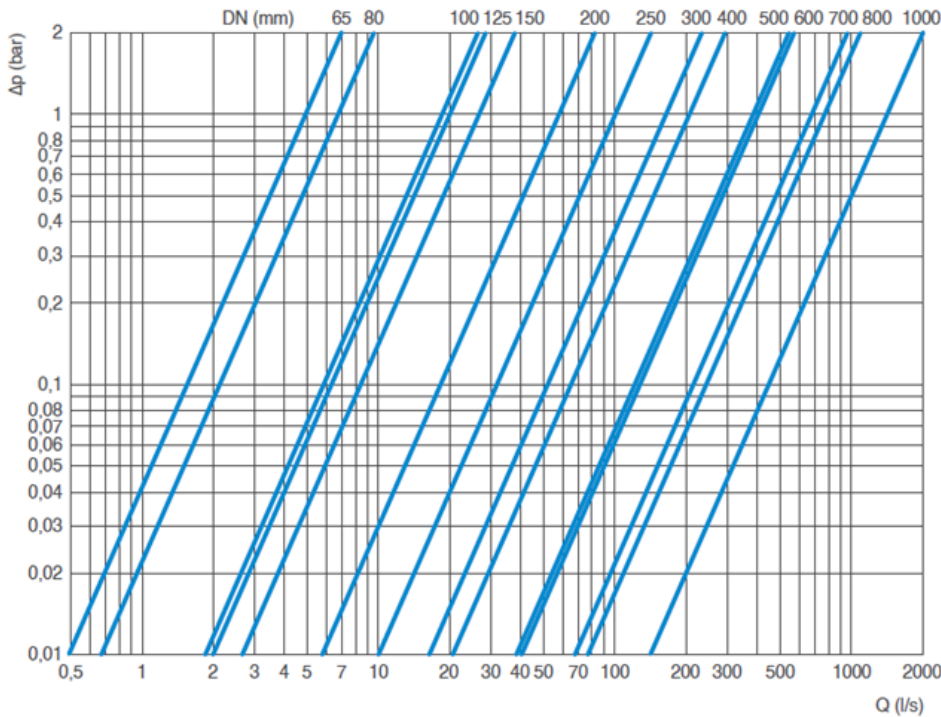

The graph on the side shows the pressure drops of the E3000 automatic control valves in the fully open position as a function of diameter and flow rate expressed in l/s.

The information on this sketch is, to the best of our knowledge correct at the time of printing. However Saint-Gobain are constantly looking at ways of improving their products and services therefore reserve the right to change without prior notice, any of the data shown. Any orders placed will be subject to our Standard Conditions of Sale, available on request.