

Constant Level Control Hydrovalve with Remote Electric Control - E3110-20 / E4110-20



The automatic valve, thanks to the proportional pilot in stainless steel, keeps the tank level constant regardless of the variations in upstream pressure.

A solenoid included in the circuit also allows the valve to open and close in response to impulses sent remotely or from a control unit.

The needle valve allows the adjustment of the valve response time, in order to avoid water hammer phenomena during the closing phase.

The valve is made of stainless steel and ductile iron, and is designed to reduce pressure drops, vibrations and damage due to cavitation.

Flange drilling according to EN 1092/2, different on request.

Certification and testing according to EN 1074

Version	DN (mm)	PN 10		PN 16	
		Mass (kg)	References	Mass (kg)	References
E3110-20	80	25.00	E30A8016P20	25.00	E30A8016P20
E3110-20	100	32.00	E30B1016P20	32.00	E30B1016P20
E3110-20	125	47.00	E30B1216P20	47.00	E30B1216P20
E3110-20	150	54.00	E30B1516P20	54.00	E30B1516P20
E3110-20	200	97.00	E30B2010P20	97.00	E30B2016P20
E3110-20	250	172.00	E30B2510P20	172.00	E30B2516P20

		PN 10		PN 16	
Version	DN (mm)	Mass (kg)	References	Mass (kg)	References
E3110-20	300	287.00	E30B3010P20	287.00	E30B3016P20
E3110-20	400	496.00	E30B4010P20	496.00	E30B4016P20
E3110-20	500	862.00	E30B5010P20	862.00	E30B5016P20
E3110-20	600	1002.00	E30B6010P20	1002.00	E30B6016P20

		PN 10		PN 16	
Version	DN (mm)	Mass (kg)	References	Mass (kg)	References
E4110-20	40/50	19.00	E40A5016P20	19.00	E40A5016P20
E4110-20	65	21.00	E40A6516P20	21.00	E40A6516P20
E4110-20	80	26.00	E40A8016P20	26.00	E40A8016P20
E4110-20	100	39.00	E40B1016P20	39.00	E40B1016P20
E4110-20	150	84.00	E40B1516P20	84.00	E40B1516P20
E4110-20	200	138.00	E40B2010P20	138.00	E40B2016P20
E4110-20	250	247.00	E40B2510P20	247.00	E40B2516P20
E4110-20	300	784.00	E40B3010P20	421.00	E40B3016P20
E4110-20	400	784.00	E40B4010P20	784.00	E40B4016P20
E4110-20	600	2250.00	E40B6010P20	2250.00	E40B6016P20

Applications

- For break-section tanks and gravity lines when proportional level control and an electronic safety system to prevent excess flow are required.
- For the control of tanks for civil and industrial use, and where it is necessary to maintain a constant level with continuous modulation, together with the possibility of closing/opening in response to control or alarm signals.

Accessories

- Open-close indicator.
- Manometers.
- Self-cleaning high capacity filter.
- System to ensure greater resistance to cavitation and accurate regulation in case of low flow rates.
- Limiter of opening manual.

Directions for use

- Avoid high points and changes in slope in the tube connecting the valve to the pilot to prevent the formation of air pockets.
- For correct operation, a minimum pressure of 0.6 bar is required on the pilot. In case of lower values, consider using a low flow support pilot and the manual opening limiter

Optional configurations

- Constant level control valve with solenoid control and anti-return system.
- Constant level control valve with solenoid control and quick relief pilot.

Operating conditions

- Fluid: treated water.
- Minimum pressure: 0,6 bar.
- Maximum pressure: 16 bar.
- Recommended operating pressure: 6 bar. Higher on request.
- Maximum temperature: 70 °C.

Constant level pilot adjustment

- Standard stroke 85 mm, different on request.

Solenoid valve data

- Voltage: 24 V DC, 24 V/50 Hz, 230 V/50 Hz. Other voltage on request.
- Consumption electrical: inrush AC (VA) 24, hold AC (VA) 17 (8 W), DC hot/ cold coil 8/9 W.

How it works

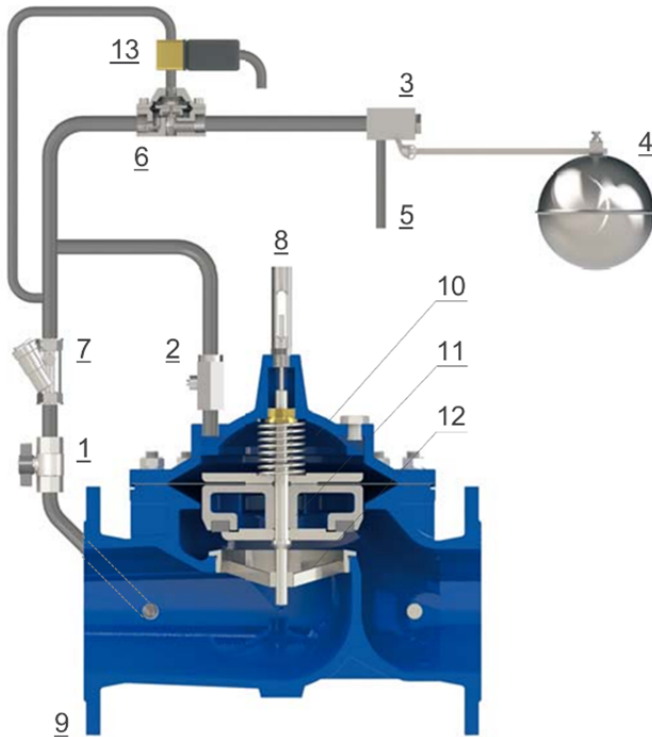

The hydraulic valve is regulated by a two-way proportional level control pilot (3), connected to the valve by a tube with an internal diameter of at least 9 mm, which is not supplied.

When the tank level drops, the pilot (3) opens, discharging pressure from the valve chamber (10); the consequent rise of the shutter (11) allows a flow through the seat (12) proportional to consumption.

If, however, the tank level rises, the pilot (3) modulates to close; by reducing the discharge to the atmosphere (5), the pressure in the chamber (10) increases, with consequent descent of the shutter (11) towards the seat (12), and a decrease in flow through the valve.

The solenoid (13) can also interrupt the passage through the flow accelerator (6) by closing the valve, in response to impulses received from a programmer or sent remotely.

A fixed orifice is inserted in the filter (7) necessary for the operation of the circuit, while the needle valve (2) regulates the flow in and out of the chamber, to prevent pressure surges during closing.

Installation diagram



The hydraulic valve is connected to the pilot (2) by a single pipe and controlled by a control unit or remotely.

Shut-off devices (1) are required to allow maintenance and an upstream filter (3).

The pilot (2) must always be placed in a position protected from turbulence caused by the flow feeding the tank.

In case of static pressure higher than 6 bar, an anti-cavitation system and a direct-acting pressure reducer are recommended.

The information on this sketch is, to the best of our knowledge correct at the time of printing. However Saint-Gobain are constantly looking at ways of improving their products and services therefore reserve the right to change without prior notice, any of the data shown. Any orders placed will be subject to our Standard Conditions of Sale, available on request.