

Upstream Pressure Support Valve - E3116-00 / E4116-00



E3116-00 / E4116-00 hydraulically operated automatic valve sustains the upstream pressure by stabilizing it at a set and adjustable value, regardless of flow rate variations.

Equipped with a visual position indicator in the standard version and made entirely of stainless steel and coated ductile iron with epoxy paint using FBT (fluid bed technology) technique, the valve has been designed to reduce pressure drops, vibrations and cavitation damage. The E3116-00 / E4116-00 can be used for a wide range of applications.

		PN 10		PN 16	
DN (mm)	Version	Mass (kg)	References	Mass (kg)	References
80	E3116-00	26.00	E36A8016P00	26.00	E36A8016P00
100	E3116-00	32.00	E36B1016P00	32.00	E36B1016P00
125	E3116-00	48.00	E36B1216P00	48.00	E36B1216P00
150	E3116-00	55.00	E36B1516P00	55.00	E36B1516P00
200	E3116-00	97.00	E36B2010P00	97.00	E36B2016P00
250	E3116-00	172.00	E36B2510P00	172.00	E36B2516P00
300	E3116-00	288.00	E36B3010P00	288.00	E36B3016P00
400	E3116-00	496.00	E36B4010P00	496.00	E36B4016P00
500	E3116-00	862.00	E36B5010P00	862.00	E36B5016P00
600	E3116-00	1002.00	E36B6010P00	1002.00	E36B6016P00

		PN 10		PN 16	
DN (mm)	Version	Mass (kg)	References	Mass (kg)	References
40/50	E4116-00	20.00	E46A5016P00	20.00	E46A5016P00

DN (mm)	Version	PN 10		PN 16	
		Mass (kg)	References	Mass (kg)	References
65	E4116-00	21.00	E46A6516P00	21.00	E46A6516P00
80	E4116-00	26.00	E46A8016P00	26.00	E46A8016P00
100	E4116-00	40.00	E46B1016P00	40.00	E46B1016P00
150	E4116-00	84.00	E46B1516P00	84.00	E46B1516P00
200	E4116-00	138.00	E46B2010P00	138.00	E46B2016P00
250	E4116-00	248.00	E46B2510P00	248.00	E46B2516P00
300	E4116-00	421.00	E46B3010P00	421.00	E46B3016P00
400	E4116-00	784.00	E46B4010P00	784.00	E46B4016P00
600	E4116-00	2250.00	E46B6010P00	2250.00	E46B6016P00

Applications

- On branches of the main pipeline to reduce pressure in secondary lines.
- On the tank supply lines to regulate pressure and flow rate according to the values required for level control.
- In gravity pipes to ensure minimum pressure to users located in the highest areas, in case of high consumption in the lowest areas.

Accessories

- The position indicator with 4-20 mA output.
- The open-close indicator.
- Manometers.
- Self-cleaning high capacity filter.

Notes to the designer

- Inlet and outlet pressure, flow rate and application are required for cavitation sizing and analysis.
- Recommended flow rates and working conditions are given in the E3000 - E4000 valve catalogue.
- It is recommended to leave a straight section of pipe 3 nominal diameters long upstream of the valve.

Optional configurations

- Upstream pressure sustaining valve with anti-reflux system.
- Sustaining valve with solenoid control valve.
- Sustaining valve with high sensitivity pilot.

Operating conditions

- Fluid: treated water.

- Minimum pressure: 0,7 bar.
- Maximum pressure: 25 bar. Higher on request.
- Maximum temperature: 70 °C.

Pilot support adjustment field

- Blue spring: 0.7 to 7 bar.
- Red spring: 1.5 to 15 bar.
- Higher values up to 25 bar on request
- Values lower than 0.7 bar available with high sensitivity pilots.

How it works

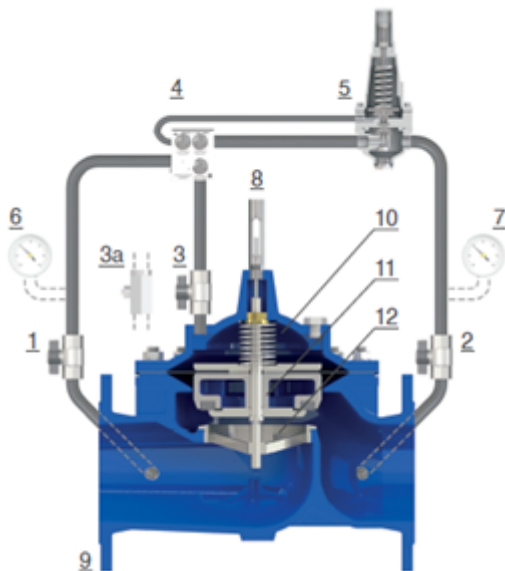

The valve is controlled by a high capacity two-way pilot (5) with adjustable calibration which, through the regulation unit (4), receives the upstream pressure value.

If the latter exceeds the calibration value, the pilot opens, discharging pressure from the control chamber (10) with consequent rise of the shutter (11) and flow through the seat (12) to protect the system.

When the upstream pressure drops below the set threshold, the pilot modulates the flow in the circuit, so the pressure in the valve chamber increases, bringing the shutter to the closed position, which stops the flow through the main valve.

The pressure at the inlet and outlet of the main chamber (10) is controlled by the unique regulation unit (4), equipped with a filter and three adjustable needle valves, necessary to ensure stability and make the opening and closing speeds of the valve independent of each other.

Installation diagram

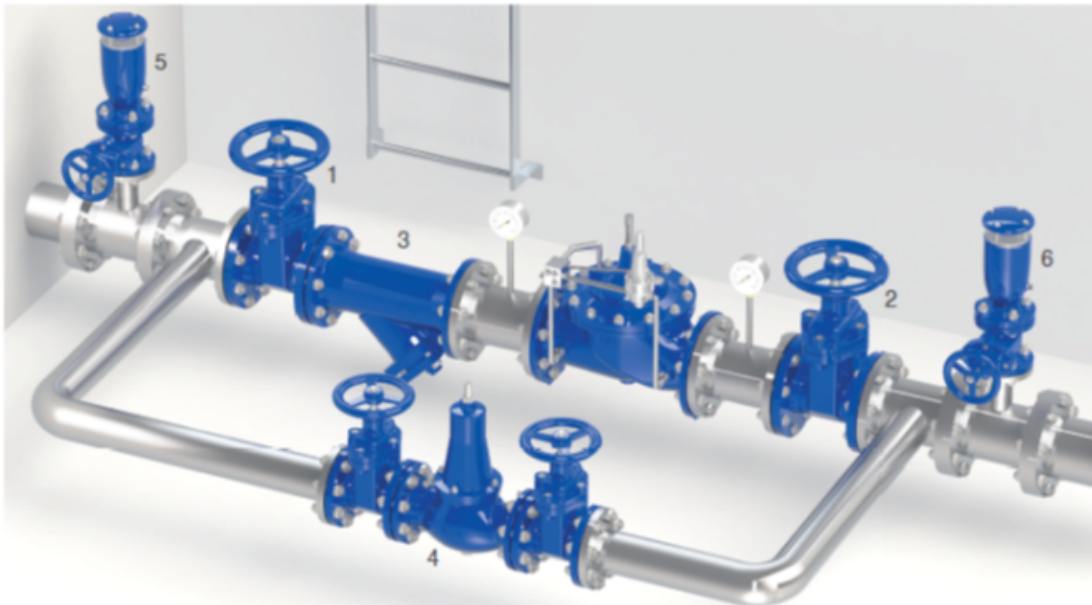

The recommended installation scheme of the E3116-00 / E4116-00 valve, used for pressure sustaining, includes shut-off devices (1, 2) and bypass to allow maintenance, and a filter (3), which retains any impurities.

The direct-acting sustaining valve DRV-S (4), reliable even after long periods of inactivity, represents the best solution for the bypass, usually not in operation.

The insertion of combined anti-water hammer vents FBA (5, 6) upstream and downstream is also recommended.

The information on this sketch is, to the best of our knowledge correct at the time of printing. However Saint-Gobain are constantly looking at ways of improving their products and services therefore reserve the right to change without prior notice, any of the data shown. Any orders placed will be subject to our Standard Conditions of Sale, available on request.