

## Kit Basic valve – Position indicator system

DN	Mass	References
DN50, 60/65, 80, 100	0.50 kg	161911
DN125, 150	0.50 kg	166608
DN200	1.00 kg	161929
DN250	2.00 kg	161935
DN300, 350	3.00 kg	161942
DN400	4.00 kg	161948
DN500	5.00 kg	161954
DN600	6.00 kg	161958
DN700	7.00 kg	161963

### Details

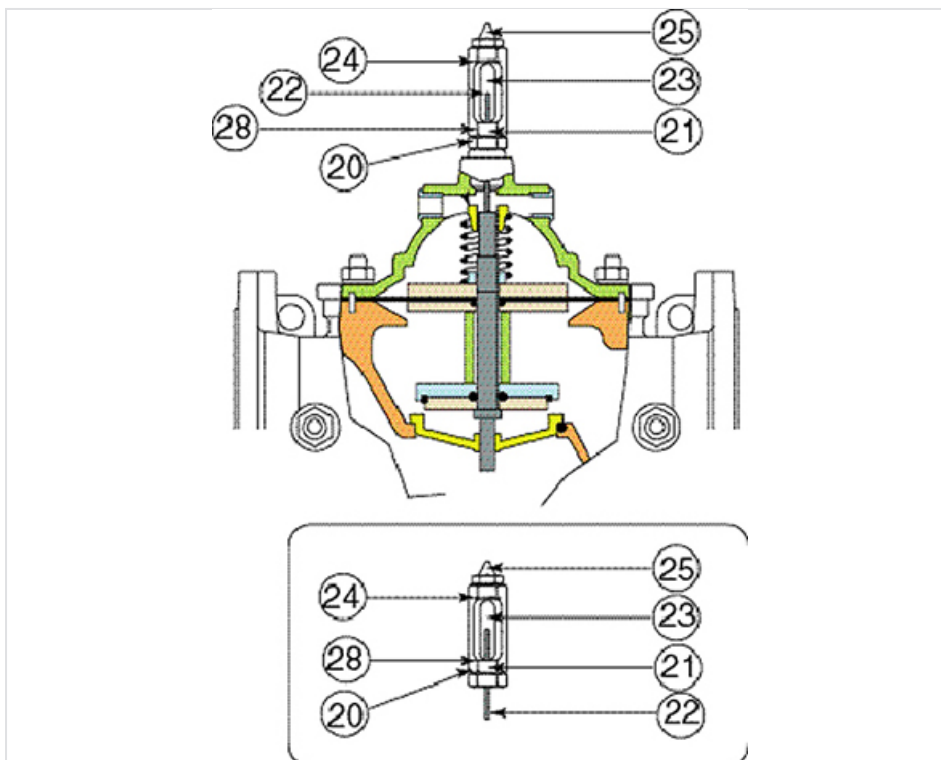

Kit with

- Item 20: 1 base position indicator
- Item 21: 1 body
- Item 22: 1 position indicator stem
- Item 23: 1 screen
- Item 24: 1 O'ring
- Item 25: 1 manual venting cock
- Item 28: 1 O'ring

**Note:** this kit is delivered assembled.

*The information on this sketch is, to the best of our knowledge correct at the time of printing. However Saint-Gobain are constantly looking at ways of improving their products and services therefore reserve the right to change without prior notice, any of the data shown. Any orders placed will be subject to our Standard Conditions of Sale, available on request.*