

Kit Basic valve – Spare part for position indicator

DN	Mass	References
DN50, 60/65, 80,100 125, 150, 200	1.00 kg	161912
DN250, 300, 350		
DN400, 500, 600, 700	3.00 kg	161949

Details

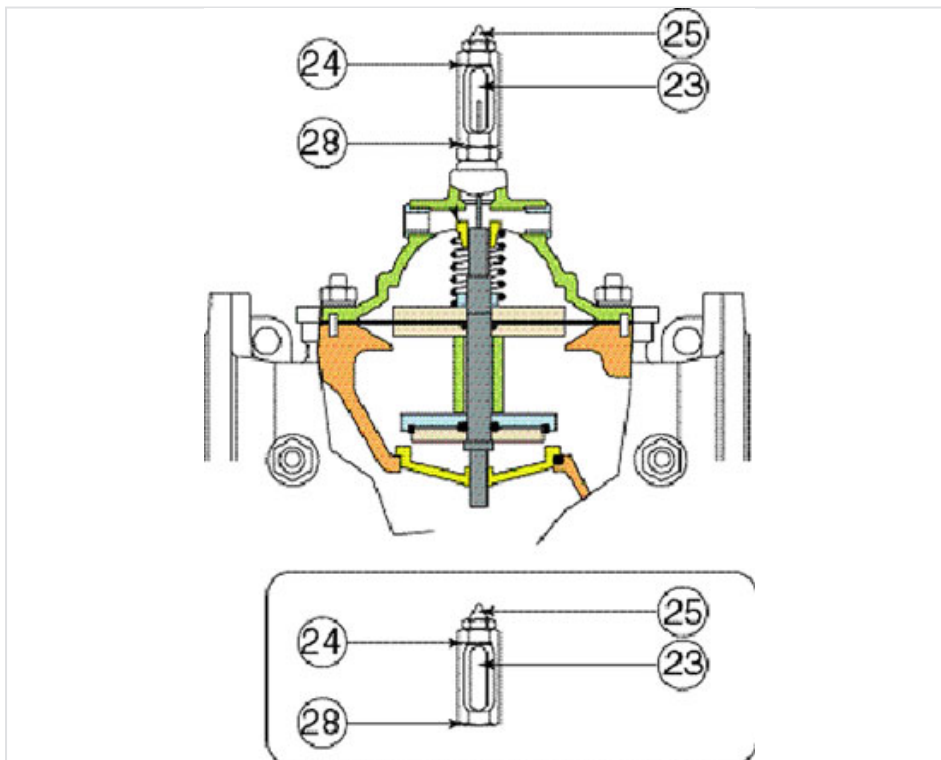

Kit with

- Item 23: 1 screen
- Item 24: 1 O'ring
- Item 25: 1 manual venting cock
- Item 28: 1 O'ring

The information on this sketch is, to the best of our knowledge correct at the time of printing. However Saint-Gobain are constantly looking at ways of improving their products and services therefore reserve the right to change without prior notice, any of the data shown. Any orders placed will be subject to our Standard Conditions of Sale, available on request.