

Flange Spigot ALPINAL with Fixed Flange + Weld bead Ve

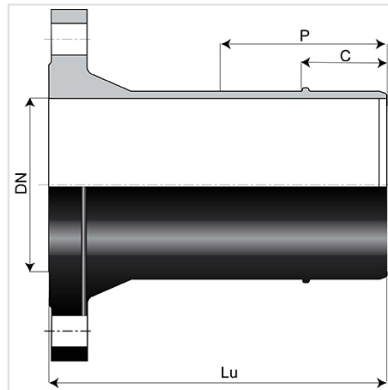

DN	Lu	PN 100		PN 40		PN 63	
		Mass	References	Mass	References	Mass	References
150 mm	380 mm					33.20 kg	AKB15BU5
200 mm	400 mm	40.80 kg	AKB20BUB				
250 mm	420 mm			45.80 kg	AKB25BU4		

Field of use:

- For connecting and water supply of snow guns
- Working networks under very high pressures

Main characteristics:

- Internal lining: cement mortar
- External coating: bituminous paint
- Thickness of ductile iron adapted to the pressure
- Elastomer of quality EPDM
- Class : pressure class according to EN 545 and ISO 2531

Linked products



Flanged joint with hot galvanised steel bolts, nuts and washers for ALPINAL

The information on this sketch is, to the best of our knowledge correct at the time of printing. However Saint-Gobain are constantly looking at ways of improving their products and services therefore reserve the right to change without prior notice, any of the data shown. Any orders placed will be subject to our Standard Conditions of Sale, available on request.