

## ALPINAL All Socket Tee Universal Tyton DN100-300

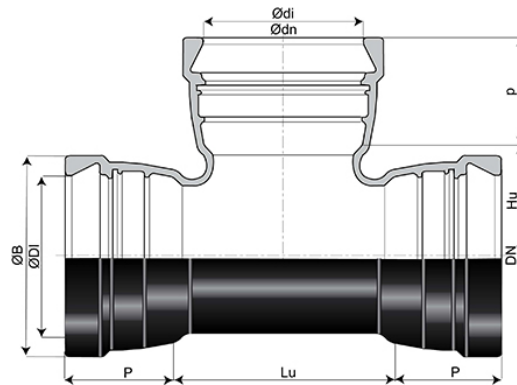

DN	Ø dn	Lu	P	Ø DI	Ø B	Hu	p	Ø di	Mass	References
125 mm	100 mm	195 mm	138.2 mm	146.5 mm	201.4 mm	110 mm	139 mm	120.5 mm	23.50 kg	ANB12TEOF
125 mm	125 mm	225 mm	138.2 mm	146.5 mm	201.4 mm	110 mm	138.2 mm	146.5 mm	30.05 kg	ANB12TEOG
200 mm	150 mm	255 mm	154 mm	224.5 mm	290 mm	150 mm	145.8 mm	172.5 mm	51.00 kg	ANB20TEOJ
250 mm	250 mm	380 mm	165.1 mm	276.5 mm	366.2 mm	190 mm	165.1 mm	276.5 mm	147.00 kg	ANB25TEAL

### Field of use:

- For connecting and water supply of snow guns
- Working networks under very high pressures

### Main characteristics:

- Internal lining: cement mortar
- External coating: bituminous paint
- Thickness of ductile iron adapted to the pressure
- Elastomer of quality EPDM
- Class : pressure class according to EN 545 and ISO 2531

## Linked products

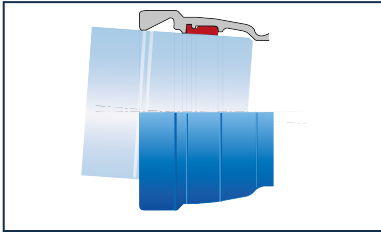

Kit ALPINAL Universal  
Tyton Fitting PCB +  
Universal Tyton Joint

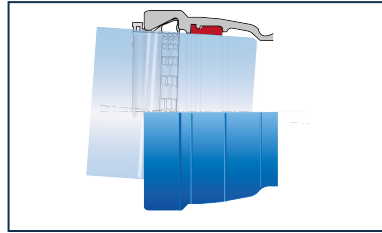

Kit ALPINAL Universal  
Tyton Fitting PCB +  
Universal Tyton Vi Joint

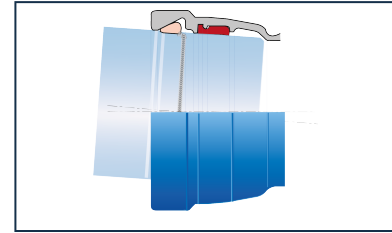

Kit ALPINAL Universal  
Tyton Fitting PCB +  
Universal Tyton Ve Joint

*The information on this sketch is, to the best of our knowledge correct at the time of printing. However Saint-Gobain are constantly looking at ways of improving their products and services therefore reserve the right to change without prior notice, any of the data shown. Any orders placed will be subject to our Standard Conditions of Sale, available on request.*