

Washout Tee (PECB) with 3 Rotatable Flanges

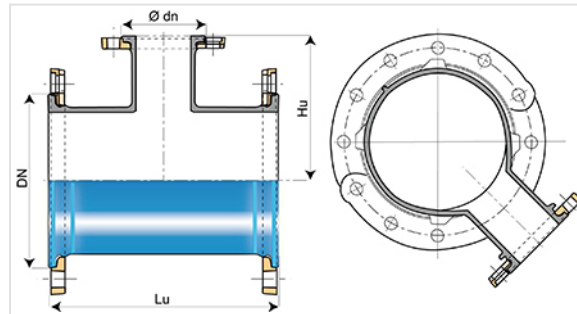

| DN (mm) | Ødn (mm) | Lu (mm) | Hu (mm) | PN 10 | | PN 16 | | PN 25 | |
|---------|----------|---------|---------|-----------|--------------|-----------|--------------|-----------|--------------|
| | | | | Mass (kg) | References | Mass (kg) | References | Mass (kg) | References |
| 250 | 100 | 425 | 270 | 46.90 | BAB25UV1FTT2 | 46.90 | BAB25UV2FTT2 | 53.40 | BAB25UV3FTT2 |
| 300 | 100 | 450 | 300 | 62.50 | BAB30UV1FTT2 | 61.50 | BAB30UV2FTT2 | 70.40 | BAB30UV3FTT2 |
| 350 | 100 | 470 | 330 | 81.06 | BAB35UV1FTT2 | 83.37 | BAB35UV2FTT2 | 96.50 | BAB35UV3FTT2 |
| 400 | 100 | 490 | 360 | 104.90 | BAB40UV1FTT2 | 114.35 | BAB40UV2FTT2 | 134.61 | BAB40UV3FTT2 |
| 450 | 100 | 515 | 390 | 119.49 | BAB45UV1FTT2 | 129.57 | BAB45UV2FTT2 | | |
| 500 | 100 | 535 | 420 | 144.27 | BAB50UV1FTT2 | 171.57 | BAB50UV2FTT2 | 185.54 | BAB50UV3FTT2 |
| 600 | 200 | 700 | 500 | 223.02 | BAB60UV1KTT2 | 275.73 | BAB60UV2KTT2 | 283.40 | BAB60UV3KTT2 |

Field of use:

- For drinking water networks

Main characteristics:

- External and internal coating : Blue epoxy powder 250 microns average thickness with a minimum of 200 microns, conforming to EN 14901 (PECB)
- In conformity with EN 545:2010 and ISO 2531:2009

Linked products

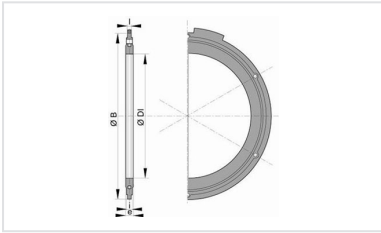

Flanged joint with hot galvanized steel bolts, nuts and washers

The information on this sketch is, to the best of our knowledge correct at the time of printing. However Saint-Gobain are constantly looking at ways of improving their products and services therefore reserve the right to change without prior notice, any of the data shown. Any orders placed will be subject to our Standard Conditions of Sale, available on request.